



Global Trends: Visions, Opportunities and Challenges for a Sustainable Future

Proceedings of the International Conference on Global and Emerging Trends (ICGET)

• 2 – 4 MAY 2018 •

EDITORS:

Bosede I. Edwards	Baba Adams Ndalai
Nyagwarimam O. Ali	Adebanjo Adekiigbe
Olakunle Elijah	Mallam Adamu Babikko
Olagoke A. Oladokun	Abubakar D. Isah
Hamman T. Gabdo	



Global Trends: Visions, Opportunities and Challenges for a Sustainable Future.

Proceedings of the International Conference on Global and Emerging Trends
(ICGET)

2 – 4 May 2018

Editors:

Bosede Iyiade Edwards, Ph.D
*Imagineering Institute
Iskandar Puteri, Johor. Malaysia*

Nyagwarimam O. Ali, Ph.D
Universiti Teknologi Malaysia, Johor. Malaysia

Olagoke A. Oladokun, Ph.D
*University of Maiduguri
Borno, Nigeria*

Olakunle Elijah, Ph.D
Universiti Teknologi Malaysia, Johor. Malaysia

Mallam Adamu Babikkoi, Ph.D
*Federal College of Education
Yola. Nigeria*

Baba Adams Ndalai, Ph.D
*Federal Polytechnic, Idah
Benue. Nigeria*

Adebanjo Adekiigbe, Ph.D
*Federal Polytechnic, Ede
Osun. Nigeria*

Abubakar Danladi Isah
*Federal University of Technology
Minna. Nigeria*

Hamman Tukur Gabdo
*Baze University, Abuja
FCT, Nigeria*

Proceedings of the International Conference on Global and Emerging Trends (ICGET) 2018

Copyright © OT Consulting and Global Trends Academy 2018

ISBN: 978-978-55535-2-9

Authors retain full copyright to their individual works.



In accordance with the Open Access Initiative, articles published in the ICGET 2018 Book of Proceedings are freely available on the public internet. Users can 'read, download, copy, distribute, print, search, or link to the full texts of the articles, crawl them for indexing, pass them as data to software, or use them for any other lawful purpose, without any financial, legal, or technical barriers'. Authors however retain 'full control over the integrity of their work as well as the right to be properly acknowledged and cited'.

Published By:

Global Trends Academy

A Joint Initiative of Arrows Transactions Sdn Bhd and OT Consulting
Malaysia. Nigeria.

Website: www.globaltrendsacademy.com

For All Inquiries:

Email: info@globaltrendsacademy.com; globaltrendsacademy@gmail.com

Phone: (+60)-1121-74-8309

Corporate Office:

S44-B-01-12, UTMTEC

Universiti Teknologi Malaysia

Johor Bahru 81310. Johor. Malaysia

FOREWORD

Dear Authors and Esteemed Readers,

It is with deep fulfilment that I write this foreword to the maiden edition of the Proceedings of the International Conference on Global and Emerging Trends (ICGET) 2018, held at Abuja, Nigeria with sessions held in parallel at Johor Bahru, Malaysia on May 2 – 4, 2018. The conference theme is 'Global Trends: Visions, Opportunities & Challenges for a Sustainable Future'. As the maiden event in the series, ICGET 2018 provides a forum for reporting the latest developments in global and emerging trends from multidisciplinary perspectives. I am pleased to present the proceedings of the conference as its published record.

A total of 83 submissions were received, of which 55 were accepted. 41 were presented in Nigeria, 12 in Malaysia, and 2 online. There were also several non-presenting participants and observers who were present for the sheer purpose of learning. ICGET participants represent 3 continents and 5 countries. The paper submission and reviewing process was managed using the Microsoft Conference Management Tool (CMT), and every paper was reviewed by minimum of two reviewers with Ph.D in the respective field. Though the CMT learning curve was steep for many of the authors and reviewers, it represented a good experience in line with the conference theme. We thank all authors and participants for their contributions and for their patience and willingness to learn. We are most grateful to the external reviewers, for their hard work in the prompt and sound review of submissions. Much appreciation also goes to the secretariat and publication team for their commitment, availability and support for authors and reviewers during the entire process.

There were two invited keynote presentations, a workshop and two plenary sessions addressing issues related to the conference theme. Dr. Mohamed Kasim Abdul Jalil, Associate professor of Mechanical Engineering from Universiti Teknologi Malaysia presented the first keynote on 'Global Trends in Higher Education: Challenges and Opportunities' while Mr. Chet W. Sisk, Futurist and Founder of Lead Global, from Denver, Colorado, spoke on 'Moving from Profit to Abundance: Trends Indicating the Rise of the Ubuntu Economy' in the second keynote. The two keynote addresses presented the conference theme from academic and secular perspectives respectively. There were plenary presentations on 'The future of social interactions and networking' and 'International Development Opportunities for Researchers & Academics'. Together, the various sessions lent exceptionally rich perspectives to the conference theme. The conference program represents the efforts of many people, including the indefatigable members of the local and international organizing committee, to whom gratitude alone is insufficient.

This book of Proceedings will serve as an excellent reference book that will inspire further study and research in the areas covered. ICGET 2018 is the first in the series, and though by no means perfect, it stands out as a noble attempt at something great.

We look forward to the future with you.

Thank you.

The Editors, ICGET 2018

Table of Contents

FOREWORD	<i>iv</i>
<i>Conference Chairs</i>	<i>ix</i>
<i>Program Chairs</i>	<i>ix</i>
<i>Conference Committee</i>	<i>x</i>
<i>Keynote Speakers</i>	<i>xi</i>
<i>List of Reviewers</i>	<i>xii</i>
ARTS AND EDUCATION	1
<i>Using Outdoor Activity to Enhance the Understanding of Science Concepts among Students from Non-Science Background</i>	<i>2</i>
<i>Effects of Implementation of Problem-Based Learning on Students ‘Academic Achievement and Attitudes Towards Learning Chemistry</i>	<i>6</i>
<i>Language Learning Motivation in Global Context: From Integrativeness to the Ideal L2 Self</i>	<i>9</i>
<i>Smart Pedagogy of Learning Technologies: Implementing TPACK in Design and Selection of Technologies for the Future Classroom</i>	<i>13</i>
<i>Key Determinants of Contraceptive Use Among Married Women in North-Eastern Region of Nigeria</i>	<i>18</i>
<i>Relationship Between Parents’ Socio-Economic Background, Parental Involvement and Students’ Academic Performance in Higher Institutions of Learning in Adamawa State, Nigeria</i>	<i>25</i>
BUILT ENVIRONMENT, EARTH AND ENVIRONMENTAL SCIENCES	30
<i>Analysis of Trend and Dynamics of Urban Sprawl in Minna Niger State Nigeria</i>	<i>31</i>
<i>The Emerging Role of Pleadings in Determining Arbitrators’ Jurisdiction</i>	<i>35</i>
<i>Assessment of Financing Options for Housing Project Development in Lagos State, Nigeria</i>	<i>39</i>
<i>Embodied Energy and Carbon IV Oxide Emission Analyses of Sandcrete Blocks and Compressed Earth Bricks Houses</i>	<i>43</i>

<i>Land Development and Planning Regulations in Lokoja, Nigeria</i>	48
<i>The Roles of Town Planners in Disaster and Risk Management in Built Environment of Birnin Kebbi, Nigeria</i>	52
<i>Factors Critical to Industrialised Building System Performance of Nigerian Mass Housing Projects</i>	56
<i>Rental Housing Affordability: A Case Study of Millennium Estate, Ifako-Ijaiye, Lagos.</i>	60
<i>The Level of Students' Awareness on Maintenance of Sewer Blockage in Male Student Hostel Abubakar Tafawa Balewa University Bauchi, Nigeria</i>	64
COMPUTING AND COMPUTING ENGINEERING	67
<i>Real Time Face Recognition System based on Pattern Matching</i>	68
<i>Gender Classification based on Local Binary Pattern and K-Nearest Neighbour</i>	74
<i>From Smell Phenomenon to Smell Agent Optimization (SAO): A Feasibility Study</i>	79
<i>Error Correction Algorithm for SRAM Based FPGA</i>	86
<i>Optimized Forward Consecutive Mean Excision Algorithm for Adaptive Threshold Estimation in the Energy Detector</i>	92
<i>Real Time Universal Scalable Wireless Sensor Network for Environmental Monitoring Application</i>	97
<i>Pastoralist Optimization Algorithm (POA): A Novel Nature-Inspired Metaheuristic Optimization Algorithm</i>	101
<i>Design and Implementation of a Microcontroller Based Auto-Switch Power Controller</i>	106
<i>Performance Analysis of a Modified Otsu-based Constant False Alarm Rate (CFAR) Algorithm under Varying Signal to Noise Ratio in Radar Systems</i>	110
<i>Performance of the Recursive One-Sided Hypothesis Testing Technique under varying Signal to Noise Ratio Conditions in Cognitive Radio</i>	115
ENGINEERING AND ENGINEERING TECHNOLOGY	119
<i>Tribological Properties of Untreated Vegetable Oils as Automotive Shock Absorber Fluids</i>	120
<i>Coconut-Castor Oil Blend as Sustainable Basestock for IC Engine Oils: The Low-Temperature Fluidity</i>	124

<i>Toward Green Road Freight Transportation Trends: Truck Platoon Application</i>	129
<i>Model Identification and Comparative Study of DC Motor Speed Control for Set Point Tracking and Disturbance Rejection</i>	137
<i>Formation of Ceiling Boards by the Combination of Sugarcane Bagasse and Rice Husk</i>	144
<i>Prioritised Hybrid Automatic Transfer Switch with Two Generators Shift</i>	148
<i>Removal of Furfural from Lignocellulosic Hydrolysates for Improved Bioethanol Production: Current Trends and Challenges</i>	152
<i>Coordinated Application for Saving, Time, Energy and Money in a Smart-Home</i>	157
MANAGEMENT AND SOCIAL SCIENCE	161
<i>Benefits of Electronic Commerce Technology Adoption among Small and Medium Sized Enterprises in Nigeria</i>	162
<i>Impact of Liquidity Management on Profitability in Nigeria’s Banking Sector</i>	167
<i>Awareness and Readiness to Adopt Electronic Commerce by Small and Medium Firms in Borno State</i>	172
<i>Monetary Policy and Commercial Bank’s Lending Ability Nexus: The Case of Selected Banks in Nigeria</i>	177
<i>A Critical Review of the Relationship between Merger and Acquisitions and Firm’s Performance: The Moderation Effect of Corporate Governance</i>	182
<i>The Study of Impact Factors in Knowledge Management on Business Performance in Chinese Enterprises</i>	193
<i>Examine the Effect of Agricultural, Manufactured and Services (Value Added) on GDP Per Capita</i>	197
<i>Evaluate the Effect of Human Capital and Financial Development on Output Growth in Nigeria</i>	202
<i>A Literature Review of Employee Motivation</i>	207
<i>Auditing Standards and Auditors Performance: A Study of Nigerian Banks</i>	213
<i>The Dynamics of Governance and Accountability in Nigerian Public Service: A Backward Look for a Diagnostic Cure</i>	217
<i>Influence of Recreational Activities on the Wellness and Level of Participation among</i>	

<i>Middle Class Income Earners in Osogbo</i>	<i>221</i>
SCIENCE AND BIOSCIENCE	228
<i>Experimental Determination of Electrical Insulating Properties of Dry Coarse Sand and Dry Fine-Medium Sand in Comparison with those of MgO Powder by Ohm's Law Method.....</i>	<i>229</i>
<i>Effects of Fungal Degraded Cob Product Supplementation on Broiler Chicks' Diet: Performance and Histopathological Characteristics.....</i>	<i>234</i>
<i>Production and Moisture Content Optimization of Cellulase and Xylanase by Newly Isolated Rhizopus oryzaeUC2 using Raw Oil Palm Frond Leaves as Substrate in Solid State Fermentation</i>	<i>238</i>

CONFERENCE CHAIRS



Prof. Nor Haniza Sarmin
Universiti Teknologi Malaysia

It is our pleasure to welcome you all to the maiden edition of the International Conference on Global & Emerging Trends (ICGET). The theme of the conference is '*Global Trends: Visions, Opportunities and Challenges for a Sustainable Future*', hence, discussions, presentations and other activities during these three days will focus on this description of the journey to our collective future as mediated by trends in technological development. The various changes around



Dr. Kumar Laxman
Univ. of Auckland, New Zealand

us are only pointers to greater changes we can expect in the nearest future. Hence, transformations in the industrial sector, in communication and the entirety of human interaction places a demand on us researchers and academicians to become more pragmatic in our approaches and research, so we are prepared to take advantage of forums like ICGET. All delegates were enriched by the various sessions and we look forward to better research, and richer collaborations following ICGET 2018. Once again, our thanks to all VIPs, other speakers, special guests, representatives of various institutions and all local and international delegates. It is our hope that the experiences of ICGET 2018 will be remembered for a long time to come. Thank you very much and wishing you all the best.

PROGRAM CHAIRS



Dr. Bosede Iyiade Edwards
*Imagineering Institute,
Iskandar Puteri, Johor. Malaysia*

The International Conference on Global & Emerging Trends (ICGET) is geared towards the fulfilment of the vision of creating a platform for sound academic networking and showcasing of visionary, multidisciplinary research, developments, and technologies, in line with global trends. ICGET is an initiative of Global Trends Academy (GTA), a forum of seasoned academicians with a vision to raise the research bar in the developing world. It aims to do this by fostering academic and research collaborations among



Dr. Yusuf D. Opaluwa
*Federal Univ. of Technology
Minna. Nigeria*

researchers and institutions from developing economies and the rest of the world, and sponsor global intellectual gatherings as well as link researchers with international development opportunities and promote dissemination of research findings from various fields. Seasoned academicians, experienced and budding researchers, research students and intending scholars are all welcomed by the GTA team. ICGET 2018 is the first in its series, and it was indeed a rich experience for all participants. On behalf of the local and international organizing committees, I appreciate keynote speakers from Malaysia and America, all VIPs, plenary speakers and workshop facilitators from various parts of Nigeria, invited guests, institutional representatives, and all senior and upcoming researchers who made the ICGET 2018 experience a memorable one. We high hopes that ICGET 2018 will birth outstanding future collaborations among delegates. Thank you all.

CONFERENCE COMMITTEE

Dr. Bosede I. Edwards, Imagineering Institute, Malaysia	-General/Programme Chair
Dr. Yusuf D. Opaluwa, Fed. Univ. of Tech., Minna. Nigeria	-Programme Co-chair
Dr. Nyangwarimam O. Ali, Universiti Teknologi Malaysia	-Chairman, Secretariat Committee
Dr. Olakunle Elijah, Universiti Teknologi Malaysia	-Chairman, Publicity Committee
Caleb Chinedu George, Univ. Tun Hussein Onn, Malaysia	-Chairman, Media & Design Committee
Dr. Olagoke Oladokun, University of Maiduguri, Nigeria	-Chairman, Corporate Rel. & Protocols
Eberechukwu. N. Paulson, Universiti Teknologi Malaysia	-Chairman, Welfare Committee
Dr. Atilola Moses Idowu, Federal Polytechnic Offa, Nigeria	-Chairman, Logistics
Mr. Danboyi Amusuk, Universiti Teknologi Malaysia	-Chairman, Finance Committee
Mr. Olanrewaju Steve Edwards	-Member, Secretariat Committee
Mr. Stanley O. Esaduwha, Fed. Coll. of Educ., Yola. Nigeria	-Webmaster
Dr. Felix Olorunfemi, NISER, Ibadan, Nigeria	-Member, Scientific Committee
Dr. Baba Adams Ndalai, Fed. Polytechnic Idah, Nigeria	-Member, Scientific Committee
Dr. Banjo Adekiigbe, Fed. Polytechnic, Ede. Nigeria	-Member, Scientific Committee
Dr. Mallam A. Babikkoi, Fed. Coll. of Educ., Yola. Nigeria	-Member, Scientific Committee
Dr. Ademola Adeyemi, Fed. Polytechnic, Kebbi. Nigeria	-Member, Scientific Committee
Esther D. Kadarko, Univ. Technology Petronas, Malaysia	-Member, Scientific Committee
Dr. Ezekiel Ogunbode, Fed. Univ. of Tech., Minna. Nigeria	-Member, Scientific Committee
Dr. Hamman Tukur Gabdo, Baze University, Nigeria	-Member, Scientific Committee
Dr. Kalu Joseph Ufere, ATBU, Bauchi. Nigeria	-Member, Scientific Committee
Engr. Ademola B. Raheem, Universiti Teknologi Malaysia	-Member, Publicity Committee
Dr. Anthony Adjei Twum, Kumasi Tech. Univ., Ghana	-Member, Publicity Committee

KEYNOTE SPEAKERS



Dr. Mohamad Kasim Abdul Jalil
*Associate Professor of Mechanical
and Applied Mechanics & Design,
Universiti Teknologi Malaysia.*

Global Trends in Higher Education: Visions, Opportunities & Challenges for a Sustainable Future.

Higher education is increasingly seen by many countries as a major contributor to national revenue and economic development. In order to maintain global relevance, many leading universities throughout the world have focused on internationalising both teaching and research areas to drive continuous improvement of the quality assurance standards and international criterion of their education systems. Universiti

Teknologi Malaysia's experience in developing international education highlights major success factors that improve its global reputation as a higher education destination for international students. The opportunities, the associated challenges and the lessons learnt can inspire efforts in other parts of the globe, and especially in the developing world.



Futurist CHET W. SISK
*Life coach, Founder & President, Lead Global,
Denver, Colorado. Leadership development
specialist at World Assemblies of
Youth (WAY).*

Moving from Profit to Abundance: Trends Indicating the Rise of the Ubuntu (Sharing) Economy.

A perfect storm of events has materialized, forcing us to re-evaluate the current socioeconomic structure in the world. The Fourth Industrial Revolution, Climate Change and the emergence of Ubuntu (sharing) as a philosophical construct is providing fertile ground for people around the world to ask: How do we leverage the emerging technologies into creating

utopia? Is there an opportunity in climate change that will make us take a harder look at how we organize cities? How will a Southern African philosophy change the way we've constructed societies? Futurist Chet W. Sisk will share details of a proof of concept model that gives us a hint to answers. He'll also outline visionary and inspiring possibilities that our current world situation provides. His message is practical, hopeful and global.

LIST OF REVIEWERS

Prof. Temitope Oyedepo	<i>Adeleke University, Ede. Nigeria</i>
Dr. Felix Olorunfemi	<i>Nigeria Inst. of Soc. and Econs. Research (NISER), Ibadan. Nigeria</i>
Dr. Ahmed Kamaruddeen	<i>University College of Technology Sarawak, Malaysia</i>
Dr. Jacob O. Ikotun,	<i>Vaal University of Technology, South Africa</i>
Dr. John O. M. Igbafe	<i>Hanyang University, Seoul. South Korea</i>
Dr. Richard Adeyemi	<i>University of Pretoria, Lynwood, Pretoria. South Africa</i>
Dr. Binfa Bongfa,	<i>Federal Polytechnic, Idah. Nigeria</i>
Dr. Rafiu Oyeleke Brown,	<i>Kaduna State Polytechnic, Kaduna. Nigeria</i>
Dr. Christopher Heng Yii Sern	<i>Univeristi Teknologi Malaysia, Johor. Malaysia</i>
Dr. Edward Jaja,	<i>Port Harcourt Polytechnic, Rumuola</i>
Dr. Azli Yahya,	<i>Univeristi Teknologi Malaysia, Johor. Malaysia</i>
Dr. Ezekiel Ogunbode,	<i>Federal University of Technology, Minna. Nigeria</i>
Dr. Faisal Khan,	<i>University Of Swabi, Pakistan</i>
Dr. Haruna Chiroma,	<i>Federal College of Education, Gombe. Nigeria</i>
Dr. Hassan Abdulsalam	<i>Modibbo Adama University of Technology, Yola. Nigeria</i>
Dr. Esther D. Kadarko,	<i>Universiti Teknologi Petronas, Perak, Malaysia</i>
Dr. Jonathan Oke	<i>Ekiti State University, Ado-Ekiti. Nigeria</i>
Dr. Joseph Kalu	<i>Abubakar Tafawa Balewa University, Bauchi. Nigeria</i>
Dr. Temilola M. Adepoju	<i>Federal Polytechnic, Ede. Nigeria</i>
Dr. Akintunde M. Ajagbe,	<i>Durban University of Technology, Republic of South Africa</i>
Dr. Ademola Adeyemi	<i>Federal Polytechnic, Birnin Kebbi, Nigeria</i>
Dr. Olufunmilayo Ayodele,	<i>Oduduwa University, Ipetu-Modu. Nigeria</i>
Dr. Shafi'i Abdulhamid	<i>Federal University of Technology, Minna. Nigeria</i>
Dr. Sunday Ajeigbe	<i>Federal Polytechnic, Bida. Nigeria</i>
Dr. Yinka Titilawo	<i>Federal University, Ndufu-Alike Ikwo, Ebonyi. Nigeria</i>

ARTS AND EDUCATION

Using Outdoor Activity to Enhance the Understanding of Science Concepts among Students from Non-Science Background

Ahmed M.Kamaruddeen^{*}

Quantity Surveying Programme, University College of Technology Sarawak, Malaysia

*qamaruddeen@yahoo.com

Abstract— University programmes such as Technology Management programme requires students to be exposed to certain science or engineering related courses such as Engineering Science irrespective of their background. The lack of exposure to such courses often poses challenges to both teachers and students in the teaching and learning process. This paper, therefore, examines the influence of learning object and learning activity on the understanding of science concepts by non-science students. The experiment was performed using two groups of students in Technology Management programme in a Malaysian university. While the first group of students, in the first semester, were not engaged with learning object and sporting activities that demonstrated the concepts of speed, distance, and displacement, the second group of students were fully engaged with it in the second semester. The performance of students who were not engaged was compared with the performance of the engaged students. The descriptive statistics and analysis of variance were used to determine the differences between the students' performance in the first and the second semesters in Engineering Science course. The result showed that students' performance in the second semester after being engaged with the learning of object and sporting activities was better than the performance of the first semester unengaged students. The analysis of variance also showed a significant difference. The findings of this study suggest that engaging students with relevant learning objects or activity can enhance their understanding and facilitates knowledge transfer.

Keyword— Physics concepts; Teaching & Learning; Outdoor Activity; Engineering Science

1 INTRODUCTION

Teaching science related courses such as Engineering Science (physics) to a group of university students having no science background can be very challenging. Likewise, the students do find it very difficult in comprehending the knowledge to be transferred to them. Teachers who find themselves in such a situation have to devise innovative means of transferring the knowledge to the students for learning to take place. As a result, there is a fast growing interest among researchers on new pedagogical style and learning approaches to provide a more student-centred environment (Bannan, Cook, and Pachler, 2015; Beetham and Sharpe, 2013). However, each approach may be applicable to a specific set of students and environment. While the use of mobile phone may enhance the transfer of knowledge and knowledge construction (Kearney et al, 2015), Science and Engineering related courses such as Physics would require actual operation through outdoor activities to enable students easy acquisition of knowledge among the students (Vygotsky, 1978). In addressing the challenges of teaching Engineering Science (physics) to a Malaysian university undergraduate students of Technology Management programme having no science background, this article compared the academic performance of students in two groups. The first group in the first semester were not engaged in any outdoor activity. The second group in the second semester were engaged in outdoor activity related to the Engineering Science (Straight line motion in Physics).

2 LITERATURE REVIEW

Recently, scholars have increasingly focused on the best teaching methods that provide effective transfer of knowledge to the students. This concern has prompted the search for alternative teaching approaches that complement the traditional method of teaching. One of such common alternative approaches is the student-centred learning that empowers students to take charge of their learning process.

In promoting a more student-centred learning approach and minimising traditional teaching method also known as the teacher-centred learning approach, UNESCO (2012) and Christensen & Knezek (2018) pointed out the need for an instructional paradigm shift as a means to achieving a fundamental change in the way students learn. The student-centred learning is in line with the Vygotskian's (1978) classroom principles which anchor on the on social constructivism theory. It suggests that "Learning and development is a social, collaborative activity" and "Classroom activity should be reality-based and applicable to the real world" (Vygotsky, 1978). In the same line of reasoning, Lave &Wenge (1998) and Brown (1991) stated that learning should be a processes by which people share ideas and strategies to build solutions and innovations as they interact. Teaching experience has shown that students will likely interact or come together as a group when they are engaged through group assignment or projects. Engaging students outside the classroom enables them to acquire a comprehensive knowledge through experience

which becomes indelible. In this type of learning, academic knowledge or information is not acquired from only a source such as text books; learning is rather interiorised to enable students generate their knowledge through individuals' experiences (Costa, 2015).

Beyond the traditional teaching and learning which anchors on teacher-centred approach, classrooms should rather be a place for constructivist activities and communities of practices (Atif, 2013). In essence, classrooms can also be used to engage students with activities that can enhance their learning process as well as transferring of knowledge. Therefore, using the traditional teaching alone as a means of transferring knowledge to the learners has been challenged by scholars. This practice has been largely criticized because it is known to present concepts that can be found in standard textbooks and does not provide opportunity for learners' engagement and experience in a classroom (Atif 2013).

Past studies have shown that a single type of student centred learning might not be necessarily the best practice for a particular group of students or all fields of study. Consequently, scholars and educator have continuously been in search of the best approach and style to use for transferring knowledge to any particular group of students. Wang, Jou, Lv, and Huang (2018) separately examined the influence of model-based flipped classroom supported by modern teaching technology on students' overall performance in communication and cooperation, application and learning, curriculum learning, and participation. The model-based flipped classroom supported by modern teaching technology provided significant improvement and academic performance.

The Flipped classroom practice reverses the two phases of knowledge transfer and knowledge construction that take place in any traditional education process. While knowledge transfer happens when teachers teach, knowledge construction happens after the class but can only be achieved when the students do assignments, homework, actual operation or practice. In essence, knowledge construction among students in the traditional education system will largely depend on the extent of their engagement through practice. In the same vein, Resnick (1987) affirmed that the means by which learner's process, absorb, and apply learned knowledge is largely dependent on the methods of using existing knowledge, experiences, and cognition to interpret new external information on the part of the learners.

In Flipped classrooms, knowledge transfer happens after the class and knowledge is constructed in the classrooms. The former is achieved with the support of information technology while the latter is completed in classrooms with the help of teachers and fellow classmates. The practice of flip classrooms aims to improve the students' acquisition of knowledge, increasing opportunities for knowledge construction and reducing the difficulties encountered in the learning process (Wang et al. 2018).

The free fall motion experiment has advanced our understanding of the mechanism of knowledge construction among students. The outcome of the experiment suggests that while students may physically demonstrate new and correct scientific constructed concept, their knowledge will not be reconstructed. The students will instead acti-

vate correct concepts while suppressing existing preconceptions after accepting the new knowledge (Petitto, Holowka, Sergio, Levy, & Ostry, 2004). This experiment has demonstrated that for the knowledge construction process to happen, pre-conceptions must be suppressed without any disruptive reconstruction taking place. Hence, the routes of constructing knowledge involve the process of assimilation or accommodation. Knowledge construction has been described as progressive suppression of previous impressions similar to the processes of assimilation and accommodation. Knowledge construction is not a sudden transformation, but a constant and gradual process (Wang, Lv, Jou, & Zhang, 2016).

Unpinned by the cognitive-development theory, assimilation has been described "as the process by which new external stimulus is incorporated into existing cognitive structures of an organic entity and how new knowledge adapts to existing information; accommodation is where the host changes its own cognitive structure to adapt to new changes to the environment" (Wang, Lv, Jou, & Zhang, 2016).

3 METHOD

3.1 Procedure of Outdoor Activity

Students were instructed to download a recorded football match of their choice from YouTube. Prior to watching the football match, they were asked to draw a football field to scale on an A4 paper. While watching the football match, they were told to concentrate on any kick of the ball or shoot that led to scoring. The position of the footballer that kicked or shot the ball was marked on the A4 paper. The time the ball was kicked and entered into the goal post was recorded. The approximate distance of the ball from the point of kicking to the goal post was obtained by marking the similar point physically on a real football field and measured physically using a tape rule. The speed of the ball was obtained by dividing the distance of the ball by the time it took the ball to reach the goal post. The difference between the ball displacement and distance travelled by the ball was obtained.

3.2 Data Collection

The collected data were the end of semester results for two semesters. The two semesters were labelled Semester A121 and A122 based on the actual semester code used by the university in which the research was conducted. In semester 121 (first semester), the students were taught in the classroom but were not engaged in outdoor activity like it was done in semester 122 (second semester). The end of semester result constituted 60% coursework (assignments and test). The remaining 40% was for the end of semester examination.

4 RESULTS AND DISCUSSION

4.1 Results

The end of semester results of the 115 students in semester A121 comprising 47 students (40.9%) and A122 semester comprising 68 students (59.1%) were analysed using descriptive statistics. As shown in Table 1, the comparative

results of the two semester students indicated that in semester A121, no student score "A+", 17.1% scored "A", 19.1% scored "A-", 19.1% scored "B+", 17% scored "B", 6.4% scored "B-", and 17% scored "C+". In semester A122, 5.9% scored "A+", 45.6% scored "A", 16.2% scored "A-", 20.6% scored "B+", 4.4% scored "B", 2.9% scored "B-" and only 1.5% scored "C+".

Table 1: Examination Results of Two Groups of Students

Grade	A121		A122	
	Frequency	Percentage	Frequency	Percentage
A	8	17.0	31	45.6
A-	9	19.1	11	16.2
A+	-	-	4	5.9
B	8	17.0	3	4.4
B-	3	6.4	2	2.9
B+	9	19.1	14	20.6
C	1	2.1	1	1.5
C-	-	-	1	1.5
C+	8	17.0	1	1.5
F	-	-	-	-
X	1	2.1	-	-

Figure 1 depicts the mean of the examination marks of Semester A121 and A122. The course work accounted for 60 percent of the overall semester result and the remaining 40 percent was the final exams. Both coursework and final exam amounted to 100 percent of the total mark.

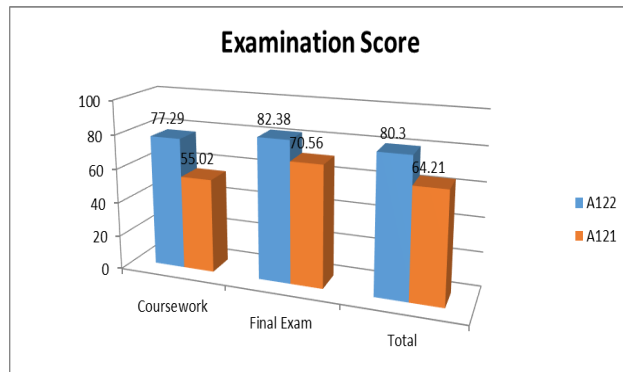

Figure 1: Mean of Semester A121 and A122 Results

For the coursework, results indicated that students from semester A122 semester had the highest average score (mean=77.29) compared to the other groups of students in semester A121. Similar results was also found on the final exams in which the students from the same semester A122 scored the highest marks (mean=82.38) compared with A121 (mean = 70.56). Overall results also indicated that students from A122 semester had the highest score (mean=80.30).

Figure 2 presents the percentage of the various grades among the students in semester A121 and A122. The percentage of the students in Semester A121 that scored "A" and "A-" was 36.1%. The percentage of the students that scored grade "B+" was 19.1%. Grade "B" was 17.0% and grade "B-" was 6.4%. A better result was produced by stu-

dents A122 in which 5.9% scored "A+", 45.6% scored "A" and 16.2% scored "A-".

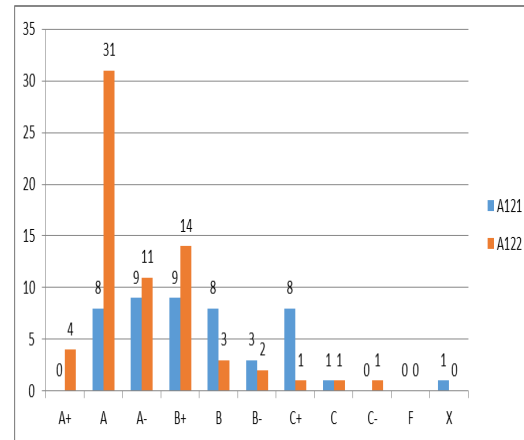

Figure 2: Frequency of the various grades in semester A121 and A122

Table 2 presents the mean score of the examination marks. The final semester results consisted of 60 percent of coursework (assignment and test) and 40 percent from the final exams. In semester A121, the mean score obtained was 77.27% which accounted for 66.37% of coursework. In the end of the semester examination, the mean score was 55.02% which accounted for 22.01% of the final semester examination. In semester A122, the mean score was 82.38% which accounted for 49.46% of the coursework. Mean score in the end of semester examination was 70.56% which accounted for 28.22% of the end of semester examination. The total mean score in semester A122 was 77.75% compared with 68.49% in semester A121.

Table 2: Mean of Semester A121 and A122 Results

	Mean	
	A121	A122
Coursework	77.29	82.38
60 percent	46.37	49.46
Final Exam	55.02	70.56
40 percent	22.01	28.22
Total (100%)	68.49	77.75

Table 3 shows the comparison of the mean result and independent sample t-test to examine the differences between the performance of the two groups of students in semesters A121 and A122. For the coursework, results indicated that students' performance from A122 semester had the highest average score (mean=82.38) compared to the other group of students in semester A121. Similar results in the final exams revealed that the performance of students in semester A122 had the highest score (mean=70.56). Overall results also indicated that students' performance from semester A122 had the highest score (mean=77.75). Result of independent sample t-test indicated statistical significant differences between the result of semester A121 and A122. The overall results were as follows: coursework (t=-2.833, p<0.01), final exam (t=-4.563, p<0.01) and total score (t=-4.438, p<0.01).

Table 3: ANOVA for Semester A121 and A122 Results

	Semester (mean)		T	Sig.
	A121	A122		
Coursework	77.2851	82.3825	-2.833	0.005
Final Exam	55.0213	70.5588	-4.563	0.000
Total	68.4894	77.7500	-4.438	0.000

4.2 Discussion

The higher academic performance demonstrated by students in semester A122 suggests that the sport outdoor activity that was used to engage the students has a significant impact on their learning and knowledge construction. The highest and lowest grade scored in both semester are four (4) "A+" and three (3) "C- to C+" grade in semester A122 compared to Semester A121 in which no student scored "A+" grade and a total of 9 students scored the "C to C+" grade. It can therefore be inferred that outdoor activities can enhance students' learning process. The findings of this paper complement the existing body of knowledge on the impact of outdoor activities on students learning process (Lave & Wenge, 1998; Brown, 1991; & Costa, 2015).

5 CONCLUSION

This paper has advanced our understanding on the impact of using outdoor activities to enhance students' learning process. This paper has demonstrated that students with no science background can still be taught basic science concepts by incorporating outdoor activities into their learning process. This paper has demonstrated that the engaged students in semester A122 performed better than the unengage students in semester A121. The difference in the class size of the students in semester A121 and A122 is a major limitation to this paper. Future research could examine the same set of students to minimize the diversity among two groups of students.

ACKNOWLEDGMENT

The author acknowledges the financial support from the University College of Technology Sarawak Staff Development Scheme.

REFERENCES

[1] T. Atif, "Conversational learning integration in technology enhanced classrooms," *Computers in Human Behavior*, vol. 29, pp. 416 - 423, 2013.

[2] B. Bannan, J. Cook, and N. Pachler, "Reconceptualizing design research in the age of mobile learning," *Interactive Learning Environments*, vol. 24, no. 5, pp. 938 - 953, 2015.

[3] H. Beetham, and R. Sharpe, *Rethinking pedagogy for the digital age: Designing for the 21st century learning*, New York, NY: Routledge, 2013.

[4] J. Brown, "Organizational learning and communities-

of-practice: Toward a unified view of working, learning, and innovation," *Organization Science*, vol. 2, p. 40-57, 1991.

[5] R. Christensen, and G. Knezek, "Reprint of Readiness for integrating mobile learning in the classroom: Challenges, preferences and possibilities," *Computers in Human Behavior*, vol. 78, pp. 379 - 388, 2018.

[6] T. Costa, "Learning through experience and teaching strategies outside the classroom at design university studies," *Procedia - Social and Behavioral Sciences*, vol. 196, p. 35 - 40, 2015.

[7] M. Kearney, K. Burden, and T. Rai, "Investigating teachers' adoption of signature mobile pedagogies," *Computers & Education*, vol. 80, pp. 48-57, 2015.

[8] J. Lave, and E. Wenge, "Communities of practice," Cambridge University Press, 1998.

[9] L. A. Petitto, S. Holowka, L. Sergio, B. Levy, and D. Ostry, "Baby hands that move to the rhythm of language: Hear-ing babies acquiring sign languages babble silently on the hands," *Cognition*, vol. 9, pp. 43 - 73, 2004.

[10] L. B. Resnick, "Learning in school and out," *Educational Researcher*, vol. 16, pp. 13 - 19, 1987.

[11] UNESCO, "Working paper series on mobile learning: Turning on mobile learning in North America," UNESCO, 2012.

[12] L. Vygotsky, "Mind in society," Harvard University Press, 1978.

[13] J. Wang, M. Jou, Y. Lv, and C. C. Huang, "An investigation on teaching performances of model-based flip-ping classroom for physics supported by modern teaching technologies," *Computers in Human Behavior*, vol. 84, pp. 36 - 48, 2018.

[14] J. Y. Wang, Y. Z. Lv, M. Jou, and J. B. Zhang, "Research on the effects of cloud-based pedagogy for creative talents: A case study on Chinese high school," *Computers in Human Behavior*, vol. 63, pp. 229 - 239, 2016.

Effects of Implementation of Problem-Based Learning on Students 'Academic Achievement and Attitudes Towards Learning Chemistry

Abbas A. Babayi* and Dahiru B. Hammanjulde

Department of Chemistry, Federal College of Education, Yola, Adamawa State, Nigeria.

*abbasbabayi@gmail.com

Abstract - This study aimed to determine the effects of problem-based learning on students' achievement and attitudes towards chemistry. Quantitative method was used. Data were obtained via pre/post-test, treatment-control groups and attitude questionnaire administration. The population was all NCE II chemistry students of Federal College of Education, Yola. Purposeful sampling technique was used in selecting a sample of fifty (50) students divided into experimental (EG) and control (CG) groups. Chemistry Achievement Test (CAT) and open-ended attitude scale questionnaire were used. The instruments were subjected to experts' opinion, their comments and observations were effected for validity. The experimental group was taught using problem-based learning approach for a period of 30 class hours and a traditional lecture method was employed on the control group. Questionnaire was administered on the experimental group. The data were analyzed using t-test and descriptive statistics. Findings revealed that, implementation of problem-based learning had positive effects on students achievement and attitudes towards learning chemistry. It also revealed that gender has no effect on students' achievement when expose to PBL. The researchers concluded that PBL enhances students 'achievement and attitude toward chemistry. They recommended for government and private sectors to encourage teachers adapt PBL approach, improve infrastructure, welfare of students and teachers through adequate funding.

Keywords: Achievement; Attitude; Chemistry; Effects; Problem-based learning.

1. INTRODUCTION

STUDENT'S ability to make connection with real life situations is important as these abilities are needed by their employers. The present science curricula being implemented are always criticized of not producing students with enough experience and skills to solve problems and challenges of the imagined global trends [1]. The basic aim of education is to enable individuals become effective problem solvers. It is therefore important for students to face real problems in their learning environment and proffer appropriate solutions to these problems [2][3]. The most convenient approach for achieving this in learning environments is the use of student-centered approach of learning such as the problem-based learning (PBL). The global emerging trends in the pedagogical practices are approaches where learners take the responsibility of their learning and the opportunity to participate adequately in learning process as the teacher become a guide. These approaches helps students develop problem-solving skills and higher achievement in learning [4]. PBL is rooted in Dewey's "learning by doing and experiencing" principle [5].

2.0 LITERATURE REVIEW

Lecture method of teaching chemistry has been practiced for a long period in secondary and tertiary education where teacher dominates the learning process through lec-

tures and note taking. Students had to connect what they learn from the superficial abstract contents delivered by teachers in classes with the real world life problems in the society [6]. After more than two decades of lecture method of teaching which fails to yield positive effects on students learning, constructivism theory of learning supporting student-centered learning process is getting more attention of stake holders in education. The theory emphasizes more on knowledge construction by the students not knowledge transmit ion from the teachers to students [7].

2.1 Implementation of Problem-Based Learning In Chemistry Education

PBL, learning process start with real world problems; It contents and practices must be attractive to students. The students must be encouraged to have adequate time to collect information and set strategies of solving problems [8]. PBL enable students see events across disciplines. Although teachers have difficulty to change teaching styles and it is time consuming [9][10]. PBL engaged students to learn through presentations and interactions in groups and places more responsibility of comprehension on them; this improved their learning and development of problem solving skills, thus translate into higher students achievements [11][12]. PBL is very effective in enhancing student achievement in chemistry and it is gender friendly as both male and female showed equally improved achievement [13]. PBL has effect on student achievement. "therefore it is more effective than lecture method. PBL strategies

are connected to students' future careers, it encourages them to search for solutions to the problems in class rooms and every day lives. This enables them understand the connection between science classes and situation in the society, hence they develop interested, positive attitude towards learning and achievement more [14].

2.2 Objectives of the Study

Despite the implementation of PBL in many parts of the world, it is still however a new experience in Nigerian science curriculum. The efficiency of PBL need to be explored considering its limitations to enable students acquire problem solving skills and improve learning but not to be afraid of problems. The objective of this research is to determine whether the implementation of PBL in tertiary education brings about significant differences in students' achievement and their attitudes towards learning chemistry. Also if there is difference in the achievement due to gender. To achieve this objective, the following null hypotheses were tested:

Ho₁: There is no significant difference in the academic achievement of students taught chemistry using PBL and those taught using lecture method of teaching.

Ho₂: There is no significant difference in the academic achievement of boys and girls when exposed to PBL.

Ho₃: There is no significant difference in the attitude towards chemistry by students taught using PBL and those taught using lecture method.

3.0 METHODOLOGY

This research used quantitative approach and quasi-experimental & control groups design. The population is all NCE II chemistry students in F.C.E. Yola, Nigeria. Purposeful sampling technique was used in selecting a sample of fifty (50) students divided into experimental (EG) and control (CG) groups. Data was collected through Chemistry Achievement Test (CAT) containing (30) structured multiple choice items and 12 itemed attitude questionnaire. The instruments were handed to experts for validity assessment. The two groups were pretested for their equivalence in ability using (CAT). The (EG) was then taught chemistry using PBL for thirty (30) class hours while the (CG) was taught using the lecture method for the same period. A post-test was conducted to both groups using (CAT) to determine the effects of the PBL on students' achievement. An attitude questionnaire was also administered to the (EG) to determine their attitude towards the PBL. The data was analyzed using t-test and descriptive statistics.

4.0 RESULTS AND DISCUSSION

4.1 Null Hypothesis Ho₁:

There is no significant difference in the academic achievement of students taught using PBL approach and those taught using lecture method. To test this hypothesis, the

post-test scores of the (EG) and (CG) were analyzed using t-test statistics. The result of the t-test analysis is shown in Table 1.

Table 1: Result of t-test Analysis of Post-test Scores of (EG) and (CG)

Group	N	Mean	df	t-cal.	t-critical $\alpha = 0.05$
Exp'tal	25	70.80	24	12.35	2.06
Control	25	58.23			

From Table 1 the t-calculated of 12.35 is greater than the critical t-value of 2.06 at 0.05 level of significance and degree of freedom of 24. This mean, there is significant difference in achievement of the (EG) and the (CG) in (CAT). This shows that the students in the (EG) achieved higher than those in the (CG) in (CAT). The mean score (70.80) of the (EG) is also higher than the mean score (58.23) of the (CG) as shown in Table 2. This indicates that the (EG) exposed to PBL approach performs better than the (CG) exposed to lecture method. Based on the result, the null hypothesis (Ho₁) is therefore rejected. The PBL approach is therefore more effective in improving student's achievement than the lecture method. This finding is in line with the report that collaborative learning activities of PBL generates high frequency of students' interactions, development of problem solving skills, improved learning, this translates to higher students achievements [8]. The finding is also supported by [11] who reported that PBL is very effective in increasing students' achievement in chemistry than the Lecture method. It is also in support of the report that students taught using PBL approach are more successful than those taught with traditional lecture methods [3].

4.2 Null hypothesis 2: Ho₂:

There is no significant difference in academic achievement of boys and girls when exposed to PBL approach of chemistry teaching. To test the hypothesis, the post-test scores of the (EG) was also analysed using t-test statistics. The result of the t-test analysis is shown in Table 2

Table 2: Result of the t-test Analysis of Post-test Means Scores for the (EG)

Gender	N	df	t-cal	t-critical $\alpha = 0.05$
Boys	10	9	0.94	2.26
Girls	10			

From Table 2, the calculated t-value of 0.94 is less than the critical t-value of 2.26 at 0.05 level of significance and degree of freedom of 9. These results indicate that there is no significant difference in the achievement of boys and girls when taught chemistry using PBL. This implies that boys and girls perform equally well when exposed to PBL approach. Therefore the null hypothesis (Ho₂) is upheld. The

finding is supported by research report that PBL is gender friendly as both male and female showed equally improved achievement when taught chemistry [11].

4.3 Null hypothesis (H0):

There is no significant difference in the attitude towards chemistry by students taught using PBL and those taught using lecture method. To test this null hypothesis 3, the questionnaires analyses using descriptive statistics as shown in Table 3.

4.3: Table 3: Analysis of responses of (EG) attitudes towards chemistry

Questionnaire item no.	1	2	3	4	5	Mean	Std
	Frequencies						
1.	0	2	6	12	10	4.00	0.91
2.	0	0	4	14	12	4.26	0.69
3.	0	2	6	10	12	4.06	0.94
4.	0	6	4	10	10	3.80	1.10
5.	0	2	6	12	10	4.00	0.91
6.	0	4	6	10	12	3.86	1.04
7.	0	4	2	14	10	4.00	0.98
8.	2	0	4	12	12	4.06	1.08
9.	4	0	6	10	10	3.73	1.31
10.	0	2	6	14	8	3.93	0.86
11.	0	4	2	12	12	4.06	1.01
12.	0	4	6	10	12	3.86	1.04

Note: [1= strongly disagree, 2= Disagree, 3= Neutral, 4= Agree, 5= strongly agree & Std= Standard deviation.

Table 3 shows that the students have positive attitudes and high level of satisfaction toward learning chemistry because of their PBL experiences. It is also clear from the table, that all the mean scores of (EG) responses are greater than 3.0 and most of the standard deviations (Std) are approximately 1. Therefore there is a significant difference in the attitudes towards chemistry of (EG) and (CG), hence the null hypothesis (H0) was rejected. This finding is supported by the research reports that students exposed to PBL experiences shows positive attitudes and good satisfaction towards learning chemistry [2]. The collaborative and self-directed learning activities of the PBL develop students' higher-order thinking skills and positive attitudes towards learning science [14].

5.0 CONCLUSION

Based on the findings of this study, the researchers concluded that the implementation of PBL improved both male and female students' achievement and attitude toward learning chemistry.

6.0 RECOMMENDATIONS

Based on the conclusions, the researchers recommended

that stake holders in education should discourage lecture method and encourage students-centered approach (PBL) that is more effective to enhance students' achievement. They should provide adequate funds for infrastructure and the welfare of staff and students.

REFERENCES

[1] D.Laboy-Rush. Integrated STEM Education through Project-Based Learning.com White-Paper 101207 final,2011

[2] J.T.Walker & S.P.Lofton. Effect Of a Problem Based Learning Curriculum On Students' Perceptions,2003.

[3] C.Chin&L. G.Chia. Problem-Based Learning: Using Students' Questions to Drive Knowledge Construction, *Science Education*, 88(5), 707-727,2004.

[4] P. Nwamno and A. Izuagba. Teacher Education and Challenges of the Millennium Development Goals. *European Journal of Social Sciences*,1:(7), 91-95,2010.

[5] J. Dewey. *Experience and Education*. A Touchstone Book, Kappa Delta Pi, New York,1938.

[6] C.Chin. Classroom Interaction in Science: Teacher Questioning and Feedback to Students' Responses. *International Journal of Science Education*, 28:(11), 1315-1346,2006.

[7] S. Han, M.M. Capraro and R.M.Capraro.In-service Teachers Implementation and Understanding of STEM Project Based Learning, 11(1), 63-76,2015.

[8] H. S.Barrows. Problem-based Learning in Medicine and Beyond: A brief Overview. *New Direction for Teaching and Learning*, 68: 3-12, 1996.

[9] C., A.Collazos, L., A.Guerrero, and J. A.Pino. Computational Design Principles to Support the Monitoring of Collaborative Learning Processes. *Journal of Advanced Technology for Learning*, 1 : (3), 174-180, 2001.

[10] O.Akani.. Levels of Possession of Science Process Skills by Final Year Students of Colleges of Education in South-eastern States of Nigeria.*Journal of Education and Practice*, 6: (27), 94-101,2015.

[11] S.S.Ahmad. The impact of Context-based Instructional Approach on Students Academic Achievement and Retention of Hydrocarbon Concepts Among Science Secondary Students in Kano State, Nigeria. *Proceedings of the 2nd International Conference on Science, Technology and Social Science (ICSESS2016)* . University of Technology Malaysia, 2016.

[12] A. Walsh.*The Tutor in Problem-based Learning: A Novice's Guide*. Canada: McMaster University Press.

[13] C.E.Hmelo-Silver (2004)"Problem-based Learning: What and How Do Students Learn?" *Educational Psychology Review*, 16: 235-266, 2005.

[14] B. A.Abbas, and M. Y. Arshad. Collaborative Learning and Skills of Problem-based Learning: A case of Nigerian Secondary Schools Chemistry Students, *Asian social Science*, 11 :(27), 53-62,(2015).

Language Learning Motivation in Global Context: From Integrativeness to the Ideal L2 Self

Wang Zhe

Faculty of Education, Universiti Teknologi Malaysia, 81310 Johor, Malaysia

louisawang2016@gmail.com

Abstract - The spread of globalization brings about the emergence of English using as lingua franca nowadays, which leads to the changes in understanding motivation of learning English in this global context. In this paper, the researcher will firstly critically examine the concept of 'integrativeness', which is the essence of the predominant socio-educational model of L2 motivation. Furthermore, the researcher will clarify the need to re-conceptualise the concept of 'integrativeness' by revisiting recent empirical research on L2 motivation. It is argued that, as English becomes a lingua franca in the globalization context, there could be no clear target language group into which L2 learners could integrate, especially for Foreign Language learners (EFL), undermining the concept of 'integrativeness'. Finally, the Dörnyei's L2 Motivational Self System will be presented which re-conceptualises 'integrativeness' of L2 motivation from the self-perspective.

Keywords: language learning motivation, integrativeness; English as a global language

INTRODUCTION

Motivation has been the focus of second/foreign language learning research for decades. It provides the primary impetus to initiate L2 learning and later the driving force to sustain the long and often tedious learning process; indeed, all the other factors involved in SLA presuppose motivation to some extent (Dörnyei, 2005). The L2 learners might be frequently demotivated and "the common experience would seem to be motivational flux rather than stability" (Ushioda, 1996, p. 240). In such situations, sustaining effort and motivation during and across various educational periods seems to have a pivotal role in the learners' success in mastering a second language.

For decades, the previous research on L2 motivation has mainly based on the socio-educational model proposed by [1] (Gardner, 1985) in which integrativeness plays as the most influential factor in L2 achievement (MacIntyre, MacKinnon, & Clément, 2009; Ryan, 2009).

However, the spread of globalization brings about the emergence of English using as lingua franca nowadays. The communication in English between so-called native and non-native speakers, together with those between only native speakers, only make up part of global interaction today (Dörnyei, 2010). The interactions between non-native speakers become dominant and it leads to the rise of Global English (Crystal, 2003). Therefore, integrativeness referring to the desire to learn an L2 of a valued community so that one can communicate with the members of the community and sometimes even to become like them (Gardner, 2001) is absent in foreign language learning context.

In this article, the researcher firstly critically examines the concept of integrativeness which is the essence of traditional socio-psychological model of L2 motivation (Gardner, 1985). Furthermore, the researcher will make an attempt to re-conceptualise the concept of 'integrativeness' by considering recent empirical research on L2 motivation in global context in which among most L2 learners is no longer concerned with 'integrativeness' in the target L2 culture or community. Finally, the new motivation theory

of Dörnyei's L2 Motivational Self System will be presented which re-conceptualises the concept of 'integrativeness' from the self-perspective in global context.

1. THE CONCEPT OF INTEGRATIVENESS IN GARDNER'S SOCIO-EDUCATIONAL MODEL

Based on the results of a number of studies, including those by Gardner and Lambert (1972), Gardner and Smythe (1975) proposed a model of L2 acquisition, the Socio-Educational Model. The model assumed that language achievement is influenced by integrative motivation, language aptitude, as well as a number of other factors. The most elaborate and researched aspect of Gardner's motivation theory was the concept of the integrative motive, which is defined as a motivation to learn a second language because of positive feelings towards the community that speaks the language'. The integrative motivation is made up of three main components: Integrativeness, Attitudes toward the Learning Situation and Motivation. Integrativeness refers to the desire to assimilate into the target language community (Gardner & Lambert, 1972). It also includes the desire to learn a L2 in order to meet and communicate with members of the L2 community. In contrast to integrative motivation, there is another important concept in Gardner's model, namely, 'instrumental motivation' for a specific aim, such as fulfilling a language requirement at school or qualifying to get a better job.

According to Masgoret & Gardner (2003) all the three components of integrative motivation are positively related to L2 achievement. Motivation is regarded as the major component contributing to L2 achievement and integrativeness and attitudes toward the learning situation are two different but correlated variables supporting L2 motivation. In other words, integrativeness and attitudes toward the learning situation indirectly impact L2 achievement through motivation. They also have claimed that the language learning context (second or foreign language context) has little effect on the relationship between integrative motivation and L2 achievement.

1. THE NEED TO RE-CONCEPTUALIZE THE CONCEPT OF INTEGRATIVENESS IN GARDNER'S SOCIO-EDUCATIONAL MODEL: EMPIRICAL FINDINGS OF L2 MOTIVATION RESEARCH

For many decades, the socio-educational model proposed by Gardner(1985) has been the dominant theory in L2 motivation research and integrative motivation maintains the central position as the most influential factor of L2 achievement (MacIntyre et al., 2009; Ryan, 2009). However, over the past two decades motivation researchers have increasingly recognized that motivation is a complex, multi-faceted construct that cannot be defined adequately in terms of the instrumental/integrative dichotomy (Ushioda & Dörnyei, 2009).

2.1 Empirical Findings of a Lack of Integrativeness in EFL Context

The researchers argued that the concept of 'integrativeness' which is a central component of socio-psychological research representing the desire to identify and mix with English-speaking people and their culture Gardner(1985) became invalid in many languages learning environments outside of the Canadian context where it had originated(Crookes & Schmidt, 1991; Dörnyei, Csizér, & Németh, 2006; Dörnyei, Csizér, & Németh, 2006).Furthermore, due to the spread of globalization, the rise of growing status of English as a global language (Crystal, 2003)and an international lingua franca(Jenkins, 2007) makes it difficult to explain motivation for learning English as a process of identification with a specific linguistic and cultural community.The lack of identification with native speakers of English was empirically demonstrated in a variety of contexts (Lamb, 2004; Warden & Lin, 2000; Yashima, 2000). In particular, those individuals tended to connect themselves to an imagined general global community, instead of a specific country (Lamb, 2004; Yashima, 2000).

In China, Liu(2007) investigated Chinese university students'attitudes towards and motivation to learn English. The investigation was conducted from Social Psychological perspective to explore the aspects of integrative and instrumental orientation among the Chinese EFL learners. Three components of motivation were addressed in the survey: Integrative Orientation, Instrumental Orientation and Travel Orientation. The findings revealed that the students were more instrumentally than integratively motivated to learn English, and that the students' attitudes and motivation were positively correlated with their English proficiency. According to Liu (2007), most of the students were not integratively oriented because they had little contact with English native speakers in their daily life. In addition, the students' high scores on Travel Orientation indicated that they hold the view that English can facilitate their travel and life abroad.

In China Taiwan, Warden and Lin (2000) findings indicated a lack of integrative motivation among Taiwan EFL learners.'This preliminary study has discerned the existence of two motivational groups and two temporal orientations in the Taiwanese EFL environment. An integrative motivational group is notably absent'. (p. 544).Therefore, they argue that these students might in-

tend to associate their English with career improvement or at least the potential for improving future careers. In other words, learning English for these Taiwanese students is not related to integrate with English native speakers. Chen, Warden, and Chang (2005) also discovered that the integrative motivation played no significant role in motivating language learning effort in the Chinese cultural environment.

In the context of Japan, Yashima(2000) stated that "causal relations proposed in Gardner's model, although here integrativeness was replaced with two orientations instrumental and intercultural friendship orientations which had been operationally defined as most important in the Japanese English learning context"(p. 131). Furthermore, to extend the concept of integrativeness to a generalized international outlook, she proposed a new term "International Posture"---the concept postulated for EFL contexts as an alternative to concept of *integrativeness*, referring to "interest in foreign or international affairs, willingness to go overseas to stay or work, readiness to interact with intercultural partners, and [. . .] openness or a non-ethnocentric attitude toward different cultures" (Yashima, 2002, p. 57). Dörnyei (2005)pointed out that this variable appears to be similar to 'international orientation', which Nakata(1995) found to be an important individual difference variable among Japanese learners, involving a general cosmopolitan outlook. Irie(2003) also mentioned that the integrative-instrumental orientation dichotomy might not be compatible with Japanese students learning a foreign language in Japan and found the ambiguity of disposition toward integrative motivation. Irie(2003, p. 91) also points out, "One of the most noticeable recurring patterns found in Japanese EFL university contexts are a positive orientation to foreign travel without any apparent desire to integrate into the TL culture."

2.2 Empirical Findings of Blurry Distinction between Instrumental Motivation and Integrative Motivation

Another criticism on the conceptual problem of Gardnerian construct of integrativeness is the blurry distinction between 'instrumental motivation' and 'integrative motivation'.In other words, it is very difficult to separate the instrumental motivation from integrative motivation in Gardner's (1985)model.

In a study investigating the motivation types of English learning among Chinese undergraduates, Gao et al.(2004)suggest that"the classical instrumental-integrative division has not precisely accommodated the subtle and multi-folded motivations of the Chinese learners"(p60). In Japan, Kimura, Nakata, and Okumura(2001)study indicated that the largest motivational factor in English language learning among Japanese language learners is complex, combining with intrinsic, integrative and instrumental motivations. Based on a study in Indonesia, Lamb(2004) also drew a similar conclusion that it is difficult to distinguish integrative and instrumental orientations as separate concepts and are actually associated with each other.As Lamb (2004) argued, "meeting with westerners, using pop-songs, studying and traveling abroad, pursuing a desirable career—all these aspirations are associated with each other" (p. 15).

To summarize, Gardner's Socio-Educational Model has been under attack in two terms. Firstly, the traditional concept of integrativeness involves integration with the L2 speaking community. However, in the current global world in which English is used as an international language, there is the lack of the L2 community to integrate with in the case of English. Especially, for learners in foreign language contexts, integration with English native speakers is irrelevant with learning motivation. Secondly, as the emergence of English using as lingua franca, the pragmatic advantages of speaking English and the attitudes towards L2 community have become intricately blended so that distinction of integrativeness and instrumentality becomes blurry.

3. NEW THEORY OF L2 MOTIVATION IN GLOBAL CONTEXT: L2 MOTIVATIONAL SELF SYSTEM

3.1 Components of L2 Motivational Self System

Given the drawback in the traditional framework of Gardner (1985), Dörnyei et al., (2005, 2009) drew on and summarized well-known paradigms from L2 motivation research (Noels, 2003; Ushioda, 2001), and motivational psychology: self-discrepancy theory (Higgins, 1987) and theory of possible selves (Markus & Nurius, 1986), and proposed the L2 Motivational Self System as a model which is comprised by three main dimensions, namely, the ideal L2 self, the ought-to L2 self, and English learning experience. *Ideal L2 Self*, which is the L2-specific facet of one's 'ideal self'. If the person we would like to become speaks an L2, the 'ideal L2 self' is a powerful motivator to learn the language. *Ought-to L2 Self*, which concerns the attributes that one believes one ought to possess to meet expectations and to avoid possible negative outcomes. *L2 Learning Experience*, which concerns situated motives related to the immediate learning environment and experience (e.g. the impact of the teacher, the curriculum, the peer group, the experience of success).

According to Dörnyei (2009), motivation is the result of someone's wish to reduce the discrepancy between one's ideal self (i.e., one's image of what one would like to become) and one's actual self (i.e., one's actual self-state). From the self-perspective, the concept of 'integrativeness' could be interpreted as the L2-specific facet of one's ideal self. Dörnyei (2009) also argued that if the L2 learner's ideal self is connected with the mastery of an L2, this could be conceived as an integrative motivation in Gardner's (1985) model. The essence of the new theory is to validate the equation of the traditional 'integrativeness' and the Ideal L2 Self.

3.2 Research into Validation of L2 Motivational Self System

According to Dörnyei (2011), during the last few years, L2 Motivational Self System has been empirically tested and validated in a variety of contexts including Japan, China and Iran (Papi, 2010; Ryan, 2009; Taguchi, Magid, & Papi, 2009), Hungary (K. Csizér & Kormos, 2009; Kata Csizér & Lukács, 2010), Chile (Kormos, Kiddle, & Csizér, 2011), Ukraine (Henkel, 2010) and Indonesia (Lamb, 2011). Most studies focused on validation or examination of the

relationship among the components of the ideal L2 self and integrativeness. While some studies inquired the correlation among the three components of L2 Motivational Self System and other constructs such as anxiety and intended effort to learn English. The main finding of the research are (i) correlations between traditional Integrativeness and the Ideal L2 Self can indeed be equated; (ii) compared with integrativeness, the Ideal L2 Self serves a better job understanding motivated behaviour; (iii) traditional instrumentality can indeed be divided into two distinct types-instrumentality-promotion and instrumentality-prevention.

CONCLUSION

In this paper, the author firstly argued the necessity of reconceptualization of the 'integrativeness' in Gardner's model. As English is increasingly used as an international language of communication, learning English is no longer associated with the process of identification with native speakers of English which is used to be the significant motivating factor. Consequently, the author proved the argument by revisiting recent empirical research on L2 motivation. Finally, a major theoretical shift taken place within the field of L2 motivation research was discussed. It is argued that 'integrativeness' of L2 motivation should be reconceptualized from the self-perspective as in newly proposed Dörnyei's L2 Motivational Self System in current global context.

REFERENCE:

- [1] Chen, J. F., Warden, C. A., & Chang, H.-T. (2005). Motivators that do not motivate: The case of Chinese EFL learners and the influence of culture on motivation. *Tesol Quarterly*, 39(4), 609-633.
- [2] Crookes, G., & Schmidt, R. W. (1991). Motivation: Reopening the research agenda. *Language learning*, 41(4), 469-512.
- [3] Crystal, D. (2003). *English as a global language*: Cambridge University Press.
- [4] Csizér, K., & Kormos, J. (2009). Learning experiences, selves and motivated learning behaviour: A comparative analysis of structural models for Hungarian secondary and university learners of English. *Motivation, language identity and the L2 self*, 98-119.
- [5] Csizér, K., & Lukács, G. (2010). The comparative analysis of motivation, attitudes and selves: The case of English and German in Hungary. *System*, 38(1), 1-13.
- [6] Dörnyei, Z. (2005). *The psychology of the language learner: Individual differences in second language*: Mahwah, NJ: Lawrence Erlbaum.
- [7] Dörnyei, Z. (2009). The L2 motivational self system. In Z. Dörnyei and E. Ushioda (eds.), *Motivation, Language Identity and the L2 self* (pp. 9-42): Bristol: Multilingual Matters.

- [9] Dörnyei, Z. (2010). Researching motivation: From integrativeness to the ideal L2 self. *Introducing applied linguistics: Concepts and skills*, 3(5), 74-83.
- [10] Dörnyei, Z. (2011). *Teaching and researching motivation*: Edinburgh Gate England: Pearson Education.
- [11] Dörnyei, Z., Csizér, K., & Németh, N. (2006). *Motivation, language attitudes and globalisation: A Hungarian perspective*: Multilingual Matters.
- [12] Dörnyei, Z., Csizér, K., & Németh, N. (2006). Motivational dynamics, language attitudes and language globalization: a Hungarian perspective. *Clevedon, UK: Multilingual Matters*.
- [13] Gao, Y., Zhao, Y., Cheng, Y., & Zhou, Y. (2004). Motivation types of Chinese university undergraduates. *Asian Journal of English Language Teaching*, 14, 45-64.
- [14] Gardner, R. C. (1985). *Social psychology and second language learning: The role of attitudes and motivation*: London: Edward Arnold.
- [15] Gardner, R. C., & Lambert, W. E. (1972). Attitudes and Motivation in Second-Language Learning.
- [16] Gardner, R. C., & Smythe, P. C. (1975). Motivation and second-language acquisition. *Canadian Modern Language Review*, 31(3), 218-230.
- [17] Henkel, B. (2010). Ukrainian and English motivational self system of minority learners in Transcarpathia. *Working Papers in Language Pedagogy*, 4, 86-107.
- [18] Higgins, E. T. (1987). Self-discrepancy: a theory relating self and affect. *Psychological review*, 94(3), 319.
- [19] Irie, K. (2003). What do we know about the language learning motivation of university students in Japan? Some patterns in survey studies. *JALT JOURNAL*, 25(1), 86-100.
- [20] Jenkins, J. (2007). *English as a Lingua Franca: Attitude and Identity*: Oxford University Press.
- [21] Kimura, Y., Nakata, Y., & Okumura, T. (2001). Language learning motivation of EFL learners in Japan-A cross-sectional analysis of various learning milieus. *JALT JOURNAL*, 23(1), 47-68.
- [22] Kormos, J., Kiddle, T., & Csizér, K. (2011). Systems of goals, attitudes, and self-related beliefs in second-language-learning motivation. *Applied Linguistics*, 32(5), 495-516.
- [23] Lamb, M. (2004). Integrative motivation in a globalizing world *Systems*, 32, 3-19.
- [24] Lamb, M. (2011). A Matthew Effect in English language education in a developing country context.
- [25] Liu, M. (2007). Chinese students' motivation to learn English at the tertiary level. *Asian EFL Journal*, 9(1), 126-146.
- [26] MacIntyre, P. D., MacKinnon, S. P., & Clément, R. (2009). The baby, the bathwater, and the future of language learning motivation research. In Z. Dörnyei & E. Ushioda (Eds.), *Motivation, language identity and the L2 self* (pp. 43-65): Bristol: Multilingual Matters.
- [27] Markus, H., & Nurius, P. (1986). Possible selves. *American psychologist*, 41(9), 954.
- [28] Masgoret, A. M., & Gardner, R. C. (2003). Attitudes, motivation, and second language learning: a meta-analysis of studies conducted by Gardner and associates. *Language learning*, 53(1), 123-163.
- [29] Nakata, Y. (1995). New attitudes among Japanese learners of English. *Culture and communication*, 173-184.
- [30] Noels, K. A. (2003). Learning Spanish as a second language: Learners' orientations and perceptions of their teachers' communication style. *Language learning*, 53(S1), 97-136.
- [31] Papi, M. (2010). The L2 motivational self system, L2 anxiety, and motivated behavior: A structural equation modeling approach. *System*, 38(3), 467-479.
- [32] Ryan, S. (2009). Self and identity in L2 motivation in Japan: The ideal L2 self and Japanese learners of English. In Z. Dörnyei & E. Ushioda (Eds.), *Motivation, language identity and the L2 self* (pp. 120-143): Multilingual Matters, Clevedon.
- [33] Taguchi, T., Magid, M., & Papi, M. (2009). The L2 motivational self system among Japanese, Chinese and Iranian learners of English: A comparative study. In Z. Dörnyei & E. Ushioda (Eds.), *Motivation, language identity and the L2 self* (Vol. 36, pp. 66-97): Multilingual Matters, Clevedon.
- [34] Ushioda, E. (1996). *The role of motivation*: Authentik.
- [35] Ushioda, E. (2001). Ema Ushioda Trinity College Dublin, Ireland Language Learning At University: Exploring The Role Of Motivational Thinking. *Motivation and second language acquisition*, 23.
- [36] Ushioda, E., & Dörnyei, Z. (2009). Motivation, language identities and the L2 self: A theoretical overview. *Motivation, language identity and the L2 self*, 1-8.
- [37] Warden, C. A., & Lin, H. J. (2000). Existence of integrative motivation in an Asian EFL setting. *Foreign language annals*, 33(5), 535-545.
- [38] Yashima, T. (2000). Orientations and motivation in foreign language learning: A study of Japanese college students.
- [39] Yashima, T. (2002). Willingness to communicate in a second language: The Japanese EFL context. *The Modern Language Journal*, 86(1), 54-66.

Smart Pedagogy of Learning Technologies: Implementing TPACK in Design and Selection of Technologies for the Future Classroom

Bosede Iyade. Edwards^{*1,2}, Adrian David Cheok^{1,2,3}

¹Imagineering Institute, Iskandar Puteri, Malaysia

²City, University of London, Northampton Square, London. UK

³Universiti Teknologi Malaysia, Johor Bahru, Malaysia

*bosede@imagineeringinstitute.org

Abstract— Educational technologies have always been an essential part of the education process that supports the general process of teaching practice. Current technological developments suggest smarter, and more technology-oriented future classrooms, where learners expect to engage more and more with novel technologies. The role of instructors in these smart classrooms therefore continues to evolve, and increasingly demanding a shift in focus from tools, to the learning they should support. Teachers' skills must go beyond random selection of technologies for teaching, to deep understanding of how smart technologies integrate with pedagogies in content delivery to achieve effective learning. This is the 'smart pedagogies of learning technologies' or SPELT. In the technology-invaded classroom of the future, professional teachers must possess the knowledge of how the 3 classroom elements of content, pedagogy and technology interact to support smart instruction. This is captured in the technological, pedagogical and content knowledge (TPACK) framework. In this paper, we argue that teachers' selection and/or design of learning technologies must leverage on the TPACK framework. We discuss the significance of engaging TPACK, focusing on two important concepts: learner-centered, technology-based pedagogical approaches and those that explore the affordances of multi-sensory modalities. We describe how TPACK can be implemented by instructors who are not familiar with the concept, illustrating this with brief descriptions of two projects on 'education in the future classroom' where robotics and virtual reality technologies are respectively implemented using peer teaching and multi-sensory instruction to deliver science content. The novelty of our work lies in the practical demonstration of how the philosophical notion of TPACK can be leveraged in the design of learning technologies to support smart instruction, in line with global and emerging trends in education.

Keyword— Emerging Trends in Education; Future of Education; Human-Computer Interaction; Human-Robot Interaction; Learning technologies; Teacher-Robots

1 INTRODUCTION

EDUCATIONAL technologies have always been an essential part of the education process. They are meant to support the learning of content, application of technology skills, and the general process of teaching practice, with a focus on the learner. Within the transformed technological environment of the twenty-first century, the place and role of pedagogical science continues to evolve, and to occasion dramatic changes in the roles of players within the context of learning. It is further transforming the significance of concepts including the design of instruction and learning technologies. These changes are bringing learners more into their ideal roles as major stakeholders in the learning process and as being responsible for their own learning. However, the changes continue to place a demand for redefining education in terms of content, delivered by engaging the right technology and the appropriate pedagogy. All these must be integrated from the level of instructional design, and teachers/instructors must possess the required skills for the selection and implementation of classroom technologies within appropriate pedagogies for supporting content delivery. Engaging a standard framework that captures the interaction of the three classroom elements of content, pedagogy and technology in twenty-first century education therefore becomes an ideal approach to guide teachers.

The Technological, pedagogical and content knowledge (TPACK) framework is a standard framework for implementing educational technology. TPACK has been reported in many studies as an effective framework that captures the complex relationship between content, pedagogy and technology. Its significance in the smart education of twenty-first century, captured within practical design and implementation of classroom technology is however scarce. Engaging smart technologies within smart pedagogies for effectively delivering content is what we describe as the 'smart pedagogy of learning technologies', or SPELT, and represents the focus of this paper. We focus on the place of the TPACK framework in achieving this, with learners' interest as the central focus and the employment of pedagogies that explores the multiple advantages of novel technologies for delivering content effectively.

We focus on the engagement of learner-centered, technology-based pedagogies and those leveraging multi-sensory modalities as critical for effective instruction, based on the continual increase in the number of learning technologies supporting these possibilities and the proven ability of the techniques to promote effective instruction.

We address three specific objectives including a discussion of the significance of i) the concept of 'smart pedagogy of learning technologies'; ii) engaging TPACK within peer teaching iii) engaging TPACK within multi-

sensory instruction and iv) a demonstration of how we implemented this approach through brief descriptions of two projects focused on 'the future of education'. Our overall aim is to show not only how the philosophical notion of TPACK can be leveraged in the design and selection of learning technologies to support smart education, but also, how the 7 elements can be integrated and employed in the design of learning technologies for the future classroom. Our presentation and argumentation lies within the context of, and are based on, the concept of global and emerging trends in education, and the opportunities and challenges presented for sustainable learning.

The rest of this paper is divided into four sections, the section provides a review of the literature on key concepts captured in the work including the challenges of technology use within education, the TPACK framework, its components and significance, the concept of smart pedagogy of learning technologies, and the theoretical foundations of the two approaches focused in this work. In section 3, we describe how the concept of 'smart pedagogy of learning technologies' was implemented through TPACK in the development of two education applications including a robotic instructor system and a virtual reality classroom system. The last section provides a brief discussion of the theoretical and practical implications of our work for instructional designers and facilitators in the future 'classroom'. The paper ends with a summary, a conclusion and suggestion for future works.

2 LITERATURE REVIEW

This section provides a review of the literature on key concepts captured in the work including the challenges of technology use within education, the TPACK framework, its components and significance, the concept of smart pedagogy of learning technologies, and the theoretical foundations of the two approaches focused in this work.

2.1 Challenges of Technology Use with learning Contexts

Learning with technology is exemplified in many theories [1]-[4]. However, the rapid rate at which novel technologies make their appearance in current learning leaves no breathing space for instructor mastery. This is a major challenge with technology use within educational contexts. Software design is another challenge. Most tools are created as solutions to corporate business needs, rather than as solutions to pedagogical challenges, and are only adapted for classroom use. As such, design processes engage the viewpoint of programmers and developers, rather than those of instructors or instructional designers, and learners' interests are therefore not at the heart of most designs. These tools are usually context-neutral, and integrating them into learning assumes a uniformity in teacher personality, preferences, and ultimately, in engagement with technology. This presents serious challenges in learning, which is a contextual process. Addressing this requires some measure of proactiveness on the part of instructors, demonstrated in selection and design of learning technologies. Other issues include the emphasis on tools, rather than on how to use it to support learning. This is reflected in the presentation of a daunting variety of tools with no

standard plan for supporting teacher's engagement and mastery. Since instruction is not meant to be a trial-and-error procedure, the need for clear focus, based on a standard framework to support the concept of SPELT becomes critical.

2.2 The TPACK Framework

The technological, pedagogical, and content knowledge (TPACK) framework was informed by appropriate learning philosophies, and it has been described as a standard framework for the purpose of understanding the complex interaction between classroom elements. However, not much is available in practical terms on how TPACK can support SPELT by focusing on every step from conception through design to classroom implementation stages.

TPACK has a precursor in Shulman's pedagogical content knowledge (PCK) framework [2] which describes the complex relationship between content and pedagogy at a time when the current technological pervasiveness of human life, society and the classroom was not the norm. Though learning technologies have always been part of education, previous tools have been rendered transparent, that is, they have become so familiar that the 'tech' in the technology is no more obvious. In recent times, a range of novel digital technologies have found their way into the classroom and into educational discourse, placing a demand for mastery on instructors.

The TPACK framework builds on Shulman's, extending it to the phenomenon of teachers' integration of technology into pedagogy. It describes how teachers' understandings of the three classroom elements of technology, pedagogy, and content can interact to produce effective discipline-based and technology-aided instruction (AACTE, 2008). TPACK insists that the most effective form of learning with technology is based on a philosophy that the three elements do not exist as standalone concepts, but interact as pairs and as a whole. TPACK identifies 7 elements that include the interaction of these elements, capturing seven components including the 3 basic of content knowledge (CK), pedagogical knowledge (PK), and technological knowledge (TK). CK being knowledge about subject matter, while PK captures deep knowledge about the processes, practices or methods of teaching and learning, and how it encompasses, overall educational purposes, values, and aims. TK focuses on knowledge about traditional and more advanced, novel and emerging technologies including the skills required to operate particular technologies. The pairwise interaction of these elements yield 3 other elements including pedagogical content knowledge (PCK), technological content knowledge (TCK) and technological pedagogical knowledge (TPK) with TPACK as the interaction of all three elements making the seventh. Figure 1 shows the 7 elements of TPACK. PCK refers to knowledge of pedagogy that is applicable to the teaching of specific content, and includes knowing what teaching approaches fit a specific content, and how elements of the content can be arranged for better teaching.

TCK captures the manner in which technology and content are reciprocally related. Although technology constraints the kinds of representations possible, newer technologies often afford newer and more varied representations and greater flexibility.

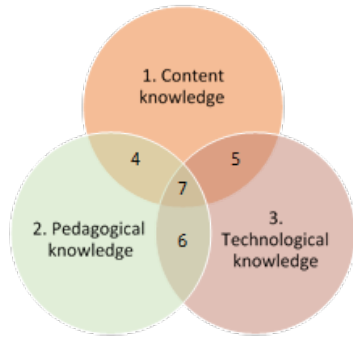

Figure 1: TPACK Framework showing the 7 Elements

Teachers need to know, not just the subject matter they teach, but also the manner in which the subject matter can be changed by the application of technology. TPK is the knowledge of the existence, components, and capabilities of various technologies as they are used in education, as well as how using particular technologies might impact the instructional process. TPACK brings together all these concepts and represents the form of knowledge that expert teachers should possess (whether this is obvious as with novel technologies or not, as with transparent technologies) and requires teachers to reconfigure their understanding of technology as well as of the three components.

Implementation of the TPACK framework has been reported in observation studies of faculty development and technology integration [3], [4] with emphasis on how TPACK informs and guides the integration of learner needs and characteristics as significant factors in the design of instruction. TPACK as an analytical tool has also been reported [5], with qualitative findings emphasizing the themes of technology, pedagogy, and content as co-dependent rather than independent constructs.

2.3 Theoretical Foundations of Peer Instruction

Peer Instruction (PI) has its foundation in active learning theories [9], [10]. Rusbult [11] describes learning situations that supports active learning to include learning from others, learning by discovery and learning by doing. He submits that, we learn most from others, with collaboration and communication being key to the learning process. We focus on a formal description of PI by Mazur [9], as a process whereby learners engage in knowledge sharing as a means of encouraging understanding, and improving learning through teaching others. It engages learners to share thoughts on a learning material based on personal understanding, and thereby benefit from peer as well as personal reviews [12]. Formal PI engages technology as a means of fostering motivation, engagement and deeper learning through students’ responses which are collected by various means. The effectiveness of peer instruction has been reported in various subjects [13]-[16].

Two relevant concepts in peer instruction, related to the concept of ‘pedagogy of learning technologies’ are the use of conceptual questions (ConceptTests or CTs), and ‘voting’ or student response, which leverages classroom response systems (CRSs). Voting is based on students’ choice of answers to the CTs. The place of technology is exemplified in the use of CRSs which in modern classrooms are hand-held electronic tools or digital platforms

which focus on promoting students’ interest, motivation and improved classroom atmosphere which increases engagement.

2.4 Theoretical Foundations of Multisensory Instruction

Information processing by humans is understood from diverse cognitive perspectives including schema [6], levels-of-processing [7], dual-coding [8], and stage [9] theories, addressing effective learning from various dimensions. The dual-coding theory recognizes multiple processing of information, but does not capture the whole extent of other possibilities with multisensory modalities. We argue for an extended idea of information processing involving multiple-coding beyond the visual and auditory senses. We specifically address ‘haptics’ or the sense of touch’ as a significant aspect of learner perception that begins early in life, and even prior to the extensive development of the auditory and visual senses.

3 SMART PEDAGOGY OF LEARNING TECHNOLOGIES (SPELT)

According to US Senator Nancy Kassebaum, the almost infinite uses to which computer and other novel technologies can be put are not as important as the ability of teachers to bring these into classroom practice [10]. This is the essence of the TPACK framework. We present here the process flow for implementing TPACK in addressing the specific tool-induced constraints on content, including the nature of possible representations which sometimes place undue constraints on instructional moves and other pedagogical decisions. The complex relationship of technological knowledge and pedagogical and content knowledge and how they integrate in the process of developing good teaching is what we refer to as the ‘smart pedagogy of learning technologies’ (SPELT).

Gibson [11] describes the ‘pedagogy of learning’ (PoL), a similar concept to PCK [2], and a contradiction intended to suggest a reduction of emphasis on the teaching process in favour of emphasis on learning. Gibson proposes a position whereby individual learner’s needs drive the instructional process. Similar to Gibson, through SPELT, we intend to suggest a reduction of emphasis on the exclusive place of technology in the teaching process, in favour of emphasis on the learning that it is intended to promote. SPELT is thus, a call to look away from trending tools, technologies, gadgets and the best pedagogical approaches, to focusing on learner’s needs and learning. We emphasize that ‘knowing how to use technology is not the same as knowing how to teach with it’. SPELT can guide system design and the creation of coherent learning environments. Following, we describe the development of two learning technologies in the context of smart classroom systems, and how SPELT is integrated using TPACK in their design. As we developed the teaching systems, we pursued the idea that the design of learning technologies should be driven by learners’ needs and the achievement of effective learning. We specifically focused on two approaches that have been emphasized in education, and which has persisted through the decades; these are peer

teaching, and multisensory instruction. We describe a robotic instructional system based on peer teaching and a virtual reality learning system based on multisensory instruction to illustrate our concept of SPELT.

4 TPACK FOR IMPLEMENTING SPELT IN THE DESIGN AND SELECTION OF LEARNING SYSTEMS

4.1 The Robotic Teacher System

Inspired by possibilities of non-human teachers in the smart classroom of the future, and based on capabilities already demonstrated by machines, and trends in artificial intelligence, robotics and internet accessibility our team developed a robotic instructional system that engages learners in the STEM classroom. In line with TPACK, the system was based on the PI pedagogical approach, thereby removing the focus from the 'teacher' to learners in the learning-by-teaching procedure. The system focuses on extending the role of technology beyond serving as tools, to playing roles that parallels that of humans in tomor-

row's classrooms while keeping the learner as the focus.

4.2 The Multisensory Classroom on VR (MCVR)

The MCVR integrates the advantages of immersive learning with audiovisual and tactile modalities in its design. We focused on the known effectiveness of e in the design of the system which is hosted in a VR environment on a PC or head mounted display (HMD) which enables the learning of structures of organic chemistry through a game-like procedure for building basic hydrocarbon molecules. Learners are enabled to pick atoms to build molecules based on game rules that are standard rules of structures in organic chemistry. In the process, participants learn 'what works' and what doesn't. By introducing the game-like approach, learners are motivated and engaged in the unconscious learning process. In addition, the procedure also enabled team or collaborative approaches to learning. The integration of TPACK approaches in the design of the two systems, highlighting the concept of SPELT, is shown in Table 1.

Table 1: Integration of TPACK Elements and SPELT in Learning System Design

	Knowledge Type and Description	Integrated TPACK Elements in the Learning Systems
1	Content Knowledge (CK): Knowledge of subject matter	Knowledge of basic science is the basis of instruction
2	Technological Knowledge (TK): addresses knowledge about standard, and emerging tools and the skills required to operate them	Focus on the robotics and VR; for supporting learner motivation, engagement, immersive and multisensory learning, and are adequate for science instruction
3	Pedagogical Knowledge (PK): Deep knowledge of the processes, practices or methods of teaching and learning & how it encompasses overall educational purposes	Selection of the learning-by-teaching approach with the robotic instructor and learning through immersion, and multisensory modalities in the VR system.
4	Technological Content Knowledge (TCK): the manner in which technology and content are reciprocally related; varied representations and flexibility, and how subject matter can be impacted by application of technology. For example, a 3D system will be appropriate for teaching spatial relationships or orientations.	Content for the robot system was based on simple introduction to matter, element and symbols while the VR system focus on the structure of molecules as combination of atoms. Though science contents are employed in both systems, specific content/topic were selected to match and maximize the affordance of the technology type
5	Pedagogical Content Knowledge (PCK): knowledge of pedagogy applicable to the teaching of specific content; of teaching approaches that fits a specific content, and how elements of the content can be arranged for better teaching	PI is not only ideal for promoting effective learning, it is also a learner-focused approach that is ideal for a non-human facilitator by making the learner play the role of instructor. A multisensory approach to the teaching of building organic molecules is equally an ideal approach
6	Technological Pedagogical Knowledge (TPK): Employing knowledge about technology in selecting and using appropriate pedagogy.	Our focus is to prioritize the learner in the learning procedure; in both systems, the knowledge of robotics and VR systems were brought to bear in selecting the pedagogical approaches and the content being communicated;
7	Technological Pedagogical Content Knowledge (TPACK): knowledge that expert teachers should possess	A holistic teacher knowledge or TPACK is demonstrated in how CK integrates with TK in the use of robotics or VR and PK of the learning-by-teaching and multisensory approaches for delivering science content

4.3 Theoretical and practical implications

The implications of SPELT for instructional designers and facilitators in the future 'classroom' are in theoretical and practical dimensions. The roles that machines and other non-human entities will play in the future classroom can only be imagined. As technological developments continue to be extensive, demands on teachers to upgrade their knowledge will increase and so will the type of skills required of them. The roles of teachers will become more and more that of classroom managers, facilitators of instruction, and co-designers of learning technologies. Skills

on selection of appropriate tools for supporting learning will also be in high demand. As co-learners in the future classroom, TPACK integrated in SPELT will serve as an ideal framework for effective teaching practice.

6 CONCLUSION

This paper focused on a demonstration of the important place of learning as the focus of technology use, pedagogical approaches and content development. We also highlight how the complex interaction between these elements

can be engaged by the professional teacher. We wish to note that technological trends and developments will continue to create educational challenges, hence, teachers must keep up-to-date, continuously learning and keeping abreast of global developments both in their fields and in the area of technology. The teachers' role will continue to evolve, placing a demand for skills and knowledge upgrade regarding novel technologies, content and pedagogical approaches ideal for different learning situations. We have augmented Gibson's [11] PoL with SPELT, and we hope that future research can also examine and expand the 'pedagogy of learning content' or 'pedagogy of subject matter' to complete the system.

REFERENCES

- [1] R. Gardner, "Introduction to debriefing," *Seminars in Perinatology*, vol. 37, no. 3, pp. 166-174, 2013.
- [2] J. Loughran, A. Berry, and P. Mulhall, "Pedagogical Content Knowledge," in *Understanding and Developing Science Teachers' Pedagogical Content Knowledge*, 2012, pp. 7-14.
- [3] M. J. Koehler, P. Mishra, K. Hershey, and L. Peruski, "With a Little Help From Your Students: A New Model for Faculty Development and Online Course Design," *J. Technol. Teach. Educ.*, vol. 12, no. 1, pp. 25-55, 2004.
- [4] P. Mishra and M. J. Koehler, "Technological pedagogical content knowledge: A framework for teacher knowledge," *Teachers College Record*, vol. 108, no. 6, pp. 1017-1054, 2006.
- [5] M. J. Koehler, P. Mishra, K. Yahya, and A. Yadav, "Successful Teaching with Technology: The Complex Interplay of Content, Pedagogy, and Technology," *la Soc. Inf. Technol. Teach. Educ. Int. Conf. SITE*, pp. 2347-2354, 2004.
- [6] V. E. Ghosh and A. Gilboa, "What is a memory schema? A historical perspective on current neuroscience literature," *Neuropsychologia*, vol. 53, no. 1, pp. 104-114, 2014.
- [7] R. S. Lockhart and F. I. M. Craik, "Levels of processing: A retrospective commentary on a framework for memory research," *Can. J. Psychol.*, vol. 44, no. 1, pp. 87-112, 1990.
- [8] J. M. Clark and A. Paivio, "Dual coding theory and education," *Educ. Psychol. Rev.*, vol. 3, no. 3, pp. 149-210, 1991.
- [9] F. I. M. Craik and R. S. Lockhart, "Levels of processing: A framework for memory research," *J. Verbal Learning Verbal Behav.*, vol. 11, no. 6, pp. 671-684, 1972.
- [10] U. S. Nancy Kassebaum, "Instructional Technology Literacy for Educators," *Wisconsin Department of Public Instruction*, 2018. [Online]. Available: <https://dpi.wi.gov/imt/instech>.
- [11] I. W. Gibson, "At the intersection of technology and pedagogy: Considering styles of learning and teaching," *J. Inf. Technol. Teach. Educ.*, vol. 10, no. 1-2, pp. 37-62, 2001.

Key Determinants of Contraceptive Use Among Married Women in North-Eastern Region of Nigeria

Itohan Owoloko^{1*} and Muiyiwa Oladosun

¹Covenant University Ota Ogun state, Nigeria

[*itowoloko@yahoo.co.uk](mailto:itowoloko@yahoo.co.uk)

Abstract— This paper examines the key determinants of contraceptive use in the North-Eastern part of Nigeria. It employed 5309 sub-sample of married women representing the North-East region of Nigeria from the 2013 nationally representative Nigeria Demographic and Health survey. It employed logistics regression statistical techniques in the analysis. Results present direct and indirect effects of predictors of contraceptive use. Predictors that had direct effects on contraceptive use were; state of residence, wealth status, number of living children, and told about family planning (FP) from health facility, while those with indirect effects were; education, religion, type of employment, husband/partner's education, heard about FP from TV last few months, and person who usually decides on household purchases, and person who decides on visit to family/relatives had joint direct effect (Nagelkerke R^2 , explained variation = 38%). The odds of contraceptive use varied significantly by state of residence, while the odds increased with; higher wealth status, among respondents told about FP at health facility, and decreased significantly among those who husbands/partner decides on respondent's visit to family/relative. These findings are crucial to policy and programs geared to increase contraceptive use in the north-east region of Nigeria.

Keywords – Contraceptive Use; Family Planning; Socio-Demographic; Decision Making

1. INTRODUCTION

Nigeria's population is well over 180 million [1] and total fertility rate is at a high of 5.5 while contraceptive use is about 15%. Although Nigeria's contraceptive use has been consistently low, the 2013 Nigeria Demographic and Health Survey (NDHS) shows that North-East Region has among the highest fertility rate (6.3) and the lowest contraceptive rate of 3% [2]. Persistent low contraceptive use and high fertility rate have negative impacts on quality of life. At the other side of the equation is poverty prevalence rate in Nigeria which is quite high, with estimate by the National Bureau of Statistics [3] of 61.2% with North-East region the hardest hit especially with the protracted insurgency and insecurity in the region.

Evidence suggest that parents with large family find it difficult to feed and educate their children which contribute to the high level of poverty in the country. Most women are poor and disadvantaged and most of the death recorded is caused by lack of access to proper health care [4]. In order to reduce poverty among the disadvantaged population especially in the North-East region where conditions of life have deteriorated considerably in recent times, it is necessary to provide evidence on how to promote family planning among households. With the aim of attaining smaller family size in the long-run thus, contributing to reducing challenges of sustainable future in the region.

Evidence suggest that socio-demographic variables such as age [5], place of residence [6], education [7,8,9], number of living children [7], and religion [10,11,12] have influence on contraceptive use. Other socio-demographic factors in the literature influencing contraceptive use include number of co-wives [13,14], work status [7], and husband's education [15,16,17,18].

Evidence also showed that exposure to FP information affects contraceptive use [19,20,21], and the dy-

namics of household decision making affects contraceptive use [22,10,23].

This study shed more insights on contraception dynamics in the North-East region of Nigeria by examining the relationships between contraceptive use and socio-demographic factors [24,25,26], effect of exposure to family planning information, household decision making and contraceptive use among married women in the region with a view to reducing fertility rate through evidence based support for family planning (FP) and contraceptive use behavior thus, contributing to achieving sustainable future espoused by SDG 3.7.

2. METHODS

2.1 Study Design & Description

This study used the National Demographic and Health Survey (NDHS) data of 2013. The Demographic and Health Surveys (DHS) are well established nationally representative studies carried out in about 100 countries all over the world, mostly in less developed countries. The DHS data includes information on population and health indicators used for planning, decision making, and policy in the countries.

The 2013 NDHS employed three-staged stratified sampling procedure. In the first stage localities were separated by rural and urban areas, and 893 localities were selected with probability proportion to size (PPS). In the second stage 904 enumeration areas (EAs) were selected with equal probability of selection, and an updated sampling frame of all households was implemented. In the third stage, 45 households were selected from each of the 904 EAs using equal probability systematic sampling technique. In total, 40,680 household were selected 16,740 urban, and 23,940 rural. All women aged 15-49 who were usual members of the selected household or who spent the night before the survey in the household were interviewed

[2].

This study used extracted sub-sample of 5309 married women living in the North-East region of Nigeria. Survey instruments were mostly similar to those of past surveys that have passed the test of validity and reliability. Survey instruments among others covered socio-demographic and economic variables including age, state of residence, place of residence, highest educational level, religion, wealth index, number of co-wives, type of employment, number of living children, and husband’s background factors i.e. age, education, and type of employment. Other variables employed in this paper were on exposure to family planning (FP) information, household decision making, and contraceptive use [3].

2.2 Model Specifications

Logistic regression model explaining the relationship between contraceptive use and predictors is presented below.

$$C = \beta_0 + \beta_1 X_1 + \beta_2 X_2 + \dots + \beta_n X_n + e, \quad n = 1, 2, 3, \dots, 12$$

where C is contraceptive use, β is the constant / intercept term, β_s are the regression coefficients suggesting strength of the relationship, X’s are the independent variables i.e. X₁ (age), X₂ (state of residence), X₃ (place of residence), X₄ (highest educational level), X₅ (religion), X₆ (wealth index), X₇ (Co-wives) X₈ (type of employment), X₉ (number of living children), X₁₀ (husbands age), X₁₁ (husbands’ education), X₁₂ (husbands type of work) X₁₃ (heard FP on radio), X₁₄ (heard FP on TV), X₁₅ (at health facility told about FP), X₁₆ (read about FP in a Poster), X₁₇ (person who decides on health care), X₁₇ (person who decides on large household purchases), X₁₈ (per son who decides on visit to family/relatives), and e is the error term.

Analysis included four models. Model I examined the direct relationships between contraceptive use and socio-demographic and economic variables, Model II examined direct relationships between contraceptive use and exposure to FP predictors, Model III examined the relationships between contraceptive use and household decision making factors, and Model IV teased out the direct and indirect relationships between contraceptive use and all predictors. Relationships were tested using three statistical significant levels, .05, .01, and .001.

3. RESULTS

3.1 Sample Description

Table 1: Percentage Frequency distribution of background factors

	Variable	Total (Total N = 5309)	Percent (%)
1	Age no Respondents		
	15-19	576	10.8
	20-24	971	18.3
	25-29	1089	20.5
	30-34	848	16.0
	35-39	763	14.4
	40+	1062	20.0
2	State of Residence		
	Yobe	912	17.2
	Borno	597	11.2
	Adamawa	804	15.1
	Taraba	1016	19.1
	Gombe	905	17.0
	Bauchi	1075	20.2
3	Place of Residence		
	Rural	4202	79.1
	Urban	1107	20.9
4	Women’s Education		
	No Education	3632	68.4
	Primary	848	16.0
	Secondary	649	12.2
	Higher	180	3.4
5	Religion		
	Islam – Trad	4366	82.5
	Catholic	138	2.6
	Other Christians	786	14.9
6	Wealth Index		
	Poorest	2082	39.2
	Poorer	1558	29.3
	Middle	837	15.8
	Richer	511	9.6
	Richest	321	6.0
7	Number of Co-Wives		
	No other wives	3051	57.7
	One or more	2239	42.3
8	Type of Employment		
	Not working	2389	45.6
	Informal	1282	24.5
	Formal	1570	30.0
9	No of Living Children		
	None	601	11.3
	1-2	1533	28.9
	3-4	1446	27.2
	5+	1730	32.6
10	Husband’s Age		
	34 or younger	1545	29.1
	35-49	2375	44.7
	50 or older	1389	26.2
11	Husband’s Education		
	No education	3099	58.7
	Primary	716	13.6
	Secondary	887	16.8

	Higher	579	11.0
	Husband's employment		
	Not working	39	0.7
	Informal	1319	24.8
	formal	3922	73.9

Table 1 above shows that 10.8% of the respondents were aged 15-19, 18.3% aged 20-24, 20.5% belonged to age group 25-29, 16% were in age group 30-34, 14.4% aged 35-39 and 20% of the respondents were in age group 40+. On state of residence, Bauchi state recorded the largest percentage of respondents (20.2%) followed by Taraba state (19.1%), and Yobe, Gombe, Adamawa and Borno followed with 17.2%, 17.0%, 15.1% and 11.2% respectively. The majority of respondents lived in the rural area (79.1%), while only (20.9%) lived in the urban area. About 68.4% of the respondents were uneducated while only 31.6% had formal education. Further breakdown along education level showed that 16.0%, 12.2% and 3.4% of the respondents had primary secondary and higher education respectively. The majority of respondents were Muslims (82.5%) and 17.5% were Christians. Also, Table 1 showed that the majority of respondents belonged to poorest/poorer wealth status (68.5%) while others may be classified as middle (15.8%), richer (9.6%) and richest (6.0%). Findings showed that 57.7% of the respondents were in a monogamous relationship while 42.3% were in a polygamous relationship. Also, 45.6% of the respondents were unemployed, 24.5% had informal jobs, while 30% had formal jobs. About 11.3% of the respondents had no living children, 28.9% had 1-2 living children, 27.2% had 3-4 living children while 32.6% of the respondents had 5 or more children.

3.2 Bivariate Results

Table 2: Showing bivariate association between contraceptive use and socio-demographic and economic factors, exposure to FP information, and household decision making factors

	Independent Variable N = 5309	Not using	Using
1	SOCIO-DEMOGRAPHIC & ECONOMIC		
	Age of Respondents (P-value = .000)		
	15-19		
	20-24	99.5	0.5
	25-29	98.0	2.0
	30-34	97.1	2.9
	35-39	95.5	4.5
	40+	93.3	6.7
		94.4	5.6
2	State of Residence (P-value = .000)	.000	
	Yobe	99.0	1.0
	Borno	97.8	2.2
	Adamawa	95.9	4.1
	Taraba	92.0	8.0
	Gombe	95.5	4.5
	Bauchi	97.7	2.3
3	Place of Residence (P-value = .000)		
	Rural	97.2	2.8

	Urban	92.2	7.8
4	Women's Education (P-value = .000)		
	No Education	98.5	1.5
	Primary	93.4	6.6
	Secondary/higher	88.8	11.2
5	Religion (P-value = .000)		
	Islam - Trad	97.8	2.2
	Christians	88.6	11.4
6	Wealth Index (P-value = .000)		
	Poorest	98.2	1.8
	Poorer	97.6	2.4
	Middle	96.2	3.8
	Richer	92.4	7.6
	Richest	82.9	17.1
7	Number of Co-Wives (P-value = .001)		
	No other wife	95.5	4.5
	One or more	97.2	2.8
8	Type of Employment (P-value = .000)		
	Not working	98.1	1.9
	Informal	94.4	5.6
	Formal	94.8	5.2
9	No of Living Children (P-value = .000)		
	1 or 2/None	98.2	1.8
	3-4	96.2	3.8
	5+	93.8	6.2
1	Husband's Age (P-value = .000)		
0	34 or younger	97.9	2.1
	35-49	95.1	4.9
	50 or older	96.1	3.9
1	Husband's Education (P-value = .000)		
1	No education	98.8	1.2
	Primary	94.6	5.4
	Secondary	95.2	4.8
	Higher	85.8	14.2
1	Husband's employment (P-value = .000)		
2	Informal/not working	98.1	1.9
	Formal	95.5	4.5
	EXPOSURE TO FP INFORMATION		
	Heard FP on radio last few months (P-value = .000)		
	No	97.3	2.7
	Yes	89.7	10.3
	Heard about FP on TV last few months (P-value = .000)		
	No	97.0	3.0
	Yes	84.5	15.5
	At health facility told about FP (P-value = .000)		
	No	95.2	4.8
	Yes	77.5	22.5
	Read about FP in a poster last few months (P-value = .000)		
	No	97.2	2.8
	Yes	87.2	12.8
	HOUSEHOLD DECISION MAKING		
	Person who usually decides on resp. health care (P-value = .000)		
	Else	93.7	6.3
	Husband-partner	97.2	2.8
	Person who usually decides on large household purchases (P-value = .000)		

Else	92.6	7.4
Husband-partner	97.2	3.0
Person who decides on visit to family relatives (P-value = .000)		
Else	94.8	5.2
Husband-partner	97.0	3.0

Table 2 above shows results of the association between contraceptive use and predictors. Socio-demographic and economic factors significantly associated with contraceptive use were, respondent's age (P-value = .000), state of residence (P-value = .000), place of residence (P-value = .000), education (P-value = .000), religion (P-value = .000), wealth status (P-value = .000), number of co-wives (P-value = .001), type of employment (P-value = .000), and number of living children (P-value = .000). Husband's key socio-demographic and economic factors significantly associated with contraceptive use were his age (P-value = .000), education (P-value = .000), and type of employment (P-value = .000).

Exposure to FP information variables significantly associated with contraceptive use were heard FP on radio in last few months (P-value = .000), heard about FP on TV in last few months (P-value = .000), at health facility told about FP (P-value = .000), and read about FP in a poster last few months (P-value = .000).

On household decision making, key variables significantly associated with contraceptive use were person who usually decides on respondent's health care (P-value = .000), person who usually decides on large household purchases (P-value = .000), and person who decides on visit to family relatives (P-value = .000).

3.3 Multivariate Results

The association between contraceptive use and independent variables established in section 3.2 above thus, suggest implicit relationship dynamics between contraceptive use and predictors which were further explored by multivariate analysis. Table 3 below shows the odds of married women using contraceptive in north-eastern Nigeria according to their socio-demographic, exposure to FP information, and household decision making factors.

The benchmark for interpreting odds ratios in this study is 1 such that odds ratios above 1 is termed more likely than the reference category, and values less than 1 is interpreted as less likely than the reference category. In order to identify the most important determinants of contraceptive use, and tease out direct and indirect relationships, Model I only examined the relationships between contraceptive use and socio-demographic factors, Model II examined the relationship between contraceptive use and exposure to FP information variables, while Module III was on the relationship between contraceptive use and household decision making indicators. Model IV is the full model representation the relationship between contraceptive use and all predictors with the aim of identifying the most important predictors.

Table 3: The Odds of Married Women Using Contraceptives by Predictors

	Variable	Model I		Model IV	
		Odds	Sig.*	Odds	Sig.
1	SOCIO-DEMOGRAPHIC				
	Age of Respondents				
	15-19 (ref)	1.00		1.00	
	20-24	2.91	.157	2.36	.437
	25-29	2.49	.232	1.08	.944
	30-34	3.14	.149	.841	.882
	35-39	4.34	.067	1.03	.982
	40+	4.31	.071	1.50	.736
2	State of Residence				
	Yobe	1.00		1.00	
	Borno	1.43	.464	1.97	.317
	Adamawa	1.95	.122	2.65	.106
	Taraba	4.60	.000	4.27	.017
	Gombe	4.02	.001	5.23	.008
	Bauchi	2.46	.036	7.54	.001
3	Place of Residence				
	Rural	1.00		1.00	
	Urban	1.30	.295	1.04	.921
4	Women's Education				
	No Education (ref.)	1.00		1.00	
	Primary	2.01	.003	1.57	.214
	Secondary/higher	2.38	.001	1.74	.176
5	Religion				
	Islam - Trad (ref.)	1.00		1.00	
	Christians	2.28	.000	1.93	.079
6	Wealth Index				
	Poorest (ref.)	1.00		1.00	
	Poorer	.801	.384	.924	.853
	Middle	1.31	.345	1.12	.812
	Richer	2.23	.015	1.28	.637
	Richest	4.28	.000	5.57	.006
7	Number of Co-Wives				
	No other wives (ref.)	1.00		1.00	
	One or more	1.01	.980	1.29	.403
8	Type of Employment				
	Not working (ref.)	1.00		1.00	
	Informal	1.75	.010	1.59	.195
	Formal	1.16	.514	1.28	.481
	No of Living Children				
	1 or 2/None (ref.)				
	3-4	1.00		1.00	
	5+	1.77	.024	3.18	.003
		3.61	.000	9.33	.000
	Husband's Age				
	34 or younger (ref.)	1.00		1.00	
	35-49	.800	.429	1.01	.980
	50 or older	.561	.101	.710	.533
	Husband's Education				
	No education (ref.)	1.00		1.00	
	Primary	1.76	.039	1.45	.387
	Secondary	1.09	.760	.778	.557
	Higher	2.29	.005	1.75	.208

Husband's employment Informal/Not working (ref.)	1.00		1.00	
Formal	1.38	.170	1.37	.372
Model I, Nagelkerke R ² = .275 = 28%				
EXPOSURE TO FP INFORMATION	Model II		Model IV	
	Odds	Sig.	Odds	Sig.
Heard about FP on radio No (ref.)	1.00		1.00	
Yes	1.27	.395	1.53	.230
Heard about FP on TV No (ref.)	1.00		1.00	
Yes	1.83	.043	1.54	.257
At health facility told about FP No (ref.)	1.00		1.00	
Yes	4.91	.000	4.10	.000
Read about FP on poster No (ref.)	1.00		1.00	
Yes	1.39	.217	1.39	.298
Model II, Nagelkerke R ² = .162 = 16%				
HOUSEHOLD DECISION MAKING	Model III		Model IV	
	Odds	Sig.	Odds	Sig.
Decision on health care Else (ref.)	1.00		1.00	
Joint decision	.661	.094	1.39	.381
Decision on large household purchases Else (ref.)	1.00		1.00	
Husband/partner alone	.434	.000	.571	.116
Decision on visit to family/relative Else (ref.)	1.00		1.00	
Husband/partner	1.20	.420	2.02	.041
Model IV, Nagelkerke R ² = .380 = 38%				

* = statistical significant levels i.e. .001, .01, .005

Logistics regression results in Model I, Table 3 showed that state of residence, respondent's educational level, religion, wealth status, type of employment, number of living children and husband's educational level had significant relationship with contraceptive use, and the odds were in the expected direction (explained variance = 28%). Results in Model II showed that indicators of exposure to FP information that had significant relationship with contraceptive use were; heard about FP on TV last few months before the survey and told about FP at health facility (explained variance = 16%). And when only household decision making variables were considered, the only significant factor was person who usually decides on large household purchases (explained variance = 3%).

In Model IV, all predictors of contraceptive use were factored into the equation to determine direct and indirect relationships. Results showed that only state of residence, wealth status, number of living children, and told about FP at health facility had direct relationships with contra-

ceptive use while wealth status was co-related with it. Predictors that had indirect relationships with contraceptive use were those that were significantly related in Models I, II, and III but were not significant in Model IV when all predictors were factored into the equation.

Model IV explained more variance (38%) in the relationship between contraceptive use and its determinants, including variables in the model and those not in the equation. Respondents in Bauchi state were over seven times more likely to use contraceptive than their counterparts in Yobe state, the reference category (P-value = .001). Respondents in Gombe state were five times more likely to use contraceptive than those in the reference category (P-value = .008), and respondents in Taraba state were four times more likely than the reference category to use contraceptive (P-value = .017). On wealth status, respondents in the richest category were over five times more likely than their counterpart in Yobe state to use contraceptive (p-value = .006).

Findings of this study showed that respondents who had more living children used contraceptive more than those who had none. Women who had five or more living children were nine time more likely than those who had none to use contraceptive (P-value = .000), and those who had three or four living children were three more likely than those who had none to use contraceptive (P-value = .003).

With respect to exposure to FP information, results showed that respondents who reported that they had about FP at health facility were four time more likely to use contraceptive than their counterpart who did not ($p = .000$). On household decision making, respondents were twice more likely to use contraceptive when husband/partner decided visit of respondent to family/relatives than the reference category (P-value = .041). This relationship was not significant in Model III when only household decision making variables were considered thus, suggesting that decision on visit to family/relative may be co-related with another variable in Model IV.

4 DISCUSSION & CONCLUSION

Although evidence in the literature showed that socio-demographic factors [25,26], exposure to FP information [27], and household decision making factors [10,28] have strong relationship with contraceptive use, this study corroborates these evidence, and provides additional information on the factors that have direct or indirect relationships with contraceptive use. Thus, suggesting which independent factors should come first in prioritizing strategies for program intervention.

In order to increase contraceptive use among married women in the north-east region of Nigeria where its use is considerably low, it will be necessary for policy and programs to be more strategic by categorizing factors influencing use into primary and secondary based on the strength of evidence provided by this study. In order to increase uptake of contraceptive use, socio-demographic factors that should be considered first are; state of residence, wealth status, and number of living children. It is not surprising to have state of residence as a key factor of

contraceptive use considering the ethnic differences across the states and by implication cultural differences as well. Also, wealth status role in accessing contraceptives is obvious considering transportation and monetary cost of obtaining a contraceptive method [29,30], while number of living children is adjudged a paramount factor in contraceptive use especially in developing countries [31]. Other socio-demographic factors that may be considered secondary based on evidence from this study are, education, religion, type of employment, and husband's education.

Another primary factor important to contraceptive use in the north-east region is access to FP information at health facility. It seemed that women had more trust in information obtained from health facility as they would treatment or antenatal services from professionals usually doctors [32, 33]. This factor need to be considered along with the significant primary socio-demographic factors mentioned above for maximum effects.

Other variables that had indirect effects on contraceptive use and are thus, classified under secondary influence were; exposure to FP information on TV, and person who decides on large household purchases. A factor termed as co-directly related with contraceptive use was person who decides on visit to family/relative. This factor is perhaps, strengthened by another factor since it was not significant in the reduced Model III. Policy and programming that considers these predictors prioritizing into primary and secondary will increase contraceptive use in the region.

ACKNOWLEDGMENT

We want thank the DHS Program for access to the data analyzed and to Covenant University for proving the necessary platform to do the study.

REFERENCES

- [1] Population Reference Bureau, (2014). World Population Bulletin, New York, www.pub.org.
- [2] National Population Commission (NPC) [Nigeria] and ICF International. Nigeria Demographic and Health Survey 2013, 2014. Abuja, Nigeria, and Rockville, Maryland, USA: NPC and ICF International.
- [3] National Bureau of Statistics (2013). Nigeria Demographic and Health Survey. Abuja, Nigeria: National Population Commission.
- [4] Igboekwe, F.C., Oladimeji, O., Oladimeji, K. E., Adeoye, I. A., Akpa, O. M., Lawson, L. (2014). Utilization of Modern Contraceptive Among Women of Child bearing Age in Resource Constraints Setting: Evidence from 2008 National Demographic and Health Survey in Nigeria. *Journal of Health Science*, 4(3), pp.72-78.
- [5] Asiimwe, J. B., Ndugga, P., Mushomi, J., Ntozi, J.P.M. (2014): Factors associated with modern contraceptive use among young and older women in Uganda: A comparative analysis. *BMC Public Health* 14: 926.
- [6] Akpotu, N.E. (2005). Education as a Correlative of Fertility Rate Among Families in Southern Nigeria. *The African Symposium: an online Journal of African Educational Research Network*, Vol. 5 No.2, pp 4-15.
- [7] Palamuleni, M.E. (2013). Socio-Economic and Demographic Factors Affecting Contraceptive Use in Malawi. *African Journal of Reproductive Health* 17(3): 91-104.
- [8] Kamal, Mostafa S.M. (2009). Contraceptive Use and Method Choice in Urban Slum of Bangladesh. *International Conference on Family Planning: Research and Best Practices*, 15-18 November 2009.
- [9] Cochrane, S.H. (1979). *Fertility and Education: What Do We Really Know?* The Johns Hopkins University Press, Baltimore and London.
- [10] Unumere G., Ishaku, S., Ahonsi, B., and Oginni, A. (2015). Contraceptive Use and its Socio-Economic Determinants among Women in North-East and North-West Region of Nigeria. *African Population Studies*, 29(2).
- [11] Bankole, A., and Singh, S. (1998). Couples' Fertility and Contraceptive Decision-Making in Developing Countries. *Hearing the main voice. International Perspective on Sexual and Reproductive Health*, 24(1).
- [12] Agadjanian, V. (2005). Reproductive Intentions and Contractive Choices in sub-Sahara fertility transition. *Population Research and Policy Reviews*, 24(6), pp 617-645.
- [13] Audu B., Yaya S., Geidama A., Abdusalami H., Takai I and Kyari O. (2008). Polygamy and the Use of Contraceptives. *International Journal of Gynecology and Obstetrics* 101(1), 88-92.
- [14] Nwakeze, N. (2010). Gender and Labor Force Participation in Nigeria: Issues and Prospects. *International Journal of Research in Arts and Social Sciences*, Vol 2, 2010, pp 477-492.
- [15] Nyauchi B. and Omedi, G. (2014): Determinants of unmet need for Family Planning Among Women in Rural Kenya. *Supplement on Demographic and Health Surveys in Africa*, 28(2).
- [16] Isiugo-Abanihe, U.C. (1994). Reproductive Motivation and Family Size Preferences Among Nigerian Men. *Studies in Family Planning* 25(3), pp 149-161.
- [17] Omondi O. (1997). Men's participation in family planning decision in Kenya. *Population Investigation Committee*, 51(1).
- [18] Kamal, M.S.M., and Hassan, H.C. (2013). Socioeconomic Correlates of Contraceptive Use among the Ethnic Tribal Women of Bangladesh: Does Sex Preference Matter? *Journal of Family and Reproductive Health*, 7 (2), June.
- [19] Mohammed, S. (2001). Personal Communication Network and the Effect of Entertainment Education Radio Soap Opera in Tanzania. *Journal of Health Communication*, 6(2), 137-154.
- [20] Westoff, C.F., and Rodriguez, G. (1995). The Mass Media and Family Planning in Kenya. *International Family Planning Perspectives*. 21(1):31-36.
- [21] Piotrow, P.T., Rimoh, J.G., Winnard, K., Kincaid, D.L., Huntington, D., and Convisser, J (1990). Mass Media Family Promotion in Three Nigeria Cities. *Studies in Family Planning* 21(5), 265-274.
- [22] Undelikwo, V.A., Osonwa, O.K., Ushie, M.A., and Osonwa, R.H. (2013). Family Planning Behaviours and Decision-making Among Couples in Cross River State, Nigeria. *International Journal of Learning and Development*

- opment, Vol 3, No. 1.
- [23] Bamikale, J.P. (2000). Spousal Communication and Contraceptive use among the Yoruba in Nigeria. *Population Research and Policy Review*, 19: 29-45.
- [24] Akinyemi, A., Adedini, S., Hounton, S., Akinlo, A., Adedeji, O., Adonri, O., ... Barros, A. J. D. (2015). Contraceptive use and distribution of high-risk births in Nigeria: a sub-national analysis. *Global Health Action*, 8,10.3402/gha.v8.29745. <http://doi.org/10.3402/gha.v8.29745>.
- [25] Adebowale (2013). Contraceptive use among Nigeria Women with no fertility infections: Interaction amid potential causative factors. *African Population Studies*, 27(2).
- [26] Orubuloye and Caldwell (1992). Fertility Decline in Africa: A new type of transition. *Population and Development Review*, 18(2).
- [27] Odimegwu, C.O. (1999). Family Planning Attitudes and Use in Nigeria. A Factor Analysis. *International family planning perspectives*, 25(2), pp. 86-91.
- [28] Makinwa-Adebusoye and Katz, M. (1997). Reproductive Decision-making in Nigeria. *Africa Population Studies*, 12(1), pp 89-108.
- [29] Adebowale AS, Gbadebo B and Afolabi FR. (2016) Wealth index, empowerment and modern contraceptive use among married women in Nigeria: are they interrelated? *J Public Health*. 24:415. 15.
- [30] Adebowale SA, Adedini SA, Ibisomi LD and Palamuleni ME. (2014) Differential effect of wealth quintile on modern contraceptive use and fertility: evidence from Malawian women. *BMC Women's Health*. 14:40.
- [31] Bankole, A. and Audam, S. 2011. Fertility preferences and contraceptive use among couples in sub-Saharan Africa. *African Population Studies*. 25 (2): 556-578.
- [32] Oladosun, M. 2016. Report on Qualitative Assessment of Community Knowledge, Perceptions, Practices, and Barriers to Malaria Prevention Services for Pregnant women in Zamfara and Kebbi States, Nigeria. FHI360 and USAID/Nigeria.
- [33] Humid, S. and Stephenson, R. 2006. Provider and Health Facility Influences on Contraceptive Adoption in Urban Pakistan. *International Family Planning Perspectives*. 32 (2): 71-78.

Relationship Between Parents' Socio-Economic Background, Parental Involvement and Students' Academic Performance in Higher Institutions of Learning in Adamawa State, Nigeria

Husseina Maryam Barkindo^{1,1}, Isma'ila Y. Shehu^{2,2*} and Aliyu M.M.³

¹Department of Vocational Education, Modibbo Adama University of Technology Yola

²Department of Vocational and Technology Education, Abubakar Tafawa Balewa University, Bauchi

*iyshehu@gmail.com

Abstract— *The main objective of this study was to determine the relationship between parents' socio-economic background, parental involvement and the students' academic performance in higher institutions of learning in Adamawa state. The study used correlational survey research design. The population of the study consisted of all 649 final year 2016/2017 business education students in higher institutions of Adamawa state while the sample size of the study was two hundred and sixteen (216) students drawn using proportionate random sampling technique. The instrument for data collection was a questionnaire titled "Influence of Parent's on Academic Performance Determination Questionnaire (IPAPDQ)". The data collected were analyzed using mean and standard deviation and simple correlations. The findings of the study among others revealed that socio-economic background of parents relates with students' academic performance in higher institutions of Adamawa State. The study also revealed that there was no significant relationship between parental involvement in the educational pursuit and business education students' academic performance in higher institutions of Adamawa state. It was recommended that parents, irrespective of their tight schedule should endeavor to be more involve in the educational pursuit of their children either financially or morally.*

Keywords: *Parent's Socio-Economic Background, Parental Involvement, Business Education, Academic Performance*

1. INTRODUCTION

Parents by virtue of their position at homes, families and society play a greater role on the lifestyle and behaviors of the younger generation [1]. As a result, their attitudes and how they relate with their children at home determine the level at which they are involve in the upbringing and performance of their child or children [2]. More so, parents exert greater influence on the children's decision as to who to associate with or not, what course to study at school, what career to pursue and even what type of person to marry or not for their future prospects. In an implied sense, parents influence their children by their own admiration for education and acquisition of knowledge, the zeal and interest in their respective occupation, the type of associates they move with and even the type of messages they want to hear. Parents, therefore tend to modify the behavior, taste and preferences of their children.

However, parents' socio-economic background such as their language, culture, religion and educational level attained provide a motivational factor on how far their children can go in the educational ladder. [3] highlighted that parents with more than minimum level of education are expected to have a favored attitude to their children's education and to encourage and help them with school-work. However, parent with low level of education may

not feel capable of assisting their child home exercises or play a role in his academic life as they may not understand the material to guide them with [4]. Parent's socio-economic status which is usually a reflection of their profession, vocation or trade makes significant impact on the academic pursuits of their children [5]. In addition to the above [6] stated that parental income is a cogent factor upon which the academic and vocational successes of secondary school students' life depends. A child that is deprived of the essential needs is likely to perform poorly in his school work.

The cry of many Nigerians on the falling standard of education and no one can say empirically that the Nigerian standard of education has 'risen' since then. Sincerely, speaking the standard of education is getting worse. This has been corroborated by [7] who asserts that students' poor academic performance is gradually becoming a norm in secondary and tertiary institutions in Nigeria. More so, judging from the previous academic performances of business education students in Adamawa state, their academic reports have indicated that high academic achievements have become a herculean task to attain among them as less than 5% of the students could graduate with a first class honor. [8] noted that the poor performances of business education students have affected the attainment of the objective for the provision of competent business education teachers at the secondary school level in the state. The extent to which these factors are responsible for poor aca-

ademic performance has, however, not been clear. In consequence, this study therefore seeks to determine the influence of parents on business education students' academic performance in higher institutions of learning in Adamawa State.

1. OBJECTIVES OF THE STUDY

The main objectives of this study was to determine the influence of parents' attitude and environment on academic performance of business education students in higher institution of learning in Adamawa state. Specifically, the study sought to:

- a) Determine socio-economic background of business education students' parents in higher institutions of learning in Adamawa State.
- b) Determine the extent of parental involvement in the educational pursuit of business education students in higher institutions of learning in Adamawa State.
- c) Determine academic Performance of business education students in higher institutions of learning in Adamawa State.
- d) Determine the relationship between socio-economic background of business education students' parents and their academic Performance in higher institutions of learning in Adamawa State.
- e) Determine the relationship between parental involvement in the educational pursuit of business education students and their academic Performance in higher institutions of learning in Adamawa State.

2. METHODOLOGY

The research design used for this study was correlational survey design. The design provides an opportunity for the researcher to predict scores and explain the relationship among variables [9]. The population of this study comprised of all the 649 final year 2015/2016 business education students in the higher institutions of Adamawa state. The sample of this study was given as 216 students out of the total population of 649 final year business education students in Adamawa state. Stratified random sampling was used to divide each school's population into a stratum and proportionately draw out from each stratum to form the sample of the study. The instrument used for data collection in this study was a questionnaire. The questionnaire was titled "Influence of Parents on Academic Performance Determination Questionnaire (IPAPDQ)" and used for eliciting information from final year students of business education in Adamawa state higher institutions. Documents (specifically the academic records of the students) from the academic offices of the various departments, showing the 2015/2016 End of Semester results and Cumulative Grade Point Average (CGPA) of final year students was collected, in order to derive the mean scores for

academic performance [10]. The data collected was analyzed using mean and standard deviation for research questions and z test was used to test the hypothesis at 0.05 level of significance.

4. RESULTS

4.1 Socio-economic background of business education students' parents in higher institutions of learning in Adamawa State

Table 1 below showed that out of 6 items of parents' socio-economic background, respondents agreed with all the items in the table and more emphasis was given to 1, where the respondents strongly agreed with it. With an average mean of 4.15 and standard deviation, the table revealed that socio-economic background of parents of business education students' contributes in improving students' academic performance in higher institutions of Adamawa State.

Table 1: Socio-Economic Background of Parents of Business Education Students

S/N	ITEMS	N	Mean	SD	Rmk
1.	Parent's Religion	195	4.60	0.77	SA
2.	Parents' Culture	191	4.14	0.72	A
3.	Parents' Language	199	4.20	0.84	A
4.	Parents' Health Status	202	4.04	0.85	A
5.	Parental Style of Upbringing	206	3.89	1.01	A
6.	Parents' Economic Class	188	4.03	1.04	A
	Average	199	4.15	0.88	A

Key: S.D = N = Number; Standard Deviation; SA = Strongly Agree; A = Agree; RMK = Remark

4.2 Extent of parental involvement in the educational pursuit of business education students in higher institutions of learning in Adamawa State

Table 2 below showed that all the respondents agreed with all the items on parental involvement. With an average mean of 3.97 and standard deviation of 0.93, the table revealed that the extent to which parental involvement contributes to business education students' academic performance was high in higher institutions of learning Adamawa State.

Table 2: Parental involvement in the educational pursuit of business education students

S/N	ITEMS	N	Mean	SD	Rmk
1.	Payment of School Fees	197	3.83	0.91	A
2.	Purchase of aca-	199	3.97	0.9	A

	demic materials like school bags, handouts, textbooks etc			1	
3.	Assistance towards school assignment	198	4.01	0.93	A
4.	Encouraging you to read	200	3.97	0.92	A
5.	Reaction towards your test and examination Scores	203	4.05	0.95	A
6.	General concern for your progress in school	199	3.94	0.97	A
	Average	197	3.97	0.93	A

Key: S.D = N = Number; Standard Deviation; A = Agree; RMK = Remark

4.3 Academic Performance of business education students in higher institutions of learning in Adamawa State

Table 3 shows grades and descriptive statistics of students' academic performance in higher institutions of learning in Adamawa State. The scores of results ranged from a minimum of 0.93 to maximum of 4.78 scores. The result revealed that only 5 students obtained grade A result; 52 obtained grade B result; 97 grade C; 52 grade D and 10 grade E. However, an average mean of 2.97 and standard deviation of 0.23 indicates the academic performance of the majority of students was within the lower grade level, generally falls within the range of grade C to E. This implies that getting grade A and B was a very difficult task to majority of business education students in higher institutions of learning.

Table 3: Academic Performance of business education students

S/N	ITEMS	N	Mi n	Ma x	Mea n	SD
1.	Grade A (70% and above)	5	4.54	4.78	4.63	0.11
2.	Grade B (60 – 69%)	52	3.50	4.46	3.96	0.28
3.	Grade C (50 – 59%)	97	2.40	3.49	2.94	0.31
4.	Grade D (45 – 49%)	52	1.55	2.38	2.04	0.25
5.	Grade E (40 – 44%)	10	0.93	1.49	1.29	0.19
	Average				2.97	0.23

Key: N = Number; S.D = Standard Deviation;

4.4 Relationship between socio-economic background of business education students' parents and their academic Performance in higher institutions of learning in Adamawa State

Table 4 shows the simple correlation (r) between business education students' academic performance and their parents' socio economic background. The results revealed that only two items have a positive statistically significant relationship with the students' academic performance in the institutions. These items include Parents' Language (0.03*) and Parents' Economic Class (0.03*). This implies that language and economic capacity of parents plays greater role improving students' academic performance.

Table 4: Correlations between socio-economic background of business education students' parents and their academic Performance

S/N	ITEMS	Corr.	Sig
1.	Parent's Religion	0.13	0.07
2.	Parents' Culture	0.11	0.50
3.	Parents' Language	0.16	0.03*
4.	Parents' Health Status	0.08	0.28
5.	Parental Style of Up-bringing	0.07	0.35
6.	Parents' Economic Class	0.16	0.03*

*P< 0.05

4.5 Relationship between parental involvement in the educational pursuit of business education students and their academic Performance in higher institutions of learning in Adamawa State

Table 5, shows the simple correlation (r) between business education students' academic performance and their parental involvement in the educational pursuit in higher institutions of learning in Adamawa State. Analysis of the items revealed that statistically significant relationship does had not existed between business education students' academic performance and their parental involvement in the educational pursuit in higher institutions of learning in Adamawa State. This implies that parents do not usually care much to know the progress of their children in acadmic activities.

Table 5: Correlations between parental involvement in the educational pursuit of business education students and their academic Performance

S/N	ITEMS	Corr	Sig
1.	Payment of School Fees	0.02	0.76
2.	Purchase of academic materials like school bags, handouts, textbooks etc	0.05	0.05
3.	Assistance towards school assignment	0.07	0.38
4.	Encouraging you to read	0.07	0.34

5.	Reaction towards your test and examination scores	0.07	0.34
6.	General concern for your progress in school	0.06	0.38

*P < 0.05

5. DISCUSSION

The findings of this study revealed that bivariate correlation between socio-economic background of parents influences business education students' academic performance in higher institutions of Adamawa State revealed that parents' language, parents' economic and academic performance that significant association existed. This further emphasized the need of including mother tongue in the training of vocational education students in Nigeria. This finding concurred with [11] [12] [13] finding that parental backgrounds, parental economic status, parental marital status and parental home location have an influence on a child's academic performance. Although, the findings disagree with that of [14] and [15] who found out that there is no much difference between the academic performance of students who have rich parent and that of students who are from poor parents. As there was a significant relationship between parents' socio-economic background and business education students' academic performance in higher institution of Adamawa state.

Also the finding of study showed that bivariate correlation between the items revealed that statistically significant relationship had not existed between the between business education students' academic performance and their parental involvement in the educational pursuit in higher institutions of learning in Adamawa State. This supported the finding of [13] and [16] who founded that there is always a tendency of improvement when parents involve themselves in their children's academics activities. Although, this contradicted the findings of [15] and [14] who found out that home factors do not really measure up to a students' academic performance in terms of students who have other guides aside from their parents.

7. CONCLUSION AND RECOMMENDATION

Based on the findings of this study, it was concluded that parental attitude (i.e. parents' socio-economic background and parental level of involvement) influence business education students' academic performance in higher institutions of Adamawa state. The following recommendations were also made;

- Parents should be fully made aware that their socio-economic background has an influence on their children's academic achievement in school.
- That, parents irrespective of their tight schedule should endeavor to be more involve in the educational pursuit of their children either financially or morally.

REFERENCES

[1] A. H. Abdulmalik (2013). *Issues militating against business education students' performances in colleges of education*. Unpublished manuscript.

[2] O.B. Akande (2007). *Socio-economic factors influencing students' academic performance in Nigeria*. Retrieved from <http://www.The free library>.

[3] O. O Akinsanya., K. O. Ajayi & M. O. Salami (2011). Relative effects of parental occupation, qualification and academic motivation of wards on students' achievement in senior secondary school mathematics in Ogun State. *British Journal of Arts and Social Science*, 3(2), pp. 242 - 252.

[4] J. J. Escarce (2003). Socioeconomic status and the fates of adolescents. Retrieved from <http://www.pubmedcentral.nih.gov/articlerender.fcgi?artid>

[5] N. E. Hill, D. R. Castellino, J. E. Lansford, P. Nowlin, K. A. Dodge, J. E. Bates, & G. S. Pettit (2002). Parents' academic involvement as related to school behavior, achievement, and aspirations: Demographic variations across adolescence. *Journal of child development*, 7(5), pp. 1491 – 1509.

[6] O. A. Jenbiyi (2011). Teacher quantity and student academic achievement in college of education in Nigeria; *Journal of Educational and Social Research*. 4 (3) pp. 38 – 51.

[7] C. Kudzai & N. Narainsamy (2014). Influence of home based factors on the academic performance of girl learners from poverty stricken families: A Case of Zimbabwe. *Mediterranean Journal of Social Sciences* 5 (6), pp. 223 – 232. doi: 10.5901/mjss. 2014.v5n6p223.

[8] C. H. Machebe & C. O. Ifelunmi (2014). Influence of parental socio-economic status on academic achievement of students in selected schools in Nigeria: A case study of Enugu State. *Journal of Education and Practice* 5 (2), pp. 105 – 110.

[9] M.Muruwei (2011). *Parents' level of education and senior secondary students' academic performance in English language in Bayelsa State, Nigeria*. Retrieved from <http://www.ajol/journal/jorind>.

[10] C. B. Musgrave (2000). Environmental factors affecting attitude towards science and Mathematics. *Journal of Educational Psychology*, 91 (1), pp. 382 – 394.

[11] Noah, A. O. K. & Aromolaran, A. B. (2015). Parents' attitude towards academic performance of their children: Implications for societal development. *International Journal of Research in Humanities and Social Studies*. 2 (1), pp. 22 – 27.

[12] M. I. Ogbemudia & M. V. Alasa (2013). Influence of home environment on the academic performance of primary five pupils' in English language in Orhionmwon local government area of Edo State. *Merit Research Journal of Education and Review*, 1 (5), pp. 120

- 125.
- [13] E. O. Onijingin., F. B. Alokun, & E. O. Osakinle, (2013). The influence of parents' educational background and study facilities on academic performance among secondary school students in Ondo State. *Ocean Journal of Social Sciences*, 6 (2), pp. 78 – 89.
- [14] C. Orlu, (2013). Environmental influence on academic performance of secondary school students in Port Harcourt local government area of Rivers State. *Journal of Economics and Sustainable Development*, 4(12), pp. 73 - 81.
- [15] F. N.Z. Siew, Z. Razimi, M. L. See. & J. C. Gary, (2016). A study of time uses and academic achievement among secondary school students in the state of Kelantan, Malaysia. *International Journal of Adolescence and Youth*. 21 (4), pp. 433 – 448.
- [16] W. Cresswell, (2012). Educational research: planning, conducting and evaluating quantitative and qualitative research. New Jersey: Pearson Education Inc.

BUILT ENVIRONMENT, EARTH AND ENVIRONMENTAL SCIENCES

Analysis of Trend and Dynamics of Urban Sprawl in Minna Niger State Nigeria

Muhammad N. Daniyan*, Mairo Muhammed

The Federal University of Technology Minna Geography Department

*daniyannasir@gmail.com

Abstract—Urban Sprawl in Minna is a phenomenon that is quite pronounced with many unsustainable impacts, consequently raising concern for environmental sustainability. This research evaluates Urban Sprawl dynamics in terms of its magnitude, direction and nature of occurrence by integrating Remote Sensing, GIS tools and Shannon's Entropy. The Landsat images of the study area acquired for the years 1990, 2000, 2010 and 2017 were processed and classified, the result shows that land use land cover is rapidly being transformed into built up area. The images were further divided into concentric buffer zones easily adoptable by relative Shannon's entropy, due to its high flexibility and the fact that it is unrestricted by the number of divisions used, the relative Shannon's entropy was calculated, It revealed that in 1990 and 2000 urban sprawl has low magnitude with compact form of settlement, while in the year 2010 and 2017 it became evenly dispersed with higher magnitudes and directed towards the south-western part of the study area, it shows that urban sprawl had always increased in its rates of dispersal throughout the period of the study, it is gradually becoming compact, as indicated by changes in its pattern from 2010 to 2017, showing increasing signs of environmental problems and decaying urban infrastructure. This research provides information about the pattern of urban sprawl which will help environmental managers in decision making. It is recommended that the rate of urban sprawl and increasing environmental decay should be matched with proportionate economic growth and environmentally friendly development practices.

Keyword—Environment, GIS, Relative Shannon's Entropy, Remote Sensing, Urbanization.

2 INTRODUCTION

Urbanization is a "process of human agglomeration in multi-functional settlement of relatively substantial size" (Jiboye, 2011). According to Ujoh, Kwabe and Ifatimehin, (2010), it is the process that refers to the growth both in size and numbers of urban centre. This process is responsible for the transformation of towns, cities and metropolitan areas, while at the same time increasing the process of direct rural-urban migration.

Increased population growth has led to massive urbanization and concentration of socioeconomic and physical activity, resulting in the creation of environmental issues and concentrate problems and vulnerabilities (Dawson, *et al.*, 2014).

Urbanization has become not only a manifestation but also an engine of change on how humans use and view the environment, Nigerian Cities are witnessing high rate of environmental deterioration and are rated among urban areas with the lowest livability index in the world (Adedeji and Eziyi, 2010), this is due to attempt by Nigerians to adjust their seemingly endless wants and desire for food, shelter, recreation, transportation, infrastructural facilities and so on to the land and other environmental resources available to them, as a result Urban infrastructures such as roads/streets, housing, electricity, water supply and waste management systems are depreciating and this has compounded the way the cities are sprawling.

In Minna urban sprawl is exceptionally rapid, such rapid urban growth has had many unsustainable impacts, it has consumed significant amounts of resources, produced waste, pollution and degrades the environment in the form of loss of agricultural land, green spaces and natural land, increased energy consumption and therefore, greater environmental pollution. Increased need for more infra-

structure like water, electricity, roads and health care facilities, the degradation of peri-urban ecosystems and valuable habitats within the city. It has lead also to increased traffic and high automobile dependency, as a result exacerbates global warming.

Currently these problems are major urban challenges in Minna, consequently raising the point that the cost of sprawl is borne by all of us not just those creating it. This opens up the field to investigate and understand its dynamics, with the aim of evaluating the trend and dynamics of urban sprawl in Minna.

1.1 Objectives

- To analyze Land use Land cover trend in Minna from 1990-2017.
- To Evaluate urban sprawl dynamics in Minna from 1990-2017.

1.2 Study Area

The study area is located about 150 kilometers from Abuja the Federal Capital Territory of Nigeria; Minna lies between latitudes 9°24'N- 9°48'N and longitude 6°25'E - 6°45'E, it is the State capital of Niger state (figure 1). It has a total population of approximately 506,113 with an average population density of about 3448 persons per km² (NISEPA, 2009). The population growth in the city is among the highest in the country and faster than the national average because of its proximity to the Federal Capital Abuja, it is occupying a land area of about 6,789 square kilometers and lies on a geological base of undifferentiated basement complex of mainly gneiss and magnetite (NISEPA, 2009).

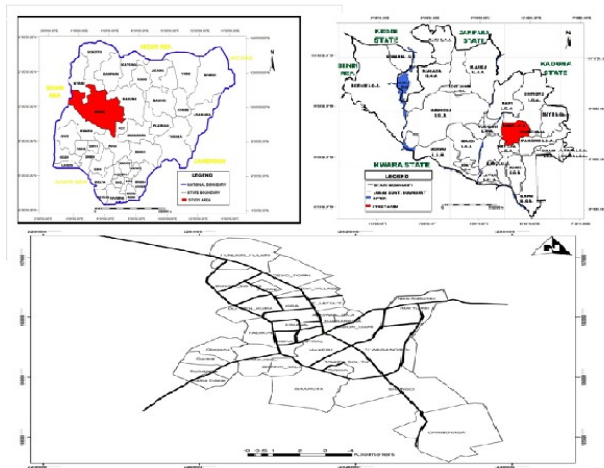

Figure 1: The location of the Study area
Source: Niger State Geographical Information System

2 METHODOLOGY

The data sets utilized were Landsat images of the study area for the years 1990, 2000, 2010 and 2017. The Landsat Images were acquired and classified as secondary data with their characteristics presented in table 1.

Table 1: Details of secondary data used and their characteristics

Data	Bands	Date	Resolution	Path/Row
Landsat TM	7 Bands	1990	30M	189/053 1990
Landsat ETM+	7 Bands	2000	30M	189/053 2001
Landsat ETM+	7 Bands	2010	30M	189/053 2011
Landsat OLI/TIRS	10 Bands	2017	30M	189/053 2017

2.1 The analysis of Land use Land cover trend in Minna from 1990 to 2017.

The rate of Land use Land cover (LULC) change in Minna between 1990 and 2017 was analyzed at a decade interval, the four landsat images were preprocessed and classified. The spectral bands of the images were stacked and masked in Erdas imagine 9.0 and ARC-GIS 10.3 environment. Supervised raster classification was carried using training samples obtained from the field, with maximum likelihood algorithm in the ARC-GIS environment to identify the homogenous groups of pixels, which represent various land use classes of interest; this was verified with a ground truth of the area. The land use were classified into four; Built up area, Bare-ground, Water and Vegetation which were computed and presented in a graph.

2.2 Urban Sprawl Dynamics in Minna 1990-2017

In other to evaluate urban sprawl dynamics in Minna, the classified landsat images were divided into concentric circles as buffer zones, from a point about the center of the

study area as employed by Srimanta, *et al* (2013), the approach used in this research involves the division of the study area into 15 zones, which is easily adoptable by the model used (relative Shannon’s entropy), due to its high flexibility on how the study area is divided and the fact that it is unrestricted by the number of divisions used.

The major variables are relative entropy (En) as well as change in relative entropy, which were calculated using equation one (1) and three (3) respectively with the results presented in graphs, the value for relative entropy ranges from zero (0) to one (1), where a value of one indicates even dispersal of the variable and a value of zero (0) indicates minimal dispersion (compactness), half way between zero (0) and one (1) is used as a threshold to determine whether the variable can be described as moderately dispersed or concentrated, the relative entropy was calculated using the formula given by Pedro *et. al.* (2013)

$$En = \sum_{i=1}^n P_i \log\left(\frac{1}{P_i}\right) / \log(n) \tag{1}$$

Where n= 15 which is the number of zones

$$P_i = \frac{X_i}{\sum X_i} \tag{2}$$

Where P_i = the density of land development, X_i = built up land in ith zone and $\sum X_i$ = total amount of land in ith Zone.

Change in relative entropy between two time periods indicate the magnitude, direction and nature of urban sprawl occurrence between the time periods. Therefore, changes in relative entropy values were calculated by subtracting the relative entropy value of the base year from that of the terminal year, using the formula given by Thomas (1981):

$$\Delta En = En(t + 1) - En(t) \tag{3}$$

Where, t and t + 1 respectively indicate the base year and the terminal year.

The values below one (1) indicates low magnitude, higher concentration and inward direction of sprawl, while values at one exactly is an indication that sprawl has remained constant from the previous year., and values above one is an indication of high magnitude, increased dispersion and outward direction of sprawl.

3 RESULT AND DISCUSSION

3.1 Analysis of Land use Land cover trend in Minna 1990- 2017

The changes in Land use Land cover in Minna from 1990 to 2017 appeared not to have maintained a consistent pattern, built up area in 1990 was 2.4% of the total land area and 3.8% in 2000, it then rapidly increased to 19.1% by the year 2010 and 48.2% in 2017, covering almost half of the total land area as depicted in figure 2, this is as a result of the rapid migration of people to Minna due to the better economic opportunities being a state capital and its proximity to the Federal Capital Territory Abuja.

Bare ground covered 4.2% of the total land area in 1990 and then decreased to 3.5% in the year 2000, which

may be due to reduced human activities in some areas where it existed and the ability of vegetation to regenerate, by 2010 it rapidly increased to 9.6% due to increased population and human activities, mostly illegal mining around Chanchaga area indicated in figure 2, dramatically it reduced to 1.8% of the total land area in 2017, largely due to reduced mining activities, the ability of the vegetation to regenerate and conversion into built up area.

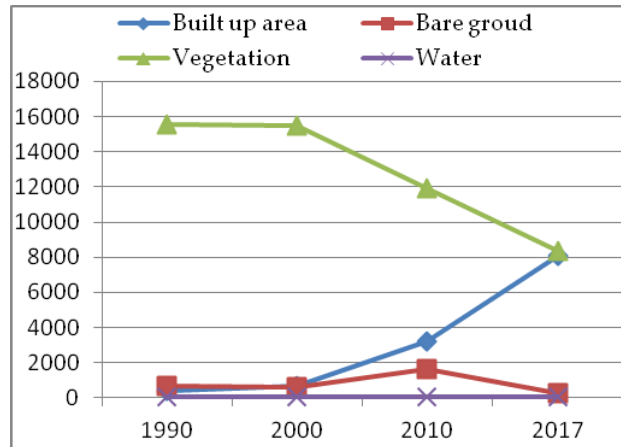

Figure 2: Land use Land cover trend in Minna 1990-2017.

Water in Minna was covering 0.5% of the total land area in 1990 and decreased to 0.3% in 2000, this is mainly due to drying up of most surface water in Minna as a result of building constructions and dumping of refuse in stream channels. It have remained constant through 2010 to 2017 at 0.3% of the total land area as indicated in figure 2, surface water left are concentrated to particular locations which have witnessed very little human activities.

The vegetation of Minna from 1990 to 2017 have been decreasing, it is inversely proportional to built up area as indicated in figure 2, it covered 92.9% of the total land area in 1990 by 2000 it reduced to 92.3, it rapidly decreased to 71% in 2010 and by 2017 it is covering 49.7% of the total land area, due to its conversion into built up area as can be seen in figure 3 and figure 4.

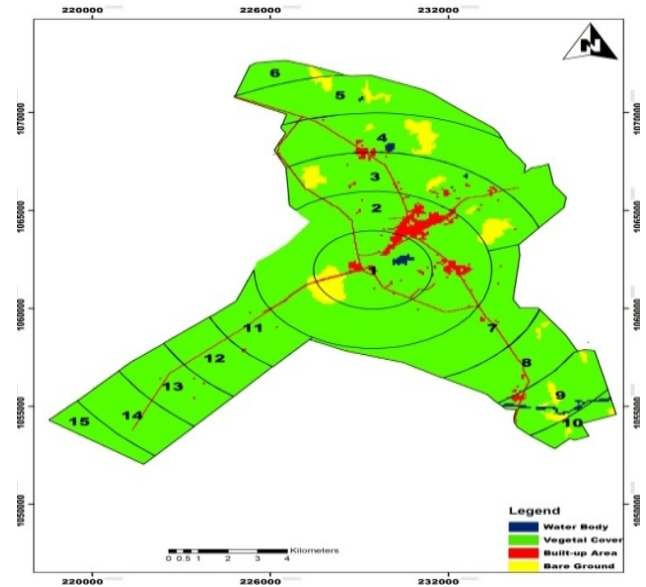

Figure 3: The classified image of 1990 and buffer zones

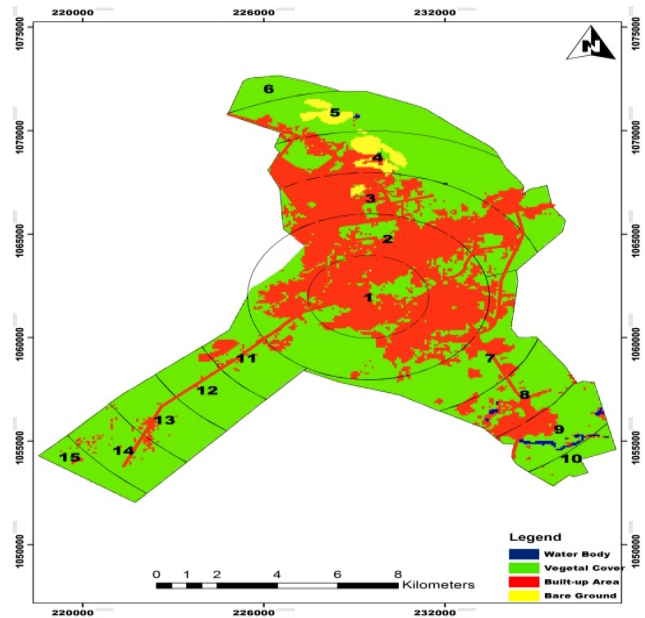

Figure 4: The classified image of 2017 and buffer zones

3.2 Urban Sprawl dynamics in Minna 1990-2017

The figure 5 depicts variations in urban sprawl and changes in its occurrence from 1990 to 2017, it is indicating that in 1990 and 2000 the rate of urban sprawl occurrence is low and is concentrated to some parts of Minna town, which indicates a compact form of settlement as displayed in figure 3, while in the year 2010 and 2017 the rate of urban sprawl occurrence became very high and evenly dispersed as can be viewed from figure 4, an indication that the town is approaching high rates of dispersal from where it will gradually become compact, generally urban sprawl have been increasing in its rates of dispersal throughout the period of study.

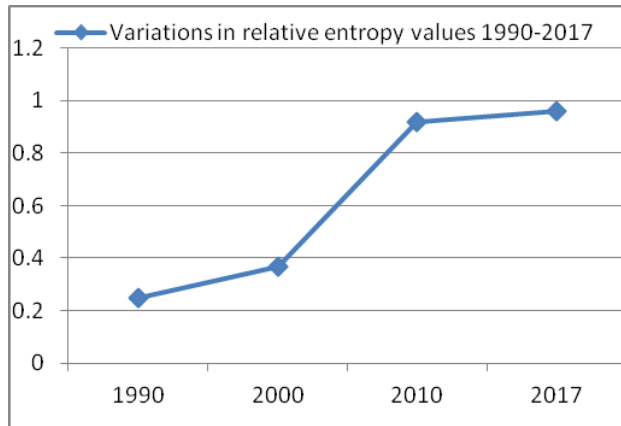

Figure 5: Variations in relative entropy values 1990-2017

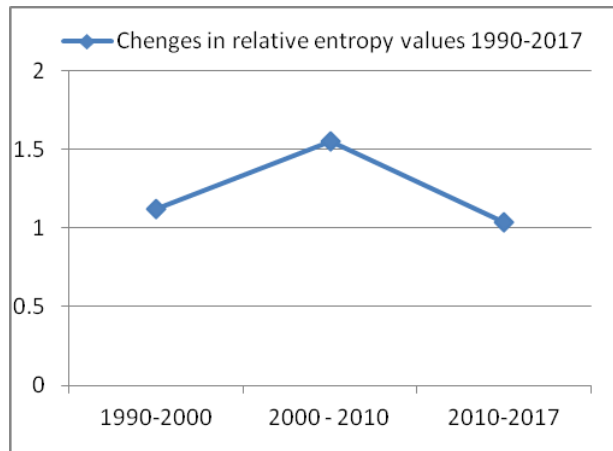

Figure 6: Changes in relative entropy values 1990-2017

Figure 6 shows changes in relative entropy values between the time periods under study which is indicating changes in urban sprawl behaviour; implying low magnitudes from 1990 to 2000 and from 2010 to 2017, while it has a high magnitude from 2000 to 2010 signifying the highest urban sprawl occurrence rate of the period under study. It can also be observed, that the variation indicates changes in urban sprawl behaviour from 1990 to 2000 and its behaviour from 2000 to 2010 which shows rapid rates of dispersal, high magnitude and an outward direction of sprawl occurrence, while its behaviour from 2010 to 2017 indicates compactness, lower magnitude and an inward direction of sprawl occurrence, an indication that urban sprawl occurrence slowed down from 2010 and 2017.

4. CONCLUSION

From the findings Urban sprawl in the study area was earlier compact with low magnitude from 1990 to 2000, it gradually became dispersed with high magnitude from 2000 to 2010 and is becoming compact with low magnitude from 2010 to 2017, it is directed towards the south western part of the study area with emerging environmental issues and rapidly decaying urban infrastructure such as

roads/streets, housing, electricity, water supply and waste management system. It is quite important to note that this research is limited to the dynamics of urban sprawl; it is therefore recommended that the scope of subsequent researches should include the effects of urban sprawl on environmental sustainability.

Attainment of Environmental sustainability in Minna will remain a mirage, if the current rate of urban sprawl and increasing environmental deterioration are not proportionately matched with economic growth and environmentally friendly development practices. Therefore the need for Proper environmental management is paramount to the sustainability of the environment, as this research provides information about the dynamics of urban sprawl occurrence, which will help environmental managers in decision making.

REFERENCE

- [1] A.D. Jiboye, "Sustainable Urbanization: Issues and Challenges for Effective Urban Governance in Nigeria," *Journal of Sustainable Development*, Vol. 4, no. 6, 2011, pp. 211-224.
- [2] C. Pedro, A. Gabriela, T. Mussie and A. Yikalo, "Entropy in Urban Systems," *Entropy*, Vol. 15, ISSN. 1099-4300, 2013, pp. 5223-5236.
- [3] D. Adedeji and O.I Eziyi, "Urban Environmental Problems in Nigeria: Implications for Sustainable Development," *Journal of Sustainable Development in Africa*, Vol. 12, no. 1, 2010, pp. 1520-5509.
- [4] F. Ujoh, I.D. Kwabe and O.O. Ifatimehin, "Understanding urban sprawl in the Federal Capital City, Abuja: towards sustainable urbanization in Nigeria," *Journal of Geography and Regional Planning*, Vol. 3, no. 5, 2010 pp. 106-113.
- [5] G. Srimanta, R. Moupriya and S. Arpan, "Identification of urban sprawl dynamics in a rapid growing city using GIS," *International Journal of Geomatics and Geosciences*, Vol. 3, no. 3, ISSN. 0976-4380, 2013, pp. 486-499.
- [6] R.J. Dawson, A. Wyckmans, O. Heidrich, J. Köhler, S. Dobson and E. Feliu, *Understanding Cities: Advances in integrated assessment of urban sustainability*, Final Report of COST Action TU0902, Centre for Earth Systems Engineering Research (CESER), Newcastle, UK. 2014.
- [7] R.W. Thomas, *Information Statistics in Geography in Concepts and Techniques in Modern Geography*, Norwich, England: Geo Abstracts, 1981 p. 31.
- [8] UNDP/NISEPA, "Niger state framework for integrated sustainable waste management," Niger State Strategic Waste Management Framework, 2009.

The Emerging Role of Pleadings in Determining Arbitrators' Jurisdiction

Felix Uwadia^{*}, Olusola Bejide and Sylvanus Sumanu

Department of Quantity Surveying, Auchu Polytechnic, Auchu, Nigeria
[*felixuwadia@gmail.com](mailto:felixuwadia@gmail.com)

Abstract— Arbitration was borne out of desire of parties to settle their dispute expeditiously, privately and devoid of the adversarial publicity and delays inherent in litigation. The benefits of settling disputes by means of arbitration is being eroded in recent times due to protracted litigation by parties that had hitherto embraced arbitration as they often resort to litigation, having failed to resolve their dispute via arbitration. One of the issues that is often contended by the parties has been that arbitrator exceeded his jurisdiction because award dealt with pleadings (matters) not covered by the submission to arbitration. The objective of the research therefore, is to ascertain the extent that pleadings delineate jurisdiction of the arbitrator. Cases on attacks on the award of the arbitrator with respect to jurisdiction and pleadings formed the focus of the study. The research is legalistic and entails the adoption of case-law based approach of research methodology. Cases were prioritized in their analysis and preference given to international arbitration cases, particularly case laws reported in The United Nations Commission on International Trade Law on Arbitration (UNCITRAL) Digest of Cases Laws, and Lexis Malaysia law report. The study revealed that arbitrator's jurisdiction is not strictly within pleadings.

Keyword— Arbitration; Arbitration Agreement; Award; Jurisdiction; Pleadings; Setting-aside award

1 INTRODUCTION

Arbitration is a process whereby the parties to a dispute agree to settle the dispute by an independent third party and to be bound by the decision he makes known as award.

The award of the arbitrator is usually prepared based on the submissions of parties in a process known as pleadings. Pleadings refer to a statement of facts which sets the basis of the plaintiff's claim of his or her action against the defendant. It is also used to refer to the statement of fact setting out the defence against the claims and any reply thereafter.

Pleadings provide the arbitrator with the jurisdiction to arbitrate on disputes referred to him. It is the only source of the arbitrator's powers that usually provides specific guide and direction to the arbitrator in all arbitral proceedings. Pleadings are also the only source of the arbitrator's jurisdiction that enables him to correctly delineate issues in all arbitral proceedings, especially in complex and complicated disputes.

Consequently, pleadings have accounted for the numerous attacks by aggrieved parties who usually contend that the arbitrator was unfair or that they were denied equity and natural justice because the arbitrator either did not take into cognizance all the issues pleaded by them or that he deliberately decided his award on issues that were not pleaded.

The jurisdiction of the arbitrator refers to his authority, mandate or competence [1]. It means the power of the arbitrator to arbitrate on disputes referred to him by parties in a legally binding arbitration agreement.

Despite the plethora of case laws and courts decisions on controversies pertaining to the jurisdiction of the arbitrator with regard to pleadings, there appears to be no end

to disputes and controversial court decisions and pronouncements with regard to attacks on arbitration awards and jurisdictional powers of the arbitrator by parties to arbitration agreement.

Therefore, this study has set out to find the extent that pleadings define the jurisdiction of the arbitrator against the backdrop of other sources that confer jurisdictional powers on the arbitrator.

1.2 Objective of the Research

To ascertain the conditions precedent for a recourse to a court against an arbitral award because it dealt with a dispute not contemplated by or not falling within the terms of the submission to arbitration, or contains decisions on matters beyond the scope of the submission to arbitration can be upheld by Courts.

1.3 Research Questions

The question that this study seeks to proffer answer is; why are Courts reluctant to uphold an attack to set aside arbitral award on the grounds that the award dealt with a dispute not contemplated or not falling within the terms of the submission to arbitration, or contains decisions on matters beyond the scope of the submission to arbitration.

1.4 Scope and Limitation of the Study

The study is confined to the study of the practice of arbitration proceedings with particular reference to pleadings of parties in dispute and how their pleadings delineate and define the roles and functions of the arbitrator globally.

The research is legalistic and will entail the adoption of case-law based approach. Cases will be prioritized in their analysis and preference given to international arbitra-

tion cases, particularly case laws reported in UNCITRAL Digest of Case Law on the Model Law on International Commercial Arbitration. Other sources of case laws are law report from states, regional arbitration institutions and Lexis Nexis group.

1.5 Significance of Study

This study has become imperative in order to cut down on arbitration time, cost and strain on business relationships by contending parties who revert automatically to litigation because the award dealt with matters not contemplated by or not falling within the terms of the submission to arbitration,

2. RESEARCH DESIGN

Legal case laws emanating from Courts judgments on Article 34(2)(iii) of *UNCITRAL Model Law on International Commercial Arbitration* domiciled in states and international arbitration rules and judgements of courts globally will be selected and analyzed to ascertain the legal doctrines applied in the decisions of the Courts.

3. RESEARCH METHODOLOGY

The legal doctrinal research methodology include the following:

- A Literature Review
- Historical Analysis of court judgements
- Content Analysis: Reading judgments, legislation and policy documents

3.1. Literature review

The submissions of parties in dispute define the strict and exact application of the powers of the arbitrator in respect of the issues pleaded [1]. The arbitrator is generally required by the rules of evidence to adhere to the pleadings of parties in the preparation of his award. Jurisdiction is the lifeblood of all legal proceedings [2]. Where a court or tribunal lacks jurisdiction the entire proceedings would be a nullity no matter how well conducted. The legal principle

that “you cannot put something on nothing and expect it to stand” remains trite and applicable to arbitration proceedings.[3]

3.2 Data collection

In order to achieve the objective of the research, data was sourced from the Malaysia Law Journal (MLJ) via the Lexis Nexis website. Extensive reference to the UNCITRAL case report was also made to obtain judgments of decided cases on arbitrator’s jurisdiction and pleadings. Secondary sources of data such as articles, journals, textbooks and other sources and related internet platforms were consulted. The number of cases collected, year and sittings of the cases are shown in the table below:

Table 1: Number of cases collected and sittings of the cases

Sittings of cases	Number of cases	Year of cases
New Zealand	1	1999
Mexico	1	2001
Singapore	2	2012
Zimbabwe	1	2013
Malaysia	1	2013
Ireland	1	2015
South Wales	1	2015
United States of America	3	2012, 2015

3.3 Data analysis

Law reports on arbitration proceedings in High Courts and Appeal Courts were collected and thoroughly studied and filtered to ensure that the cases analyzed were relevant to the issues of delineations of the arbitrators’ jurisdiction. Particular attention was given to the analysis and understanding of the legal principles and rules underlying the arbitrator’s awards and courts’ decisions in instances where cognizance of submissions of parties were taken by arbitrators and courts in arriving at their awards and decisions respective

Table 2: Summary of analysis of Cases and Courts’ judgement on attack to set aside an arbitral award because it dealt with a dispute not contemplated or not falling within the terms of the submission to arbitration, or contains decisions on matters beyond the scope of the submission to arbitration

Country	Case	Year	Facts of case	Decision of Courts
New Zealand	<i>Trustees of Rotoarai Forest Trust v. Attorney-General</i> [1999] 2 NZLR 452	1999	The plaintiff sought to set aside the award for breach of natural justice, alleging lack of opportunity to be heard.	The court dismissed the application to set aside the award and held that the plaintiff had enough opportunities to submit additional evidence and allegation, but decided not to do so.

Mexico	<i>Grupo Carce, S.A. de C.V v Pipetroniz, S.A. de Mexico</i> . Seventh Civil Collegiate Court of the First Circuit, RC-1542/2001, 6 th December 2001, Original in Spanish (Unpublished)	2001	Appeal against a decision of a lower court that overturned the setting aside of an arbitral award on pleadings related issues.	Held: an action to set aside an arbitral award was to be considered as a procedure to ascertain the existence and validity of the arbitral award itself, and not as a recourse against the award.
Singapore	<i>CRW Joint Operation v PT Perusahaan Gas Negara</i> [2011] 4 SLR 305, 319	2011	The appellant approached the high court to overturn the decision of a high court which had validated an award of arbitration tribunal because it had dealt with a dispute not pleaded	Held: Court is not concerned with the situation where an arbitral tribunal did not have jurisdiction to deal with the dispute which it purported to determine. Rather, it applies where the arbitral tribunal improperly decided matters that had not been submitted to it or failed to decide matters that had been submitted to it.
Singapore	<i>PT Prima International Development v Kempinski Hotels SA</i> [2012] 4 SLR 98	2012	Appeal against the verdict of a high court which had set aside an arbitration award because arbitrator made reference to an unpleaded issue in the preparation of the award.	Held: High court judge interpreted Art 34(2)(a)(iii) of the UNCITRAL model law narrowly
Singapore	<i>Pacific China Holdings Ltd (In Liquidation) v Grand Pacific Holdings Ltd</i> [2012] 4 HKLRD 569	2012	An action for Appeal court to set aside arbitral award because the appellant was not given proper notice of the arbitral proceedings and was also unable to present his case and the arbitral proceedings were contrary to the arbitration agreement	The Court held that it may refuse to set aside an award if a violation of the Article 34 UNCITRAL Model Law had no effect on the outcome of the arbitration
Malaysia	<i>Perwira Bintang Holdings Sdn Bhd v Kerajaan Malaysia</i> [2013] MLJU 1458	2013	Arbitrator demanded to know the quantity of excavation in rock and contractor petitioned the court because the arbitrator had considered an unpleaded issue in preparing his award.	Held: Award set aside because it was manifestly unlawful and unconscionable to subsist and the conclusions reached by the Arbitrator are patently and obviously illogical and perverse.
Ireland	<i>Delargy v Hickey</i> [2015] IEHC 436	2015	An application to set aside an award because arbitrator dealt with issues not contemplated by or not falling within the terms of the submission to arbitration or contains decisions on matters beyond the scope of the submission to arbitration.	Held: The grounds to set aside and/or resist enforcement under Article 34 and 36 of the Model Law respectively are discretionary in nature.
New South Wales	<i>Colin Joss & Co Pty Ltd v Cube Furniture Pty Ltd</i> [2015] NSWSC 735	2015	Joss had petitioned the court that arbitrator exceeded his authority (jurisdiction) and had not expressed a discernible methodology of reasoning, and had given reasons which were illogical, incoherent, inadequate, inconsistent, and ambiguous and had	Held: The applicant must demonstrate real unfairness or real practical injustice on how the arbitration was conducted or resolved by reference to established principles of natural justice or procedural fairness.

			acted unreasonably and irrationally.	
United States of America	<i>Private Assured Inc v Accessdata Corporation Limited</i> [2015] US Dist. LEXIS 53994	2015	AccessData approached the court to vacate the Arbitrator's award because arbitrator made an award on a claim beyond his contractual authority as the issues were not pleaded.	The Court held that despite any deficiencies in the Arbitrator's opinion about whether the Agreement was unambiguous, the court must uphold the Award because the Arbitrator arguably "interpreted the parties' contract."
Zimbabwe	<i>Gold Driven Inv. (Pvt) Ltd v TelOne (Pvt) Ltd & Another</i> [2013] ZWSC 9	2013	It is an appeal against the judgment of the High Court dismissing an application for review of an arbitral award which the applicant argued that the award ended up dealing with a dispute not contemplated by or not falling within the terms of the submission to arbitration as envisaged among other issues.	Held: Award did not constitute a palpable inequity in the proportions envisaged and magnitude described by the applicant

4. FINDINGS

Findings from the research revealed that the jurisdiction of an arbitrator is determined by matrix of factors and peculiarity of the dispute. It is the resultant effect of the interplay of these matrix of factors that determine his jurisdiction and the extent that pleadings affect his jurisdiction as well.

1. The courts in recent times have adopted very strong pro-arbitration stance and principle of minimal court intervention in arbitration and can only intervene only in circumstances where award is manifestly unlawful, unconscionable and the conclusions reached by the Arbitrator are patently and obviously illogical and perverse.
2. An award must be serious, even egregious such that a party has been denied due process before a violation of Article 34(2) of the Model Law
3. The Court may refuse to set aside an award if a violation of the Article had no effect on the outcome of the arbitration.

5. CONCLUSION

The study revealed that a party that "attacks" arbitration award to set it aside solely because the award dealt with matters not covered by the submission to arbitration has an arduous task of convincing the Courts to uphold such attack.

The Courts have also held that the provisions in arbitration laws that conferred powers on the Courts to set aside arbitration awards must be treated with minimal interference and not construed narrowly.

6. RECOMMENDATION

The researcher recommends that parties to arbitral agreement should not have recourse to set aside an arbitrator's award solely predicated on jurisdiction of the arbitrator with regard to pleadings,

ACKNOWLEDGMENT

The inputs of academic staff saddled with responsibilities of anchoring the Construction Contract Management programme of Universiti Teknologi Malaysia (UTM) are appreciated.

REFERENCES

- [1] Chow Kok Fong, "An outline of the law and practice of the construction contract claims". 1st Edition (Longman Singapore publishers, 1988), pp 422
- [2] Sundra Rajoo, "Law, Practice and Procedure for Arbitration". 1st Edition. (LexisNexis, 2003), pp 391
- [6] Sundra Rajoo, Dato' WSW Davidson and Ir. Harbans Singh KS. "The PAM 2006 Standard Form of Building Contract". 1st Edition (LexisNexis Malaysia Sdn Bhd), pp 837
- [3] B. Osadare, "Jurisdiction and Powers of Arbitral Who decides", March 21, 2016 [Online]. Available: <https://www.scribd.com/document/305482811/Jurisdiction-and-Powers-of-Arbitral-Award-Who-Decides>. [Accessed: July 15, 2015].
- [4] Lord Denning M.R. in *McFoy v. UAC LTD.* [1961] 3 WLR

Assessment of Financing Options for Housing Project Development in Lagos State, Nigeria

Sylvanus Sumanu, Felix Uwadia* and Olusola Bejide

Department of Quantity Surveying, Auchi Polytechnic, Auchi, Nigeria
[*felixuwadia@gmail.com](mailto:felixuwadia@gmail.com)

Abstract— Housing project financing in Nigeria is crucial, hence there is need to assess the various financing options for housing projects. The study examines the factors affecting the supply of finance on housing projects. The study also evaluates the factors affecting housing finance in a developing economy. The study reveals the impact of Nigeria financial system in lending out loans for housing projects in Nigeria. A total of 105 questionnaires were administered to various respondents in the construction sector and some financial institutions out of which sixty-six were retrieved and found suitable for analysis. Mean score ranking was used for data analysis. The study revealed that the major finance options for housing projects include consortium/syndicated loans, government grants, bank borrowing, personal savings, retained earnings, mortgage institutions, equity capital, debt factoring etc. The factors affecting the supply of finance on housing projects include regulation and monetary policies, inflationary expectations, efficiency of the financing system, level of economic activities, structure of the financial system and public-sector deficit. It is recommended that contractors, clients and property developers should know the various requirements and means to source for finance for housing development projects in Nigeria.

Keyword— Finance options; Housing development; Housing finance

1 INTRODUCTION

Construction is one of the most important activities in any economy. Large chunks of national resources are usually used in the provision of infrastructures, thus this sector plays an important role both in production and provision of services to the community. These infrastructures include buildings, bridges, dock, lands, airfield and host of other structure created to provide mankind with goods and services. Creedy [1] opined that the industry have common characteristic stemming mainly from physical nature of the construction product and its demands. Furthermore, finance may be described as the pivot around which other construction resources revolve. Since without it, it will be difficult to obtain other resources.

Hence, whenever housing projects are initiated by building contractors or clients, the problem of ensuring adequate financial requirement to complete the design, commence construction, and ensure smooth operation on site through to completion remain very glaring. Without adequate provisions for these financially, there will be budgetary difficulties, cash flow constraints that often lead to disputes and abandonment of projects [2]. In Nigeria, most housing projects require a commitment of huge amount of resources in form of money, materials, machine, and manpower. Of these four resources, money which may be described as the financial requirement play the pivotal role since other resources will hinge and revolve around it. From the conception of any housing project, arranging for financing is the first and paramount necessity of client and/or the contractor. In Keatsy & Waston's study (as cited [3]), have all identified the difficulties in obtaining the required finance as a major constraint in a developing country like Nigeria. Akintoye and Fitzgerald [4] carried their argument further by posing conceptual model for financ-

ing small contractors in developing countries.

1.1 The Needs of Financing Housing Projects

The need for project funding arises from the fact that the scope of most projects demands fairly large sums of money, which are usually beyond the means of the project sponsor. Thus, there is the need to develop financial packages that would assist the sponsor to realize the project objectives and plan [5]. In Nigeria as in most developing countries; project funding is necessitated as a result of inflation problems which give rise to fluctuations and cost overruns. Regulatory policies which arise from changes in government laws can sometimes pose problems of funding a project and includes such thrusts as import duty, excise duty and other forms of tariffs and interest rates.

1.2 Characteristics of Financing Housing Projects

Characteristically, no one party alone assumes the full responsibility of a project; rather project financing is made possible by combining undertakings and various kinds of guarantees by parties who are interested in a project. Pandey's study as cited in [6] articulated these attributes and posited that typical project financing package is noted for having a separate project entity created which receives loans from lenders and equity from sponsors. Debt services and repayments are entirely dependent on the projects' cash flows. Project financier's risks are entirely covered by the sponsor's guarantee. Third parties like suppliers, customers, government and sponsors commit themselves to share the risk of the project. The financing plan is therefore made sufficiently flexible to tap the most advantageous period in capital and financial market.

1.3 The Nigerian Financial System

The establishment of Central Bank of Nigeria (CBN) in 1959 effectively marks the beginning of formal and organized financial system in Nigeria. Before then, corpora-

tions operating in Nigeria could not raise capital for their operations while the surplus funds of financial intermediaries had to be invested in off-shore ventures. The CBN has since championed the process of the development of an efficient financial market through appropriate monetary policy instruments [7].

The Nigerian financial market can be broadly divided into two parts, the formal market system and the informal market. The formal system predates the colonial era and has refused to be totally eclipsed by the rather domineering informal market due to the inefficiencies in the formal system [8]. The formal system which understandably predominates the financial system comprises the money market and the capital markets. The money market deals with short term funds while the capital market takes care of long term finance.. The financial market can also be categorized into two segments which are the primary and the secondary segments. The primary segment of the market deals with fresh funds while the secondary segment provides liquidities to lender. It is important to note here that the formal system is highly regulated, supervised and controlled by several institutions including the Central Bank of Nigeria, the Securities and Exchange Commission (SEC), Nigerian Deposit Insurance Corporation (NDIC) and the Nigeria Stock Exchange (NSE). The major players in the money market are the Central bank, the Deposit money banks (DMBs) and discount houses. In the capital market, the major players are the private firms, development finance institutions (DFIs), and the Securities and Exchange Commission (SEC).

1.4 Factors Affecting the Supply of Finance on Housing Projects in Nigeria

Generally, the supply of loanable funds in Nigeria has been low as evidenced by the low level of aggregate saving to GDP. The supply of loanable funds have been constrained by low disposable income, low deposit rates, vis-a-vis the yield for alternative investment, a low level of banking habit and the existence of a large informal market. The demand for loanable funds in Nigeria has been significantly influenced by the fiscal operations of the government which have consistently relied on the banking system to finance their budgetary deficits leading to crowding out of developers of constructed facilities. Some of the factors that affect the supply of finance in housing projects in Nigeria are public-sector deficit, private savings, regulatory and monetary policies, level of economic activities, inflationary expectation, structure of the financial system and efficiency of the financial system.

1.5 Methodology

The methodology adopted for the study involved the use of a relevant research instrument which was administered to the various targeted respondents under the survey.

1.5.1 The Sampling Frame

The adequacy of a sample is known by how well it represents the whole population of participants from which the sample is intended to be drawn. The sampling frame is as shown in Table 1 below.

Table 1: **Sampling Frame of Respondents**

	Respondents	Number
1	Financial Institutions	49
2	Property Developers	25
3	Contractors	15
4	Sub-Contractors	25
	Total	105

1.5.2 Sample Size

There are several approaches to determining the sample size. These include using a census for population, imitating a sample size of similar study using published tables and applying formulae to calculate a sampling size. A census is attractive for small population e.g. 200 or less, although cost considerations make this impossible for large population. This research work adopted the formal method because of the large study population. The sample size in respect of the various categories of respondents was determined from the following formulae.

$$n = n^1 \frac{1 + n^1}{N}$$

Where n = sample size

N= Total population. The sample size for the study population is as shown in Table 2.

Table 2: **Sample size of Respondents**

	Respondents	Number
1	Financial Institutions	22
2	Property Developers	19
3	Contractors	12
4	Sub-Contractors	13
	Total	66

1.7 Method of Data Presentation and Analysis

Generally, the procedure and method employed in the analysis of data include a percentage representation of the opinion of the respondents collected through the instrument (questionnaire).

Mean score: This is the arithmetic average of the set of responses. It is calculated by summing all responses and dividing by the number of responses, possible score can range from 0 to 10.

$$\text{Mean score} = \frac{\sum Fx}{EF}$$

Where:

F= frequency

X=Ranking value

Where the likely score

5= Very important; 4=Important; 3=Neutral; 2= Fairly Important; 1=Not important

$$\text{Mean score} = \frac{(Fx5)+(Fx4)+(Fx3)+(Fx2)+(Fx1)}{FX}$$

The analysis of the responses under the survey is as indicated in the tables below

Table 3: Identified Sources of Financing Housing Projects in Nigeria

	Identified sources	5	4	3	2	1	Total	Mean Score	Rank
1	Loans/Syndicated/Consortium loan	25	20	16	3	2	66	3.95	1
2	Government Grants	23	18	19	4	2	66	3.85	2
3	Bank Borrowing	23	21	8	10	4	66	3.85	4
4	Personal Savings	20	19	18	5	4	66	3.7	4
5	Retainrd Earnings	18	19	21	6	2	66	3.68	5
©	Mortgage Institutions	25	10	18	7	6	66	3.62	6
7	Traditional Loan	14	19	5	20	8	66	3.47	7
8	Equity Capital	18	20	5	19	4	66	3.44	8
9	Debt Factoring	10	25	15	10	6	66	3.35	9

Table 3 reveals the major sources of financing housing projects in Nigeria. From the result, loan/syndicated/consortium loan was ranked first with a mean score of 3.95. This was one of the major sources of financing housing projects identified by respondents from the field. This is closely followed by government grants,

bank borrowing, personal savings and retained earnings with a mean score of 3.64. The least identified sources include mortgage institutions with a mean score of 3.62, traditional loan, equity capital and debt factoring with a mean score of 3.35.

Table 4 Identified Factors Affecting Housing Finance in Developed Economies

	Identified Factors	5	4	3	2	1	Total	Mean Score	Rank
1	Advancement in information Technology with financial Innovation	28	20	10	2	6	66	3.94	1
2	Broadened mortgage Contracts	27	24	4	5	6	66	3.92	2
3	Funding sources for lenders	19	15	17	11	4	66	3.52	3
4	Macroeconomic trend and Development	20	10	14	20	2	66	3.39	4
5	Deregulation and financial Liberalization	18	14	16	8	10	66	3.33	5

Table 4 shows the identified factors affecting housing finance in a developed economy with advancement in information technology with financial innovation ranked first with a mean score of 3.94. This is closely followed by broadened mortgage contracts, funding sources for lend-

ers, macroeconomic trend and development as well as deregulation and financial liberalization with a mean score of 3.33.

Table 5 Identified Factors Affecting Housing Finance in Developed Economies

	Identified Factors	5	4	3	2	1	Total	Mean Score	Rank
1	Regulation and Monetary policies	28	20	10	2	6	66	3.94	1
2	Inflationary expectation	27	24	4	5	6	66	3.92	2
3	Efficiency of the financial System	20	19	18	5	4	66	3.70	3
4	Level of economic Activities	18	19	21	6	2	66	3.68	4
5	Private savings	19	15	17	11	4	66	3.52	5
©	Structure of the Financial system	18	20	5	19	4	66	3.44	6
7	Public sector deficit	20	10	14	20	2	66	3.39	9

Table 5 shows the identified factors affecting the supply of finance on housing projects. Regulation and monetary pol-

icies is ranked first with a mean score of 3.94. This is closely followed by inflationary expectations and efficiency of

the financial system with a mean score of 3.70. Others are level of economic activities, private savings, structure of the financial system and public- sector deficit with a mean score of 3.39.

CONCLUSION

The study has been able to discover the various financing option for housing projects in developing economies like Nigeria. The study centers on various ways the government, private organizations as well as public and corporate clients could generate funds for housing development taking into cognizance the peculiarities of each of the financing options available for the purpose. It is envisaged that this will be for the overall enhancement of provision of relevant infrastructural facilities as well as the sustained growth of the construction industry.

1.9 Recommendation

Based on the summary of findings and conclusion, it is recommended that since the study have been able to identify major sources of financing housing projects, it is important therefore that contractors, sub-contractors, property developers etc should evaluate and subsequently harness the available finance options by satisfying the stipulated requirements for housing development in Nigeria.

REFERENCES

- [1] G. D. Creedy, "Risk factors leading to cost overruns in Highway Construction Projects", A Ph.D Thesis, University of Technology, Australia, 2006
- [2] C. A. Ajayi, "Analysis of default factors in residential mortgaging of the Federal Mortgage Bank of Nigeria and Oyo State Property Development Corporation. Ibadan, Oyo State, Nigeria", A Ph.D Thesis, Obafemi Awolowo University, Nigeria, 1990.
- [3] A. A. Kwake, *Construction project administration in practice*, Longman, London, UK: Spon Press. (1997).
- [4] A. Akintoye, and E. Fitzgerald, "A survey of current cost estimating practices in the UK". *Journal of Construction Management and Economics*, vol. 18, pp. 161-172. , January 2000.
- [5] G. J. Ritz, *Total construction project management* (International Edition). New York, USA: McGraw-Hill, 1994.
- [6] F. P. Eshofonie, "Factors affecting cost of Construction in Nigeria", MSc Thesis, Akoka, University of Lagos, 2008.
- [7] P.A. Bowen; E. N. Hall; J. Pearl and M, Cattel, *Building price modeling and price information management in South Africa*. Transactions of AACE International, 99, 48, 1999.
- [8] I. H. Seeley, *Building economics* (4th edition.). London, UK: Macmillian. (1997).

Embodied Energy and Carbon IV Oxide Emission Analyses of Sandcrete Blocks and Compressed Earth Bricks Houses

Aliyu Abubakar^{1*}, Abbagana Mohammed¹, Umar D. Abubakar.², Ibrahim A. Ikara¹

¹Department of Civil Engineering, Abubakar Tafawa Balewa University, Bauchi, Nigeria.

²Civil Engineering Department, Kaduna Polytechnic, Kaduna, Nigeria.

*aabubakar24@atbu.edu.ng

Abstract - This study analyzes the Embodied Energy (EE) and Carbon IV Oxide (CO₂) emission of Sandcrete Blocks (SCB) and Compressed Earth Bricks (CEB) houses. Energy and CO₂ are emitted in the process of manufacture, transportation and construction of buildings materials. These energies and carbon dioxide are embodied in the materials. Thus, an exploratory research method was used to assess the EE and CO₂ emission impacts of building materials for the two types of houses in Nigeria. A detailed inventory analysis approach was used with EE and CO₂ emission factors obtained from Inventory of Carbon and Energy (ICE) database. The findings revealed the EE and CO₂ emission for the CEB are 436,343.49MJ (2,288.59 MJ/m²) and 30,821.09 KgCO₂ (161.65 KgCO₂/m²) while for the SCB house are 632,298.58 MJ (3,316.37 MJ/m²) and 52,897.82 KgCO₂ (277.45 KgCO₂/m²) respectively. Thus, the SCB house expends 30.99% more EE and emits 41.73% more embodied CO₂ than CEB. The comparison revealed that the CEB house is more sustainable and environmentally friendly in terms of EE and CO₂ emission than the SCB house. Also these findings indicate the importance of considering EE and CO₂ emissions impacts of various materials before using them in constructions.

Keywords - Compressed earth brick; CO₂ emissions; Embodied energy; House; Sandcrete block.

1 INTRODUCTION

GLOBALLY buildings are responsible for a huge share of energy, water and materials consumption. In the construction industry, it has been established that 40% of CO₂ emission is from activities associated with buildings [1]. These activities include extraction of raw materials, processing the raw materials, manufacture of the building material, transportation to site and construction of the buildings. The EE and CO₂ emissions from the building materials make up an important share of the total life cycle energy and CO₂ emission of the building [2]. This is often ignored when only the energy efficiency of running the building (operational energy) is considered. Moreover, EE and CO₂ emissions are currently the two main parameters commonly used in assessing the importance of building materials [3]. The European Union (EU) Construction Products Directive recommended embodied energy as a key factor in the selection of building materials or construction products [4].

This paper analyzed the EE and CO₂ emission of SCB and CEB houses. The study used same building plan for the two different most common houses in Nigeria with equal area, features and fenestration in order to show the impact of material choice on the EE and CO₂ emission of the houses.

2 EMBODIED ENERGY AND CO₂ EMISSION

EMBODIED energy of a building is the energy consumed by all of the processes associated with the production of the building, from the mining and processing of natural resources to manufacturing, transport and product delivery. On the other hand manufacturing sector CO₂ emissions can be characterized as direct or indirect. The former are released as a result of activities directly related to manufacturing and construction processes on site. The latter are associated with the use of energy in construction-related activities [5]. Materials that have a lower embodied energy are more sustainable than those with a higher embodied energy.

Various approaches to measure EE and CO₂ emission employ different system boundaries and collect data from different sources, which could result in significantly different values of EE for the same product [6]. Basically there are four methods of measuring EE: process analysis, input-output analysis, hybrid analysis and inventory analysis. This study is based on inventory method of analysis.

Inventory analysis method involves the use of database containing EE and CO₂ values for common building materials. The data for the inventory were extracted from peer reviewed literatures on the basis of a defined methodology and criteria. It is considered that the strict criteria used in the selection of source material for the creation of

the database serve to significantly increase its accuracy and relevancy [7]. This method provides results with greater accuracy, and because of its flexibility, it is considered the most suitable method for analysis of heterogeneous materials such as building. The use of emission factors reduces the tedious tasks that would have involved chemical equations. This is because emission factors are expressed as quantity of embodied energy or CO₂ per functional unit. This is modelled mathematically as in equations (1) and (2).

$$EE_k = \sum_{k=1}^n (1 + \zeta_k) * Q_k * I_k \quad \dots (1)$$

$$EC_k = \sum_{k=1}^n (1 + \zeta_k) * Q_k * I_k \quad \dots (2)$$

Where: EE_k and EC_k are embodied energy and embodied CO₂ of material type *k* with units MJ and KgCO₂ respectively;

ζ_k is the waste factor (dimensionless) of material type *k*;

I_k is the embodied energy factor or embodied CO₂ factor with unit MJ/functional unit and KgCO₂/functional unit of material respectively.

METHODOLOGY

TO allow for clear comparison, same plan and specifications were used for both buildings. The plan size is 14775 x 12900 mm, which occupies 190.66 m² of land as shown in Figure 1. The plan containing 3 bedrooms, 1 living room, 1 kitchen, 1 dinning, 3 toilets, and a car porch. The materials used for the construction of the two houses are: aluminium, blocks, bricks, cement, glass, paint, laterite, plaster clay, steel, concrete, tiles and timber. The only variation in the two houses is the choice of block or brick materials. The 3-D views of the SCB and the CEB building were presented in Figures 2 and 3.

In general, the mass, Q, of any substance is related to the Volume V through the formula: Q = ρV, where ρ is the material density; Volume (V) = Length (L) × Width (W) × Thickness (T) of the material. The calculations of quantity of materials are shown in Table 1. Equations 1 & 2 were used to compute the EE and CO₂ emissions of the building materials. The results obtained are presented in Tables 2 for SCB and CEB houses respectively.

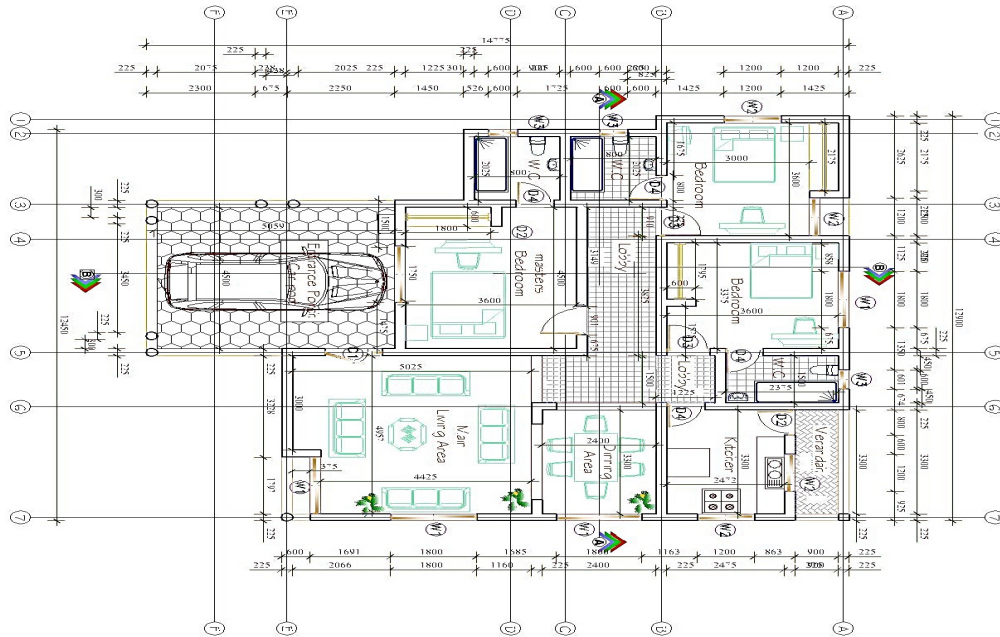

Figure 1: Plan for both the SCB and CEB houses



Figure 2: 3-D view of the SCB house

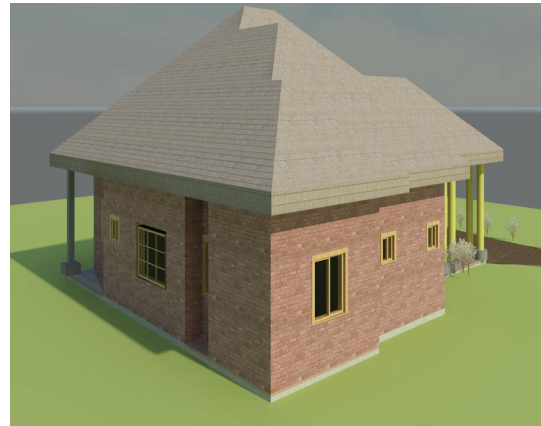

Figure 3: 3-D view of the CEB house

Table 1: Quantity of Materials for CEB and SCB houses

Member	Volume Calculations	CEB house	SCB house
Beam	Volume of concrete = (L x b x t) = 54.550m x 0.225m x 0.225m	2.762 m ³	2.762 m ³
Column	volume of concrete = Area of circular column x length of column + Area of rectangular column x length of column = 7(0.070695 m ² x 4.4m) + (0.225 m x 0.225 m x 4.4 m) = 2.177 m ³ + 0.22275	2.399 m ³	2.399 m ³
Floor	volume of concrete = Area of floor slab x thickness of floor slab = 155.05 m ² x 0.15 m	23.26 m ³	23.26 m ³
Brick wall	volume of brick wall = Area of brick wall x thickness of brick wall = 29.400 m ² x 0.225 m	6.615 m ³	-
Block wall	volume of block wall = Area of block wall x thickness of block wall = 337 m ² x 0.225 m	-	75.825 m ³
Tiles	volume of tiles = Area of tiles x thickness of tiles = 100 m ² x 0.008 m	0.8 m ³	0.8 m ³
Glass	volume of glass = Area of glass x thickness of glass = 22.66 m ² x 0.004 m	0.09064m ³	0.09064 m ³
Paint	volume of paint = Internal wall + External wall x 2 = 178.5 m ² + 158 m ² = 337 m ² x 1 m x 2	-	674 m ³
Plaster	volume of plaster = Area of plaster x thickness of plaster = 674 m ² x 0.025m	-	16.85 m ³
Laterite	volume of laterite = Total area of laterite filling x thickness of laterite = 102.01 m ² x 0.15 m	15.30 m ³	15.30 m ³
Steel	steel door = (L x b x t) = (2.1 m x 0.9 m x 0.003 m) x 2	0.01134m ³	0.01134 m ³
Hardcore	volume = Total area of hard core filling x thickness of hard core = 102.01 m ² x 0.15 m	15.30 m ³	15.30 m ³
Rafter	volume of rafter = volume of wall plates + tie beam + king post + struts + rafter + purlins + noggins = 4.28 + 8.06 + 4.54 + 13.22 + 7.21 + 4.86 + 5.74	47.91 m ³	47.91 m ³
Ceiling	volume of ceiling = Area x thickness = 100 m ² x 0.004 m	0.4 m ³	0.4 m ³
Aluminium window	volume of window = Area x thickness = 22.66 m ² x 0.00045 m = 0.010197 m ³	0.010197m ³	0.010197 m ³
Aluminium roofing sheet	volume of roofing sheet = Area of roofing x thickness of aluminium = 363.8 m ² x 0.00045 m = 0.1638 m ³ .	0.1638 m ³ .	0.1638 m ³ .

3 RESULTS AND DISCUSSION

TABLE 2 shows the results of EE and CO₂ emission of the two houses. The Embodied energy for the SCB and CEB houses are 632,298.58 MJ (3,316.37 MJ/m²) and 436,343.49 MJ (2,288.59 MJ/m²) respectively. Also, CO₂ emissions for SCB and CEB houses are 52897.82 KgCO₂ (277.45 KgCO₂/m²) and 30,821.09 KgCO₂ (161.65 KgCO₂/m²) respectively. The results for the two houses are presented on a bar graph shown in Figure 5. The results showed that the SCB house has higher EE and CO₂ emission than the CEB house.

Percentage Difference in EE of the two houses is:

$$\frac{EE_{SCB} - EE_{CEB}}{EE_{CEB}} \times 100 = \frac{632298.58 - 436343.49}{436343.49} \times 100 = 30.99\%$$

Percentage Difference in embodied CO₂ emission of the two houses is:

$$\frac{CO2_{SCB} - CO2_{CEB}}{CO2_{CEB}} \times 100 = \frac{52897.82 - 30821.09}{30821.09} \times 100 = 41.73\%$$

Hence, the SCB house expends at least 30.99% more embodied energy and emits at least 41.73% more embodied CO₂ than CEB house. This study agrees with the findings of Abanda *et al.* [8] who conducted similar research on EE and CO₂ analyses of mud-brick and cement-block houses in Cameroon, they reported that the cement- block house has more EE and CO₂ emission impact than the mud- brick house.

As described by Abanda *et al.* [8] embodied energy and CO₂ are important factors, but it is also important to consider the effects of material choice on the energy requirements for cooling and heating over the life time of the building. Some studies have revealed embodied energy to be equivalent to a few years of operating energy [9], although cases in which embodied energy can be much higher have also been reported [10]. In particular, in most developing countries, embodied energy of most traditional buildings can be largely compared to operating energy [9].

What these discrepancies suggest is that a holistic approach should be undertaken where embodied energy and operational energy should be considered in assessing the energy use and environmental impacts of a building.

4 CONCLUSION

THIS study analyzed the EE and CO₂ emission of SCB and CEB houses. The study used same building plan for the two different most common houses in Nigeria with equal area, features and fenestration in order to determine the

impact of material choice on the EE and CO₂ emission of the houses. The results revealed that the SCB house expends 30.99% more EE and emits 41.73% more embodied CO₂ than CEB. The comparison showed that SCB consumed more EE and emitted more CO₂ than CEB. Although these findings cannot be generalized, they nonetheless indicated the importance of considering embodied energy and CO₂ in making alternative choices for various building materials.

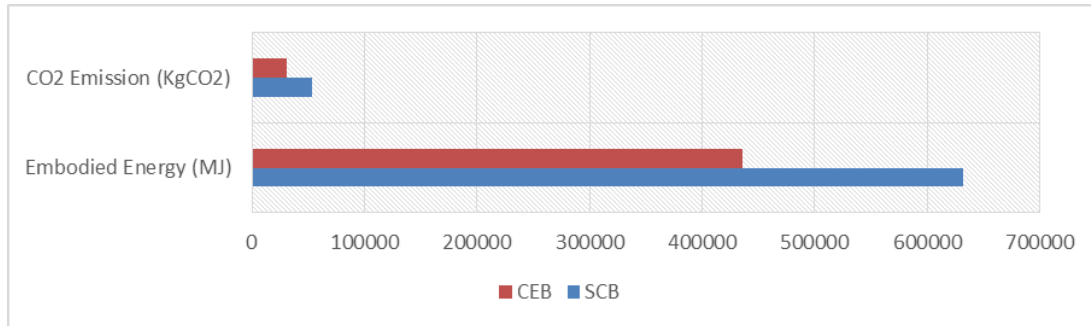

Figure 4: Comparison between the EE and CO₂ Emission of the SCB and CEB House

Table 2: Embodied energy and CO₂ Emission of SCB and CEB houses

Materials	Volume (m ³)	Density (kg/m ³)	Quantity (kg)	EE Intensity (MJ/Kg)	CO ₂ Emissions Intensity (KgCO ₂ /Kg)	Embodied Energy (MJ)		CO ₂ Emission (KgCO ₂)	
						SCB	CEB	SCB	CEB
Beam	2.76 2	2400	6628.8	0.95	0.130	6297.36	6297.36	861.744	861.744
Reinforcement	-	-	393.02	8.80	0.42	3458.576	3458.576	165.0684	165.0684
Column	2.399	2400	5757.6	0.95	0.130	5469.72	5469.72	748.488	748.488
Floor	23.26	2400	55824	0.95	0.130	53032.8	53032.8	7257.12	7257.12
Block wall	75.825	1800	136.485	0.99	0.136	135120.15	-	18561.96	-
CEB wall	6.615	1920	12700.8	0.83	0.082	-	10541.66	-	1041.47
Tiles	0.8	1700	1360	9.00	0.59	12240	12240	802.4	802.4
Glass	0.09064	2580	233.8512	15.00	0.85	3507.768	3507.768	198.7735	198.7735
Paint (Double Coat)	674	-	-	20.4	1.06	13749.6	-	714.44	-
Plaster	16.85	1900	32015	1.80	0.12	57627	-	3841.8	-
Laterite Soil	15.00	2500	37500	0.45	0.023	16875	16875	862.5	862.5
Door (Steel)	0.01134	7800	88.452	31.50	2.51	2786.24	2786.238	222.01	222.01452
Hard Core	15.00	2880	43200	1.00	0.056	43200	43200	2419.2	2419.2
Rafter	47.91	540	25871.4	7.80	0.47	201796.92	201796.92	12159.56	12159.558
Ceiling	0.4	540	216	20.00	0.98	4320	4320	211.68	211.68
Window (Aluminum)	0.010197	2700	27.53	155	8.24	4267.15	4267.15	226.85	226.85
Roofing Sheet	0.1638	2700	442.26	155	8.24	68550.3	68550.3	3644.2224	3644.2224
Grand-Total						632298.58	436343.49	52897.82	30821.09

REFERENCES

- [1] UNEP, "The Emissions Gap Report 2014.," United Nations Environment Programme (UNEP), Nairobi., 2014.
- [2] P. Matilainen and M. Airaksinen, "Reduction of energy use reduces both the primary energy use and CO₂ eq emissions. Energy efficient and low CO₂ office building.," *REHVA Journal*, 2012.
- [3] G. Hammond and C. Jones, "Embodied energy and carbon in construction materials," *Energy*, vol. 161, pp. 87-98, 2008.
- [4] B. Edwards, "Rough guide to sustainability: A design primer," RIBA Publishing, UK, 2010.
- [5] G. Milne and C. Reardon, "Materials: Embodied energy. Australia's Guide to environmentally sustainable homes," Australia, 2013.

- [6] L. Gustavsson and R. Sathre, "Embodied Energy and CO2 Emission of Wood and Concrete-framed Buildings in Sweden," in *2nd World Conference on Biomass for Energy, Industry and Climate Protection*, Rome, Italy, 2004.
- [7] G. P. Hammond and C. I. Jones, "Inventory of (embodied) Carbon & Energy Database (ICE), Version 2.0," University of Bath., UK, 2011.
- [8] F. H. Abanda, G. E. Nkeng, J. H. M. Tah and E. Ohandja, "Embodied Energy and CO2 Analyses of Mud-brick and Cement-block Houses," *AIMS's Energy*, vol. 2, no. 1, pp. 18-40, 2014.
- [9] M. Levine, M. Levine, D. Ürge-Vorsatz, K. Blok and et al, "Residential and commercial buildings. Climate Change 2007: Mitigation Contribution of Working Group III to the Fourth Assessment Report of the Intergovernmental Panel on Climate Change.," Cambridge University Press, Cambridge United Kingdom and New York, NY, USA, 2007.
- [10] G. Milne and C. Reardon, "Embodied energy Canberra: Your Home," Department of Industry, Australia, 2008.

Land Development and Planning Regulations in Lokoja, Nigeria.

Joy O. Obadoba^{1*} and Adams Ndalai Baba²

^{1,2}Department of Urban and Regional Planning, The Federal Polytechnic Idah Kogi state.

^{1,2}joycebenet@gmail.com; babaadams88@gmail.com

Abstract— *The system of planning regulations and standards in urban areas of many countries located in the Global South has been criticised due to its unrealistic ambitious standards and bureaucratic procedures. Access to formal land and shelter is put out of reach of low-income earners who have little or no choice but to end up living in unintended settlements, illegal, poorly, and haphazardly constructed structures, within the urban centres and sometimes at the urban fringes including poor access to basic infrastructure. This research carried out an assessment of land development and planning regulation in Lokoja, Nigeria by comparing formal and non-formal residential land developments. The study employed qualitative methods of data collection with information drawn from 15 respondents. Results from field measurement and interviews were analysed using ATLAS ti and presented using the descriptive method. Findings from the study revealed that residential land development is non-formal due to exclusion of low-income earners in accessing formal land. The officials involved in the land administration have weak institutional capacity to check and control land development effectively. Furthermore, lack of political will to develop a concise framework that is workable and inclusive limits the ability of major land developers to comply fully with the planning standards and regulations. The study recommends an inclusive land administration system that reflects the characteristics of citizens, especially the low-income earners.*

Keyword— Land Development; Planning Standards; Planning Regulations; Urbanisation.

1 INTRODUCTION

There are several studies on increasing urbanisation in the global south which is of growing concern for sustainable environment and development policies [1]. Nevertheless, despite the high rate of urbanisation, authorities involved have made little efforts to offer this increasing population the essential facilities and infrastructures not to talk of planned land for orderly development. Projections show that the current world population is now at 7.3 billion projected to reach 8.5 billion by 2030, 9.7 billion by 2050 and 11.2 billion by the year 2100 [2]. By 2050, Sub-Saharan Africa annual urbanisation growth rate is expected to be 0.9% with a population growth rate of 2.9% and an added 944 million urban dwellers bringing the total population to 2.4 billion [2]. Nigeria's population is on the increase with the current population put at over 182 million inhabitants.

Land was nationalised in Nigeria in 1978 through the Land Use Act which entrusted all land to governors of each state to be held in trust for the citizens [3]. The main reasons for nationalising land were to make land available to the government at the time and harmonise land ownership in the northern and southern part of the country. Prior to colonisation, the institution of land in Nigeria was simple approach administered through customary regimes. Statutory laws regulating land only became a necessary tool used by the colonial administration to gain access to land and to regulate planning and land use [4]. It did not fully capture the situation, culture, and ideologies of the Nigerian context.

Planning standards refers to the quality of level development should conform within a planning area in terms of building height, road width, building size, roof plans. While regulations described by Payne and Majale "as rule

or order of conduct prescribed by an authority by either requiring or prohibiting certain behaviour" [5]. Regulation is an essential instrument in urban development process and the housing market. Therefore, the regulatory frameworks are necessary to achieve land development in an orderly manner, ease efficient land management, enable the poor access improved housing and credit facility, attract and guide local investment [5]. Planned approaches are more beneficial in land development as evidence shows that non-flexible regulatory system without clear methods for alteration results in obsolete procedures. However, such approach may not be justifiably consistent with emerging opportunities [6]. The authors argued that land use regulations are a necessary tool used by the government when discussing inequalities. Nevertheless, the existing regulations on land use in the global south have not achieved much because of the method of applications and many of the theories on cities functionality stem from American and European context while growth is taking place in developing countries [7]. There is limited research carried out on non-formal land development in Lokoja especially on non-formal residential development. This gap in knowledge needs understanding in terms of compliance with planning standards and regulations by developers. Therefore, the study poses questions as to 'what constitute the administrative procedures for land development and in what ways is land development not conforming to planning regulation in Lokoja?

Urban development in Lokoja city has followed the same path driven by population growth like other emerging economies faced by urbanisation challenges. The total land area of Lokoja is 3,180 sq.km with about 10. 31sq.Km built-up areas as at 2005 [8]. The population of Lokoja as at 1991 was 77,519 and has increased to 196,643 in 2006 with a

growth rate of 3.03% [8]. The population was projected to have increased to 246,101 in 2014 by Census Bureau. Thus, urban development outruns planning, resulting in unorganised settlement patterns and land development in the state [9]. The urban area of Lokoja is located 200km south of the Federal Capital Territory (FCT) of Abuja in Nigeria. High demand outpaces land supply in Lokoja, and this may be ascribed to the increase in population, urbanisation, and the proximity to FCT in search of jobs and economic gains. These have put some strain on accommodation and shortage in housing. Demand for land by the residents has caused most landholders to illegally subdivide their plots without formal procedures being followed in line with the provision of the Land Use Act, or town planning regulations. Also, difficult access to formal land supply that matches with the demand.

2 METHODOLOGY

The study used qualitative method of data collection that relies on non-numerical data obtained from primary and secondary sources. It is the suitable method to measure process, perception on real-life situation [10]. Adopting the case study strategy, a non-probability sampling method was chosen and framed using purposive sampling, the respondents were selected based on their knowledge of the situation [11]. This is because the more information a sample holds relevant for the study, the lower number of participants needed [12]. The main source of data was through field measurements, semi-structured interviews with experts on informal sector activities by Skype, telephone conversation (e-interview). Four skilled research assistants were selected among co-workers and friends to aid in keeping appointment dates of scheduled interview with respondents. Pilot survey was carried out to ensure that questions are understood and not duplicated. The e-interview provided unprecedented opportunity with access to potential participants and information that would have been more expensive to reach the offices while going through the bureaucratic application procedures. In addition, State Town Planning Edicts of 1991 was used along with personal observation to keep the chain of evidence. The result was analysed using ATLAS ti with codes assigned and queried to reach the conclusion. The unit of analysis includes eleven land developers and homeowners drawn from Government Residential Area (GRA), which is formal and Adankolo and Lokongoma to represent the non-formal areas, three government officials and one informal sector expert. Thus, a total of 15 respondents was interviewed.

3 RESULTS AND DISCUSSIONS

3.1 The Administrative Procedures

The administrative procedures developers follow to be recognized as legal occupants and the process in Lokoja are constrained by long procedures as shown in Table 2. The interview with an official of the Ministry of Lands revealed that inefficiency arising from poor technical and human capacity contributes to poor administrative procedures for development.

The process begins with a Town Planning Scheme (TPS)

prepared by the Urban Planning Directorate in the Ministry of Lands before land allocation is issued to applicants. The TPS is a layout that defines the various uses within an area that the scheme covers. TPS is used due to the absence of detailed land use plans in Lokoja. The number of plots in a scheme depends on the size of the land that is available. Once the TPS has been prepared, it is then advertised via the media for 2 weeks. Interested applicants obtain a form known as "Land Form 1". The form gives the details of the applicant that is interested in that scheme. Although it is expected that the application will be on for 6 weeks, it may be extended. A meeting is held as stipulated by the Land Use Act (S.2.s. s2) which states that "There shall be established in each State a body to be known as "the Land Use and Allocation Committee (LUAC)" which shall have responsibility for advising the Governor on any matter connected with the management of land". Findings reveal that forms are put together in a box it is then mixed together and drawn randomly for allocation of vacant plots available. In addition, forms are also a revenue generation technique, thus, more forms are sold as against the number of plots available for allocation. Therefore, it is not a guarantee that an applicant will get an allocation. This is known by land developers and applicants. This is supported by one of the government official's respondent during the interview stating that "ordinarily it is supposed to take 3 months maximum but these days we have what we call the administrative bottleneck. The 3 months is already an administrative language. These days it ranges from 3 months to one year and it all depends on the government. However, there are 13 steps at different locations to be followed which further makes the processes cumbersome. Table 2 shows the steps that must be followed in land allocation process. This process as explained by some respondents is not a regular occurrence as it could take several years before a TPS is prepared. This is done at the whims of incumbent land and State Administrators in most cases for political advantage.

3.2: Development Compliance with Planning Regulations

The Kogi State Town Planning Board in combination with the Nigerian Institute of Town Planners Kogi State chapter reviewed the planning standards in 2017, yet, there are no major changes in the draft proposal, rather additional procedures with strict approaches to compliance and enforcement of the standards. The standards are to be enforced with strict measures put in place for violators. It further emphasises on developers to report to the office at each stage and level of development until the completion of development. It seeks a developer to provide site analysis reports, Environmental Impact Assessment Report, Survey plans, and application letter to the General Manager of the Board. Exclusion of the poor is still a major phenomenon that has not been addressed, there is no improvement on the existing standard in the state when compared with the Edict of 1991. However, the result shows that only the formal areas which accommodate the elites and politicians in GRA complied with the minimum regulations in terms of the setback of the buildings, building heights, floor area ratio. Adankolo and part of Lokongoma do not fully comply with the regulations. Al-

so, reports from Town Planning Board shows that Government Layout within Lokongoma has been grossly encroached upon by the community while individuals have further subdivided their properties for additional residential or commercial buildings.

Evidence from the field measurements shows variations in the level of compliance among the various land developers. From the eleven developers purposively selected, seven did not comply with planning regulations while only 4 followed the regulations in terms of the minimum setbacks to the road, the building height, floor area ratio and total land area coverage. A query from the codes assigned in ATLAS ti shows that the non-formal developers who did not comply with the required standard lowered the official standard in their development (see table 1). The three developers are within the formal area in the GRA while the others are in Lokongoma. From the interviews conducted, it was established by developers who reside in the GRA complied on the basis of avoiding embarrassment from the planning authority and for aesthetics. However, among developers in Lokongoma, there are varied measurements with none among the seven that conformed to the required standards. One of the respondents among the developers stated that "... there are a lot of bottlenecks that individual have to go through and therefore [I] ignore the procedures and do as [I] please..."

Table 1: Residential development regulations of respondents

	Planning Regulation	Official Sizes	Actual Measurement
1	Set back to the side, drive-in, rear, between buildings, between 2 storey buildings	1.8m ¹ / 3m / 3m / 3m / 4.5m.	1.0m / 2.0-2.5m / 1.5m / 1.5m / 2.0m.
2	Building height Storey building/	Lift must be included more than 4 floors.	There is no structure exceeding 4 storey in the study area.
3	Fence	2.4m high	vary between 2-6m high
4	Foundation	Not less than 2m below ground level.	Depending on the soil structure but less than 1.5m in the study area.

¹ m: Meters

The explanation for Table 1 shows the extent of non-compliance essentially in the non-formal areas. Report from ATLAS ti query tool shows that non-compliance according to the developers arose from informal acquisition of fragmented plots of land which hinders compliance to standards, this is as a result of hidden charges during land allocation by the government that limits access to formal land. In addition, the 2m foundation is seen as a waste of

resource by developers who engage in frugal construction design. Since the structures do not exceed 3-4 floors in the areas, hence there is no need to add lift in the development, loss of confidence on the government agencies due to poor monitoring system, land speculation further verified by the respondents from the Ministry of Lands and the Town Planning Development Board responsible for planning regulations and standards in the state. One of the respondents from the lands department stated that "the problem is that once government prepares a layout, the bulk of the land will be allocated among the government officials and their cronies therefore land becomes inaccessible to the ordinary person". The ordinary person will have to be forced to go to the community leaders where they have their money to pay directly and get the land".

Table 2: Basic steps for formal land allocation

Steps involved	Activities	Typical duration/Comment
1	Advertisement by the Ministry	2 weeks
2	Obtain and fill in application form with 4 passports	6 weeks to 1 year or more
3	Submit application form to the ministry of Lands	
4	LUAC ² meets to consider the applications	
5	Informed successful applicants	
6	An offer letter is issued	Within 2 years of the offer
7	Payment of premium upon acceptance	
8	Deeds plan and approval by the ministry	
9	Commissioner of land signs the draft certificates of occupancy	Officially 3 months to 3 years, however, there has been very few C of O allocated between 1996 till date.
10	Submission of draft C of O ³ to the governor for approval	
11	Governor returns the signed and approved C of O	
12	C of O is registered in the register	
13	Notify owners for the collection of approved C of O	

² Land Use Allocation Committee

³ Certificate of Occupancy.

Kogi State Ministry of Lands, 2017

CONCLUSION

Government efforts towards formal development in Lokoja city are largely compromised by the system of governance in place. Finding shows that there are inadequate access to formal land supply as land officials end up sharing plots to themselves when the layout is prepared, furthermore, weak political will and poor enforcement of planning regulations and standards are responsible for irregular and unorganised residential land development. There is exclusion of low-income earners in accessing formal land because of insensitive governance and poor land management procedures. Land supply not within the core urban area and not within the serviced land relegates the poor to seek alternative options.

The state lacks a visionary policy and design tool for a harmonised design pattern and structure. Lack of land use plan also hinders organized residential development. The bureaucratic administrative method of application of planning regulations and planned development has not been able to reduce irregularity and non-formal development in Lokoja. Hence, there is a need for government to respond to the massive failure of land development in the city in order to align with goal 11 of the Sustainable Development Goals which emphasises the need for inclusiveness in cities administration.

Further studies can examine new variables that can be introduced to investigate the political dimension and economic dynamism of unplanned land development which has not been captured in this study.

ACKNOWLEDGMENT

The author will like to acknowledge Baba, N. Adams (PhD) for his immense support towards this paper. Also Geoffrey Payne for his kind support.

REFERENCES

- [1] L. Kironde, "The Regulatory Framework, Unplanned Development and Urban Poverty: Findings from Dar es Salaam, Tanzania," *Land use Policy*, vol. 23, no. 4, pp. 460-472, 2006.
- [2] G. McGranahan and D. Satterthwaite, "Urbanisation Concepts and Trends," *International Institute for Environment and Development (IIED)*, vol. working paper, pp. 1-28, 2014.
- [3] A. L. Mabogunje, "Land Reform in Nigeria: Progress, Problems & Prospects," *WorldBank*, pp. 1-25, 2007.
- [4] F. Omole and O. B. Akinbamijo, "Land Development and Planning Laws in Nigeria: The historical Account.," *Journal of Law, Policy & Globalization*, vol. 8, pp. 25-31, 2012.
- [5] G. Payne and M. Majale, *The Urban Housing Manual: Making Regulatory Frameworks Work for the Poor*, UK and USA: Earthscan, 2004.
- [6] C. Whitehead et al, "Land Use Regulation: Transferring Lessons from Developed Economies," in *Urban Land Markets : Improving Land Management for Successful Urbanization*, Dordrecht, Springer, 2009, pp. 51-69.
- [7] A. Roy, "Urban Informality : Towards an Epistemology of Planning.," *Journal of the American Planning Association* , vol. 71, no. 2, pp. 147-158, 2005.
- [8] D. Alaci et al, "Spatial Growth Assessment with Remote Sensing Data for Central Nigeria," *Journal of Agriculture and Social Science*, vol. 7, no. 1, pp. 1-6, 2011.
- [9] J. E. Ukoje, "Impacts of Rapid Urbanisation in the Urban Fringe of Lokoja, Nigeria," *Journal of Geography and Regional Planning*, vol. 9, no. 10, pp. 185-194, 2016.
- [10] S. V. Thiel, *Research Methods in Public Administration and Public Management. An Introduction*, New York: Routledge/Taylor & Francis Group, 2014.
- [11] R. S. Barbour, *A Student's Guide to the Craft of Doing Qualitative Research.*, Los Angeles: SAGE, 2008.
- [12] K. Malterud, V. Siersma and A. Guassora, "Sample size in Qualitative interview studies," *SAGE*, vol. 26, no. 13, 2015.

The Roles of Town Planners in Disaster and Risk Management in Built Environment of Birnin Kebbi, Nigeria

Imole Oyelade ^{1*} and Elimisiemon Monday C. ^{2*}

¹Department of Urban and Regional planning, Waziri Umaru Federal Polytechnic, Birnin Kebbi, Nigeria

²Department of Architecture, Kaduna State University, Kafanchan Campus, Kaduna

* imole_oyelade@yahoo.com

Abstract - This paper examines the roles of Town planners in Disaster and risk management in built environment of Birnin Kebbi, Nigeria. The objectives are to: assess the roles of town planners in disaster and risk management and; identify factors undermining town planners in disaster and risk management within the study area. The primary and secondary data were used for the study. A total of 20 questionnaires were administered to the 20 registered members of the Nigerian Institute of Town Planning (NITP) and Town Planning Registration Council (TOPREC) named Kebbi study group in Birnin Kebbi. The study employed descriptive statistics base on the ranking of the mean score. The study identified three most important roles of town planners in disaster and risk management and also three most important factors undermining town planning profession in the area. The study is recommended to help government and policy makers to identify useful roles and challenges of the Town planners in the built environment.

Key words: Disaster; Reduction; Risk; Management; Spatial; Vulnerability.

1.0 INTRODUCTION

Planning of towns and cities had been a continuous exercise especially as it relates to the increase in populations. Urbanization in the cities had further affected the accessibility to land. In fact, most buildings had been converted to storey buildings and at the same time, attachment of commercial shops form the basis of encroachment on the residential buildings. This growth in population further creates slum and squatters' settlements in our environment. These are characterized with unauthorized building development, lack of drainage, absence of refuse dump, dirty and unkempt surrounding etc. The UNDP (2010) described Cities as the economic drivers within their countries and the center of intellectual, political, business and financial activities. These functions create a huge potential for influencing improvements in risk management. UNDP (2004) defines disaster as a serious disruption of the functioning of a society with widespread human, material or environmental losses which exceed the ability of the affected society to cope using only its own resource.

According to Ammann (2012), cities face increasing risks of impacts from large scale disasters. Risk in urban areas is a combination of two factors: first, location and exposure to hazards; and second, increased vulnerability due to poor local governance, environmental degradation, and the overstretching of resources (UNDP, 2010). Risk is identified as a phenomenon which occurs and likely to make various damage and losses in human lives and which can be avoided or reduced if human activities like the arbitrary urbanization and environmental pollution are avoided (Zelloum, 2009). Disasters often occur because risk reduction measures have not been considered or undertaken, despite their previous knowledge of existing hazards and threats (Bosher, 2014). There is the continu-

ous expansion of cities to accommodate rapid population growth, combined with in appropriate land-use planning and failure of urban authorities to regulate building standards, contribute to the vulnerability of urban populations. The UNDP (2010) asserts that disasters induced by urbanization increases the exposure of people and economic assets to hazards and create new patterns of risk, coupled with extreme natural hazards, result in risk accumulation.

In the light of this, Patton and Reed (1988), described urban and regional planning as a discipline and profession "that is concerned with the forces that influence the quality of life from the neighbourhood to the region, state and nation using a systematic and creative approach to address and resolve social, physical, and economic problem of the neighbourhoods, cities, suburbs, metropolitan areas, and larger regions. Alan and Jorge (2013) observed that the Intergovernmental Panel on Climate Change (IPCC) 2012 report acknowledges the importance of urban planning being integrated with risk reduction practices, but actually developing ways of achieving this integration still remains challenging. This paper therefore considers the assessment of the roles and the factors that undermine town planners in disaster and risk management within the built environment in Birnin kebbi, Nigeria.

2.0 THE CONCEPT OF DISASTER AND RISK MANAGEMENT

UNISDR (2012) described disaster as a serious disruption to the functioning of a society with widespread human, materials, or environmental losses which exceed the ability of affected society to cope using only its own resources. Wahab, Atebije and Yunusa (2013) observed that

disaster occurs when natural events, situations and normal human activities are impacted by significant and sudden adverse events that cause damaging impacts on human lives, property and the environment. Disaster impacts may include loss of life, injury, disease and other effects on human, physical, mental and social well-being, together with damage to property, destruction of assets, loss of services, social and economic disruption and environmental degradation (UNISDR, 2007b).

Disasters often occur because risk reduction measures have not been considered or undertaken, despite their previous knowledge of existing hazards and threats (Bosher, 2014). Similarly, risk is described as the combination of the probability of an event and its negative consequences. Zelloum (2009) asserts "Risk is identified as a phenomenon which occurs and likely to make various damages and losses in human lives and which can be avoided or reduced if human activities like the arbitrary urbanization and environmental pollution are avoided.

Zelloum (2009) emphasize that risk is characterized by the magnitude, intensity, frequency and return period. The risk is a neutral and natural phenomenon, neither good. Disaster management is a process which involves the coordination and integration of all activities necessary to build, sustain and improve the capability (of people) for disaster prevention, mitigation, preparedness, response and recovery (Khan et al, 2008). Disaster risk management is therefore the systematic process of using administrative, organization and operational skills and capacities to implement strategies, policies and improved coping capacities in order to lessen the adverse impact of hazards and the possibilities of disasters (UNISDR, 2012). In general, risk is measured as a combination of the probability of an event and its consequences.

Wahab, Atebije and Yunusa (2013) identified few examples of Disaster are as follows: Oil spills in Niger Delta, pipeline vandalization in Nigerian western part of the country, building collapse in Lagos, desertification/Drought in the North, loss of community land due to erosion in the South East, windstorm in the North, floods in some part of the country, atmospheric pollution and water pollution in the urban and rural areas, power or telecommunication outage due to thunderstorms or tornadoes, road accidents due to impact of climate change on road design, epidemics and diseases, and fire outbreak especially due to the ignition and overheating of electrical.

2.1 Physical planning measures and Tools used in Disaster and Risk Management

Urban planning encompasses a range of action modes and the development of knowledge or intelligence sets, its underlying attention to *spatial* relationships, between physical, social, economic and ecological systems provides a potentially powerful base for disaster risk reduction (Alan and Jorge, 2013).

Burby and Beatley et al. (1999) pinpoint the power of land use planning to deal with disasters, particularly in terms of the ways that social and organization aspects are typically drawn into planning approaches. According to Alan and Jorge (2013), land use planning can reduce losses

by (1) "affecting both the location and the design of urban development" and by (2) "helping create a knowledgeable constituency of citizens who support hazard mitigation programs". A key element of both urban planning (Rydin, 2007) and of Disaster risk reduction, Smith (2013) sees it as the gathering, development and application of various types of data or intelligence and its analysis as a base for action (Alan and Jorge, 2013).

The activities of planning actions in "plans" is incorporated into many disaster risk reduction approaches. Plans and the processes for their achievement will have a range of instruments, such as: action agendas; policies (decision rules for repeated actions); visions (images of the desired future); designs or master plans; and, strategies or decision making systems processes to modify plans and overall directions over time (Hopkins, 2001; Alan and Jorge, 2013).

King et al (2013) observe that planners have three main areas through which they may reduce hazard risk or reduce vulnerability to risk. These are the zoning of the existing and future land uses whereby development controls and building codes are applied as appropriate to the type of land and its structures, urban infrastructure and settlement design, and information and mapping. These activities primarily take place within the jurisdiction of local governments which experience constraints of resources and capacity.

According to Kotter (2003), it is necessary to use the instruments of spatial planning in contributing to the prevention of the risks and mitigating the effects of natural and environmental disasters. In the context of environmental disasters, spatial planning and land management have to support the following essential functions as described by Kotter (2003):

-*Early warning system*: Spatial planning requires a comprehensive data base, to get sound information about the spatial development.

-*Risk assessment and mapping*: Prevention of disasters requires a detailed information and data about the reasons and effects of hazards. This calls for a systematic framework of the assessment and mapping of disasters.

-*Prevention and reduction*: Spatial planning needs to analyze the interrelations between the spatial influences and the environmental disasters. This requires the improvement and establishment of new models of spatial development.

-*Risk Management*: Environmental disasters requires a certain infrastructure needed to realise the emergency plan and risk management plan based on the data available.

-*Reconstruction*: Spatial planning has to be standardized through the provision of innovative models for regional development.

Oyesku identified the failure managing Nigerian Cities as the failures in the roles of Town planners and the challenges are related to mismanagement of funds, inadequate data base map, lack of political will, lack of public participation, absence of development control mechanism,

poor awareness, inconsistent policy, poor enforcement and implementation of plans.

3.0 METHODOLOGY

This study employed both primary and secondary data. The primary data made use of questionnaires within the study area. The secondary data used include online Journals and textbooks. The study was conducted using only the registered members of the Nigerian Institute of Town Planning (NITP) and Town Planning Registration Council (TOPREC) named the Kebbi state study group. Questionnaire administration was adopted for data collection using Likert scale of Very Good, Good, Average, Bad and Very Bad. The data was analyzed using the mean scores of the descriptive statistics and on that basis, a ranking was done on the identified roles and factors that undermine the town planners.

Oyesku (2014) highlighted Seventeen roles of Town planners in City management and eight challenges of managing Nigerian Cities. The Variables used in his work were modified and used for this study.

4.0 RESULTS AND DISCUSSION OF FINDING

TABLE 1: THE ROLES OF TOWN PLANNERS IN DISASTER AND RISK MANAGEMENT

	ROLES OF TOWN PLANNERS	Mean score	Rank
1	Town planners are directly responsible for planning resilient city	1.55	11th
2	Town planners are involved in disaster and risk management of climate change	2.10	1st
3	Town planner have regular programme of awareness that update their profession	1.75	4th
4	Town planners go for annual training and equipping to handle environmental issues	1.30	14th
5	Town planners provide researches and dissemination of information to handle climate change	1.50	12th
6	Town planners are recognized for infrastructural provisions in the city	1.70	7th
7	Illegal or unapproved plans are future disaster to the nation	1.75	4th
8	Town planners functions aid provision of a safer city	1.90	2nd
9	Building plans are useful instruments in disaster and risk management	1.75	4th
10	Layout plans are useful tools used in disaster and risk management	1.85	3rd
11	Master plans are useful tools used in disaster and risk man-	1.75	7th

	agement		
12	Town planning education will avert possible disaster occurrence in our environment	1.65	9th
13	Town planners promote community development that aids sustainable development	1.60	10th
14	Town planners employ Geographical Information system in disaster prone areas	1.30	14th
15	Town planners help in disaster and risk management through zoning	1.45	13th

Source: Source: Kebbi NITP/TOPREC Study Group, 2017 and Variables from Oyesku (2014).

Table 1 presents the roles of town planners in disaster and risk management. The mean scores from the members of the study group help to weight these roles in accordance of their importance and then ranking assessment carried out. Table 1 identified the first ranking to be Town planners are involved in disaster and risk management of climate change. The second ranking is to that town planners' functions aid provision of a safer city and the third ranking is that Layout plans are useful tools used in disaster and risk management. All other roles are well represented but these three are identified, take the leading roles from the table 1.

TABLE 2: FACTORS UNDERMINING TOWN PLANNING PROFESSION IN DISASTER AND RISK MANAGEMENT

	FACTORS UNDERMINING TOWN PLANNERS	Mean score	Rank
1	Inadequate funding	1.85	6th
2	Lack of base-map and location plans	1.75	10th
3	Political interference on planning matters	1.85	6th
4	Inadequate planning tools and convenient working environment	1.75	10th
5	Absence of adequate population data	1.85	6th
6	Poor plan implementation and enforcement	2.10	5th
7	Lack of functional infrastructure	1.80	9th
8	Government inconsistencies in policy formulation	2.30	1st
9	Change in regime/political party which thus result in project abandonment	2.15	4th
10	Town planners violation in the codes and conduct of their professional ethic	2.30	1st
11	Town planning profession lacks public involvement and participation of the people risk management	2.30	1st

Source: Kebbi NITP/TOPREC Study Group, 2017 and Vari-

ables from Oyesku (2014).

Table 2 reflects the factors undermining town planners in disaster and risk management. The presentation indicates that the Kebbi NITP/TOPREC study group identified factors of Town planners' violation in the codes and conduct of their professional ethic, Town planning profession lacks public involvement and participation of the people, and Government inconsistencies in policy formulation with a mean score of 2.30 as the first-three factor undermining town planning profession. Next to this score is Change in regime/political party which thus result in project abandonment accounting for a mean score of 2.15 followed by poor plan implementation and enforcement which account for 2.10.

5.0 CONCLUSION

The study revealed the three most important roles of town planners in disaster and risk management within Birnin Kebbi. These are town planners are involved in disaster and risk management of climate change, town planners' functions aid provision of a safer city and that layout plans are useful tools used in disaster and risk management. The study revealed that three most important factors undermining town planning profession as; town planners' violation in the codes and conduct of their professional ethic, town planning profession lacks public involvement and participation of the people, and Government inconsistencies in policy formulation.

REFERENCES

- [1] Alan, M. and Jorge, L. (2013). *Urban Planning for Disaster Risk Reduction: Establishing 2nd Wave Criteria*. SOAC 2013 Conference
- [2] Ammann, W. J. (2012). Official Opening Statement. In: AMMANN, W. J., ed. *International Disaster and Risk Conference, Integrative Risk Management in a Changing World - Pathways to a Resilient Society*, Davos, Switzerland. Global Risk Forum.
- [3] Boshier, L. (2014). Built-in resilience through disaster risk reduction: operational issues. *Building Research and Information* 42(2): 240–254.
- [4] Burby, R., Beatley, T., Berke, P., Deyle, R., French, S., Godschalk, D., Kaiser, E., Kartez, J. May, P., Ishansky, R., Paterson, R. & Platt, R. (1999). Unleashing the Power of Planning to Create Disaster-Resistant Communities. *Journal of the American Planning Association*, 4 (2), 247-258.
- [5] Hopkins, L. (2001). *Urban Development: The logic of making plans*, Washington, Island Press.
- [6] Intergovernmental Panel on Climate Change (ICPP), (2012). *Managing the Risks of Extreme Events and Disasters to Advance Climate Change Adaptation. Special Report of the Intergovernmental Panel on Climate Change*, New York, Cambridge University Press.
- [7] Khan, H., Vasilescu, L.G., and Khan, A. (2008). Disaster Management cycle- A Theoretical approach. In Wahab, B., Atebije N. and Yunusa, I (2013). *Disaster Risk Management in Nigerian Rural and urban Settlement*. NITP/TOPREC Mandatory Continuing Professional Development Programme (MCPDP), Edited 2013
- [8] King, D., Harwood, S., Cottrell A., Gurtner, Y. And Firdaus, A. (2013). *Land Use Planning for Disaster Risk Reduction and Climate Change Adaptation: Operationalizing Policy and Legislation At Local Levels*. Centre for Disaster Studies, James Cook University, Australia.
- [9] Kotter, T. (2003). *Prevention of Environmental Disasters by Spatial Planning and Land Management*. 2nd FIG Regional Conference Marrakech, Morocco, December 2-5, 2003.
- [10] Oyesku, K. (2014). *Managing Fast Growing Cities in Developing Countries: The Role of Urban and Regional Planners*. Paper Delivered at the 27th Town Planning Registration Induction Ceremony in Abuja.
- [11] Patton, C.V. and Reed, K.E. (1988). *Guide to Graduate Education in urban and Regional Planning*. Sixth Edition. Milwaukee: Association of Collegiate Schools of Planning, Department of Urban Planning, School of Architecture and urban Planning University of Wisconsin.
- [12] Rydin, Y. (2007). Re-examining the role of knowledge within planning theory. *Planning Theory*, 6, 52-68.
- [13] Smith, K. (2013). *Environmental hazards: assessing risk and reducing disaster*, New York, Routledge.
- [14] UNDP. (2004). *Reducing Disaster Risk. A Challenge for Development a Global Report*. New York, United Nations Development Programme Bureau for Crisis Prevention and Recovery.
- [15] UNDP. (2010). *Urban risk management*. A United Nations Development Project. New York, USA.
- [16] UNISDR (2007b). In CHMUTINA, K., GANOR, T. and BOSHER, L., (2014). Role of urban design and planning in disaster risk reduction. *Proceedings of the ICE - Urban Design and Planning*, 167(3), pp.125-135.
- [17] UNISDR (2012). *Global Assessment report on Disaster Risk Reduction-Revealing Risk, Redefining development*. Geneva: UNISDR.
- [18] Wahab, B., Atebije N. and Yunusa, I (2013). *Disaster Risk Management in Nigerian Rural and urban Settlement*. NITP/TOPREC Mandatory Continuing Professional Development Programme (MCPDP), Edited 2013.
- [19] Zelloum, H. (2009). Urban seismic risk management: A methodology. *Journal of Geology and Mining Research*, Vol. 1(9) pp. 195-207. Available on <http://www.academicjournals.org/jgmr>.

Factors Critical to Industrialised Building System Performance of Nigerian Mass Housing Projects

Edo O. Ojoko^{1,2}, Mohd H. Osman¹, Rahman A. B. Ahmad¹, and Nahisham Bakhary^{1*}

¹ Faculty of Civil Engineering, Universiti Teknologi Malaysia, 81310 Skudai, Johor, Malaysia

² School of Environmental Studies, Federal Polytechnic Nasarawa, PMB 001, Nasarawa State, Nigeria

*norhisham@utm.my

Abstract: Adopting Industrialised building system (IBS) for project delivery, World over, has been recognized as a remedy for poor project performance. However, in most developing nations, especially Nigeria, its adoption for mass housing delivery has been confronted with a myriad of factors culminating in poor performance and low uptake. Therefore, this study is focused on identifying and evaluating those factors inhibiting IBS performance. Of the 64 sixty-four (64) factors identified from the literature and structured interview, experts' opinion (Delphi method) considered forty-seven (47) as critical to IBS project performance. Applying purposive approach for this pilot exercise in Abuja, 300 questionnaires based on a Likert scale of 1-5, (1-least significant to 5-Most Significant) were administered to multidisciplinary construction stakeholders. 210 (70%) responded within four weeks and both the descriptive and inferential statistics were employed in the data analysis. Although, the stakeholders considered all the 47 factors to be critical, however, forty (40) factors were perceived to be of high influence, and seven (7) factors of moderate influence on IBS performance. The five (5) leading critical success factors (CSFs) are; Clear and precise goals, knowledge & skills, planning & control top management support, and transportation. Knowledge of CSFs will assist Stakeholders in effective decision-making.

Keyword— Industrialised Building System, Critical Success Factors, Project Performance, Mass Housing Projects, Nigerian Construction Industry

2 INTRODUCTION

The construction industry, through the provision of infrastructure and shelter, plays a pivotal role in the socio-economic development and employment generation goals of any nation (Oladinrin et al., 2012). Although, studies attest to the industry's successful performance in enhancing the GDP and employment status of various nations (Oluwakiyesi, 2011; Ekong & Onye, 2013), however these are largely in developed countries (DCs) while those in the less developed countries (LDCs) for decades have been besieged with poor performances manifesting in project delays, cost overruns, poor quality, unprecedented abandonment and incessant building collapse (UN-Habitat, 2006). For instance, in Nigeria in the last three decades, this myriad of failure, especially in the sector is reflected in its minuscule contribution to the nation's GDP and employment generation (Oluwakiyesi, 2011).

In the building sector, a subset of the construction industry, the failure attributes of the projects are mostly associated with the prevalent high cost and slow delivery rate of the conventional construction method which is predicated on massive on-site activities and unskilled labour (Aladeloba et al., 2015). Unfortunately, since independence in 1960, the conventional method accounts for over 90% of building projects in Nigeria (Jiboye, 2011), and by extension, largely responsible for the current 17million housing deficit (Federal Ministry Lands, Housing and Urban development, FMLHUD, 2013). To provide the requisite solution, as evidenced by various studies (Latham; 1994; Egan et al., 1998; Thanoon et al., 2003; Blissmass and Wakefield, 2009), the Nigerian Government in 2011 embraced a paradigm shift from the conventional method of construction to the Industrialized Building System (IBS)

(FMLHUD, 2013). The adopted four (4) IBS types are; i). America Light Gauge Steel ii). Plassmolite/Plasswall iii) Interlocking Masonry blocks, and iv). Burnt bricks for a Pilot Housing Project in Kuje, FCT, Abuja (FMLHUD, 2013). However, in spite of the recorded favourable performances in DCs and in even the pilot housing projects in FCT, Abuja that encouraged its embrace in other geopolitical zones (FMLHUD, 2013) empirical observation and recent studies revealed poor performance and a low IBS take up in the Nigerian building industry (Kolo et al., 2014; Pour Fahiniam et al, 2017).

So far, list of contextual factors responsible for the poor performance are limited. Most of the factors presented by the few pioneer studies on IBS performance in the Nigeria building industry, are based on general construction projects from anecdotal sources (Kolo et al., 2014; Aladeloba, 2015). While the studies of Kolo et al., (2014) and Aladeloba (2015) outlined the likely causative factors based on literature review, that of Pour-Fahimian et al., (2017) only suggested a broad framework on general construction projects. The absence of context-specific approach in the studies makes the recommendations unlikely appropriate to resolving the challenges of IBS adoption in Nigerian housing projects (MHPs). The aim of this study, therefore, is to bridge this research gap by identifying and evaluating the factors critical to IBS performance in the MHPs delivery as perceived by key stakeholders in the Nigerian building industry.

2. CRITICAL SUCCESS FACTORS (CSFS) AND IBS PERFORMANCE

IBS, a term adopted from the manufacturing industry, is variously defined by construction stakeholders. In

general, IBS designates a method of mass production of components/buildings. It is also variously perceived as either a system and/or a process. Junid, (1986) defines IBS as an industrialized process by which components of a building are conceived, planned, fabricated, transported and erected on site. To Trikha (1999), it is "a system in which concrete components prefabricated at sites of factories are assembled to form structures under strict quality control and minimum in situ construction activity. In this study, IBS represents a process utilized for mass housing project delivery. While mass housing is considered as residential buildings, proposed and developed in standard multiple units on a substantial scale entirely by a government or in synergy with private concerns.

In comparison to the conventional method, although, adopting IBS offer higher benefits, however, evidence of its low performance is on ascendance (Kolo et al., 2014). In the UK, among many causative factors, Pan et al. (2007) attributed the leading issues to high initial capital cost, complex interfacing of components and systems. Lack of manufacturing capacity, a risk-averse culture, the fragmented nature of the industry, and government planning system are also contending factors. A related study in Australia, adjusting to processing change, high capital outlay, supply chain restrictions, lack of skills and requisite knowledge are the leading constraints to IBS uptake (Blismas and Wakefield, 2009).

In Hong Kong, Jaillon and Poon (2008) agreed that conflict with the design and construction processes and practices, unskilled labour, lack of motivation, and lack of client support are the leading factors constraining IBS performance. In addition to the foregoing factors, Arif et al (2012) in the Indian construction industry, highlighted high initial capital cost, few codes/standard, lack of guidance and information, low access to finance, industry fragmented nature, manufacturing low capacity, inexperience, legal issues and restrictive regulations as prime constraints to IBS adoption. In addition to the aforementioned, issues of Information Technology and procurement variability are topical in IBS projects of Malaysia (Lou and Kamar, 2014).

Although IBS adoption in Nigeria is still in its embryonic stage, Kolo et al. (2014) through literature review and empirical observations disclose that reluctance to innovate, lack of codes and standards, lack of supply chain integration and requisite skill are the leading constraints. Aladeloba et al (2015) itemized issues of high costs, lack of requisite skill and knowledge, supply chain, perception, motivation, communication and integration as core constraints to overcoming the challenges of poor IBS uptake in the Nigerian construction industry. To this, Ojoko et al., (2016) identified resistance to cultural change as the foremost constraint. This view shares some bearing with the findings of Pour Fahimian et al., (2017) that identified negative perception as a leading factor of IBS poor uptake in Nigeria. Other factors emphasized are lack of supporting infrastructure, wild fluctuation in housing demand, and low manufacturing capacity.

The foregoing revealed that the causative factors to IBS poor performance are not only numerous and multifaceted, but differ between projects types and locations. Therefore, to arrive at a comprehensive list of factors, this study combines multiple approaches in CSFs identification and evaluation.

and evaluation.

3.0 RESEARCH METHOD

The study employed a deliberate and extensive approach of causative CSFs identification through literature review, discussions/structured interview before justification by experts' opinion. This ensures a comprehensive list of CSFs from a variety of perspectives (Blismas & Wakefield, 2009). First, from literature sources a list of factors was obtained. Then discussion/structured interview on IBS issues relative to; organization, experience, awareness, material type, equipment, ease of usage, region of application, benefits and barriers was held with 12 randomly chosen IBS stakeholders (Registered with FMLHUD, Abuja). The response obtained was evaluated using simple frequency, and the factors with values above 50% were accepted (Blismas and Wakefield, 2004). In all, a list of six-four (64) contextualised factors was obtained.

3.1 Delphi Method

The preliminary list of sixty-four (64) factors was presented to a panel of 30 experts, out of which 27 (90%) responded in a two-phase Delphi technique. The experts are of diverse disciplines, consisting of six (6) Academia, seven (7) Contracting, ten (10) Consulting, and four (4) from client organization, with all having an average of 17 years experience. The list of the experts was sourced from the supervisory ministry, FMLHUD, Abuja. The first phase, besides item name moderation, required the experts to rate the causative factors on a five-point Likert scale (1- highly insignificant, to 5-highly significant). A total of forty-seven (47) success variables were selected based on a mean score of three (3). For the second phase, based on the same scale, the average score of the first exercise was provided to the experts and asked to further rate the factors indicating agreement or otherwise. The reassessed scores were used to calculate a final average score for all the CSFs. Any factor with a mean score of three and above (≥ 3) is considered to have a reasonable influence on project performance and thus accepted, while those with values below 3 are rejected (Chan et al., 2004). Table 1 shows the 47 factors that ranked above the threshold of 3 and thus accepted.

3.2 Design and Administration of the Questionnaire

In construction management research, questionnaire provides less biased results (Enshassi et al., 2010). A two-section questionnaire was developed with the first segment elucidating information on the respondents' background, while the second part investigated the influence of each factor on IBS performance. This pilot exercise was conducted within the FCT, Abuja being the nation's capital, it has a high presence of ongoing IBS projects. To eliminate ambiguity and ensure easy interpretation of result, with appropriate measurement of data on the ordinal scale, the Likert five-point scale was employed, where 1-represents-least significant and 5-most significant (Yang et al., 2012).

Based on purposive technique, 300 questionnaires were administered on the stakeholders (Client, Consultant, and Contractors, Project manager, Manufac-

turers and Suppliers) being the main players involved in Nigerian mass housing project (MHP). 210 (70%) stakeholders made up of various professionals responded within the four weeks of October 2015. This response rate in construction management field meets the threshold of 20-30 % (Akintoye, 2000).

Table 1: List of Accepted Success Factors

No	Factor	No	Factor
1	Level of automation	25	Project size & Value
2	Team integration	26	Socio-Cultural
3	Training of Personnel	27	Weather/Act of God
4	Clear and Precise Goals	28	Economics
5	Supply chain collabotion	29	Waste Disposal
6	Monitoring & Feedback	30	Risk management
7	Knowledge & Skills	31	Power (electricity)
8	Component Reuse.	32	Motivation
9	Buildability/Constructability	33	Personnel Commitment
10	Planning & Control	34	Authority/Responsibility
11	Transportation	35	Permit/ Regulations
12	Top Management Support	36	Product & Service Cert.
13	Component repeatability	37	Locations
14	Components interfacing	38	Strategic Value Chain
15	Equipment	39	Conflict Resolution
16	Raw Material		Water
17	Technology Transfer	41	Budget date
18	Communication	42	Procurement mgt
19	Warrant /Insurance Coverage	43	Vested Interest
20	Innovation	44	Schedule Updates
21	Standardisation	45	Storage
22	Stakeholder Management	46	Manufacturing capability
23	Modularisation	47	Sewage
24	Code & Standard		

3.3 Data Analysis and Results

The Statistical Package for Social Sciences (SPSS Version 20) software aided the data analysis and the internal consistency test was determined using the Cronbach coefficient alpha (Zhai et al., 2014). The analysis of the 47 factors signposts an internal consistency with a Cronbach's alpha value of 0.843 which exceeds the minimum threshold of 0.7 (Pallant, 2007). Civil engineers constitute the highest (33.5%) professionals of all respondents and are present to varying degrees in all the firms. Almost 70% of the respondents are within the 31-50years age bracket; an active age range considered of optimum performance in the construction industry. More than 65% of the respondents have over 11years experience in the construction industry and not less than 5years in IBS. Over 50% of the respondents work in the consulting and project management firms. These further add validity to this study since the firms were the domain of experts in project performance evaluation and management.

In order to determine if the 47 CSFs (Table 1) were similarly perceived by the respondents, Kendall's concordance coefficient was employed. If Kendall's coefficient equals one (1), then CSFs were identically ranked, but otherwise, if Kendall's coefficient equals zero (0) (Yeung et al, 2007). The ranked 47CSFs have Kendall's coefficient value of 0.115 which is statistically significant at 1% level. This suggests a general consensus

among the 210 respondents. To establish the general similarity of the respondents' rankings between the respondents; Spearman's rank correlation test was employed. At 5% level, the least Spearman's rank correlation coefficient (r) for the different pairs is 0.621 (Client-Contractor). Therefore, statistically, there is a general consensus among the stakeholders.

To enhance decision making, it is recommended for the conversion of any ubiquitous scale (Likert scale to three scale point). This "levels of mean Value Distribution" for a Likert scale five -point has 1.0-2.33 as Low; 2.38-3.67 as moderate and 3.68-5 as high (Jacoby and Matell, 1971). The mean scores for the 47 CSFs range from 3.986 to 3.252. Hence, the influence of all the factors lie above the low mean value of 2.33. This implies that each of the 47 factors can noticeably influence IBS performance. However, while forty (40) factors have high influence (above 3.68) on project performance, seven (7) factors exercise moderate influence (between; 2.34-3.67) on IBS performance. Table 2 shows the five factors with the highest influence on IBS performance.

Table 2: Five Factors with High influence on Performance

No	FACTOR	MS	SD	RANK
4	Clear & Precise Goals	3.986	0.904	1
7	Knowledge & Skills	3.976	0.935	2
10	Planning & Control	3.948	0.919	3
12	Top Management Support	3.938	0.479	4
11	Transportation	3.924	0.909	5

4.0 FINDING AND DISCUSSION

The mean scores for the 47 CSFs range from 3.986 to 3.252, implying that all the factors are above the low mean value of 2.33 (Jacoby and Matell, 1971). Although, this implies that each of the 47 factors can noticeably influence IBS performance but while forty (40) factors generate high influence (above 3.68) on IBS project performance the remaining seven (7) exercise moderate influence (between; 2.34-3.67).

Based on Pareto rule, the highest factor ranked factor has the greatest influence (Ogwueleka, 2011). Thus, for this study, the lack of clear and precise goals (3.986) has the most impact on IBS project performance. Like in most other nations, the Nigerian government is the initiator and foremost consumer of construction products. Although the government embraced IBS since 2011, till date, there are no defined underpinning measures (policy statements or study) targeted at making IBS implementation a viable option. Also, this finding buttresses the claim of about 67% of the respondents in the discussion/structured interview that lack of clear and goals was a major barrier to IBS uptake in Nigeria. For IBS success, the vision of all stakeholders must be anchored on clear and precise goals. Countries, with a good measure of success in IBS implementation (Sweden; UK) have clear and precise goals with IBS policies incorporated into their construction development plans and backed with regulatory institutions (Steinhardt and Manley, 2016).

Lack of requisite knowledge and skills (3.976) was the second highest factor influencing IBS performance. This finding is in consonance with the studies of Amade et al., (2015) and Pour Rahimian et al., (2017). The

stakeholders' perception also agrees with the 63% rating accorded the same factor by the respondents interviewed. Aribigbola (2008), argued that to attain the goal of adequate housing for all, requisite knowledge and skills must be enhanced. Unfortunately with regards to innovative construction method, the curriculum of most Nigerian tertiary institutions are limited in depth. Lack of sufficient planning and control attracted a mean score value of (3.948) rated third. This factor is intrinsically tied to the two earlier factors. Without a requisite knowledge and skills, it is impossible to evolve a clear plan, and by extension attain set objectives.

5.0 CONCLUSION

It is evident from this preliminary study embracing the IBS to overcome the huge housing deficit in Nigerian building industry is a step in the right direction. The 47 CSFs considered contextual out of the initial 64 factors by stakeholders are sufficient in resolving issues of IBS poor performance and low uptake in Nigeria. However, to improve on IBS performance, the gap in between stakeholders' CSFs perception homogeneity need future clarification and management.

The CSFs observed in this study is limited to MHPs' micro viewpoint, and could significantly differ from those of the macro viewpoint in same locality. Also, the influence of the interrelationship of the factors on IBS performance is yet to be conducted. Since this study is ongoing, the author shall engage Factor Analysis to investigate the influence of these inter-relationships among the identified CSFs. It is envisaged that the findings of this study would assist the stakeholders in establishing a more reliable reference in the drive towards improving the performance of IBS projects in both the region and regions with similar constraints.

6.0 REFERENCES

- [1] Akintoye, A. (2000) Analysis of factors influencing project cost estimating practice. *Construction Management & Economics*, 18(1), 77–89.
- [2] Aladeloba, E. A., Okesoto, J. O. And Olawale, S. O. (2015) Prospects of Industrialized Materials in Building Production in Nigeria International Journal of Development Research, 5 (01), pp. 3143-3148
- [3] Blismas, N and Wakefield, R. (2009) "Drivers, constraints and the future of offsite manufacture in Australia," *Construction Innovation*, vol. 9, no. 1, pp. 72–83 Goodier, C and Gibb, A. (2007) "Future opportunities for offsite in the UK," *Construction Management and Economics*, vol. 25, no. 6, pp. 585–595
- [4] Chan, A. P. C. & Chan, D. W. M. (2004) Developing a benchmark model for project construction time performance in Hong Kong, *Building and Environment*, 39: pp.339–349.
- [5] Egan, J. (1998) "Rethinking construction, Construction Task Force report", Department of the Environment, Transport and the Regions HMSO, London.
- [6] Enshassi, A., Mohamed, S., & Abushaban, S. (2010) Factors affecting the performance of construction projects in the Gaza strip. *Journal of Civil Engineering and Management*, 15(3), 269–280
- [7] Goulding J S, Rahimian F P, Arif M, and Sharp M (2012) "Off-Site Construction: Strategic Priorities for Shaping the Future Research Agenda", *Architectoni.ca*, Canadian Centre of Academic Art and Science (CCAAS), 1(1), 62-73
- [8] Hamid, A. K. (2009) Barriers to Industrialized Building System (IBS): The Case of Malaysia; the Problem Statement Research Methodology. A preliminary PhD study on Industrialised Building System. Built and Human Environment 9th International Post-graduate Research Conference, pp.1–16.
- [9] Jacoby, J. and Matell, M. (1971) Three-Point Likert Scales Are Good Enough. *Journal of Marketing Research*. 8(4), 495-500
- [10] Jiboye, A. D. (2011) Urbanization challenges and housing delivery in Nigeria: The need for an effective Policy framework for Sustainable Development. *International Review of Social Sciences and Humanities*, 2(1), 176–185.
- [11] Jaillon, L. and Poon, C.S. (2008) Sustainable construction aspects of using prefabrication in dense urban environment: a Hong Kong case study. *Construction Management and Economics*, 26(9), 953–66.
- [12] Junid, S. M S. (1986) Industrialized Building System. In Proceedings of UNESCO/FEISEAP Regional workshop, UPM serdang.
- [13] Kolo, S. J, Rahimian, F. P., & Goulding, J. S. (2014) Offsite Manufacturing Construction: a big opportunity for housing delivery in Nigeria. *Procedia Engineering*, 85, 319–327.
- [14] Ojoko, E.O., Osman, M.H., Rahman, A.B.A., Omar, W.S.W and Ojoko, O. (2016). Critical Success Factors of Industrialised Building System Implementation in Nigerian Mass Housing Projects. Proceedings of the 2nd Int. Conf. on Sc., Engr. & Soc. Sci. (ICSESS 2016) 29th May- 1st June 254-255
- [15] Ogwueleka, A. (2011). The critical success factors influencing project performance in Nigeria. *International Journal of Management Science and Engineering Management*, 6(5), 343–349.
- [16] Pan, W., Gibb, A. and Dainty, A. (2007) Perspectives of UK housebuilders on the use of offsite modern methods of construction. *Construction Management and Economics*, 25(2), 183–94.
- [17] Pour Rahimian, F. and Goulding, J. and Akintoye, A. and Kolo, S. (2017). Review of motivations, success factors, and barriers to the adoption of offsite manufacturing in Nigeria. [Procedia Engineering](#), 196. pp. 512-519.
- [18] Trikha, D.N. (1999) Industrialised building systems: Prospects in Malaysia, Proceedings World Engineering Congress, Malaysia
- [19] UN-Habitat-Agenda (2006). Available at [The-Habitat-Agenda-Istanbul-Declaration-on-Human-Settlements-2006.pdf](#)
- [20] Yang, J., Zhu, X. F., & Zhang, H. (2012). Group model exploration of housing industrialization. *Construction Technology*, 364(41), 95e98. In Chinese.

Rental Housing Affordability: A Case Study of Millennium Estate, Ifako-Ijaiye, Lagos.

Babajide J. Osunwusi^{*}, Temitope O. Lamidi and Chukwuemeka O. Iroham

Department of Estate Management, Covenant University Ota, Ogun State, Nigeria

[*babajideosunwusi@yahoo.com](mailto:babajideosunwusi@yahoo.com)

Abstract— Housing forms one of the basic needs of human beings. Maslow's Theory on Hierarchy of Needs sees that housing forms the foremost important needs, in addition to security, food and others, at the lowest among the five levels. It has been observed that housing is one of the first priorities for most households and it represents the largest single investment for most people, taking up between 50% and 70% of household income. Housing affordability has been widely recognized by many authors to be influenced by the levels and distribution of home prices, household incomes and the structure of financing costs. Against this background, the aim of this study is to analyse the affordability of housing units in Millennium Estate, Ifako - Ijaiye, Lagos State. Questionnaires were administered to 150 households living in the study area. The questionnaires were analysed using the Statistical Package for Social Sciences (SPSS) and results presented in frequency tables. The findings of this study established that a majority of respondents pay less than the benchmark of 30% of their income as rent. The study concluded that the housing units in the estate are relatively affordable. The Government was encouraged to maintain affordability of housing units in the estate.

Keyword—, Affordability; Housing; Housing Affordability; Income; Rental Value

3 INTRODUCTION

Housing forms one of the basic needs of human beings. Maslow's Theory Hierarchy of Needs sees that housing forms the foremost important need. The housing condition of a country is a pointer to the health motivation, economic well-being and the social circumstances of her citizens. To most groups, housing means shelter but to others it means more as it serves as one of the best indicators of a person's standard of living and his or her place in the society. Rental housing on its part makes up a critical segment of a nation's housing stock, providing a home for families and individuals unable to afford the cost of ownership or whose life circumstances simply make renting a better option (Cohen et al, 2010).

A report released by EFInA (2010) noted that 85% of urban population lives in rented accommodation, spending more than 40% of their income on rent. Affordability has become the key term in housing policy in both developed and those in transition. According to Aziz et al, (2010) affordability is mainly defined by the relationship between household's housing expenditure and income. The affordability of housing has become a common problem of summarizing the nature of housing problem in many market-based housing systems. Affordability problems can be viewed as operating at different levels, ranging from the narrower direct experience of severe problems of poverty and homelessness, through an intermediate level of risk, to a broader problem of access to market. Many authors argued that housing affordability is influenced by the levels and distribution of home prices, household incomes and the structure of financing costs, (Aziz et al, 2010).

According to Daramola and Aina (2012) house rent in major cities in Nigeria is about 60% of an average worker's disposable income. This, when compared to the 30%

benchmark can be said to be too high. Such a worker is referred to as being cost burden. This dilemma is however more pronounce in Lagos. The rise in rent has worsened inaccessibility to affordable housing. Increasingly, concerns have been expressed about affordability outcomes for working households, especially for low and middle income households, who are finding it difficult to rent or purchase private sector housing that is accessible to their place of work and who, as a result, bear the burden either of significant housing costs or of significant transport costs (Aziz et al, 2010).

For the purpose this study, focus would be on household income. More than 80% of Nigeria's live in rented housing with the low and middle income families representing 65% of Nigeria population which in turn represents about 85% of housing demand for the nation. (Alitheia Capital, 2012). Hence the study aims at analyzing the rental affordability of various housing units in the study area by ascertaining the proportion of annual income that is paid as annual rent.

2 LITERATURE REVIEW

A survey of literature reveals a lack of consensus among academics and housing development experts on how housing affordability should be defined and measured. This may be attributed to the fact that housing affordability is a contested issue in which different groups struggle to impose their own definition and solution to the problem. Feldman (2002) looked at the affordable housing shortage: the problem, its cause and solution. The study which was conducted in the US, adopted the 30% benchmark, stating that a unit is unaffordable if a household has to spend more than 30% of its income on it. The author identified irregularity of income as largely being behind

the affordability problem. He however restricted this analysis to the rental housing market as he noted that housing crisis is heavily saturated among renters. Belsky et al (2005) in measuring the nation's rental housing affordability problems in America were also of the view that households spending more than 30% are cost burdened and those spending more than 50% are labeled severely cost burdened. The authors used the American Community Survey (ACS) and the American Household Survey (AHS) as sources of data. The 30% benchmark was also identified by Aribigbola (2011), who identified housing affordability has a major problem of urban housing. The paper generated its data through a systematic survey of 1,266 household in the 9 political wards in the city of Akure, Ondo Nigeria. Structured questionnaires were administered to the households selected. The author used systematic sampling technique to select buildings at intervals of every twentieth building in the 9 political wards. The Chi-square test of independence was used to ascertain the association between monthly income and rents paid on housing by respondents of the study area. The author is of the view that households who pay more than 30 percent of their income on housing are considered cost burdened and may have difficulty affording necessities such as food, clothing, transportation and medical care. Aribigbola (2011) however affirms that despite the problems associated with the 30 percent threshold, it is currently the most widely accepted indicator of housing affordability.

Similarly, Abimaje et al (2014) carried out a study to evaluate housing affordability in Idah, Kogi State. The authors administered questionnaires in eleven neighbourhoods of Idah town which were randomly selected. Findings of the study revealed that majority of respondents spend above 30% of their monthly income on housing. This, according to the authors, is inconsistent with the 30% affordability benchmark. The study therefore concluded that majority in the study area cannot afford adequate housing

According to Ndubueze (2009) in urban housing affordability and housing policy dilemmas in Nigeria, rent-to-income ratio measures rental-housing affordability. In his criticism of the ratio, Ndubueze (2009) observed that the ratio has a tendency to record as 'affordable' when a household consumes less than the minimal socially accepted standard of housing in favor of more non-housing consumption. On the other hand, the ratio tends to show as 'unaffordable' situations where a household chooses to consume a higher than expected standard of housing while still able to consume more than the minimum standards of non-housing consumption.

Mulliner and Maliene (2012) carried out a study in which they noted that basing housing affordability on financial attributes (housing expenditure and income) fails to tackle the wider issues involved such as housing quality, location and access to services and facilities. The study is based on a two stage approach, first stage involving the identification of the attributes while stage two determines the level of importance or significance of these attributes. Broader attributes that determine housing affordability as identified by the authors via extensive literature review and semi-structured interviews with local authorities are: house prices in relation to income, rent in relation to income, interest rates and mortgage availability, availability

of private and social rented accommodation, availability of low cost home ownership products, availability of market value home ownership properties, safety/crime, access to public transport facilities, access to shopping facilities, access to health care, access to child care, access to leisure facilities, access to open green public places, presence of environmental problems, quality of housing, energy efficiency of housing, availability of waste management facilities and deprivation in area.

Boamah (2010) explored the affordable housing situation in Ghana in a bid to determine whether rental and owner occupied units are affordable. The study randomly surveyed one-Twenty (120) housing units each from Kumasi and Tamale. Findings of the study revealed that rental and owner occupied housing are unaffordable by most households. The author noted that this is as a result of low income levels and high unemployment rates which disqualify most households from getting access to credit facilities. Torluccio and Dorakh (2011) asserted that any rent would be affordable if it leaves the consumer with socially acceptable standards for both the housing and non-housing consumption after rent is paid. The authors are of the opinion that rent and income should have a long-run equilibrium relationship. In spite of its obvious limitations, rent-to-income ratio has continued to enjoy popular usage largely due to a lack of comparable alternatives that can be calculated and interpreted and understood with as much ease. Thus, it is adopted in this study.

3 RESEARCH METHODOLOGY

In order to achieve the aim of this research, questionnaires were administered to occupiers of properties in the study area. In this study, the sample frame is six hundred and sixty four (664) flats which is the total number of flats in the estate, this also indicates that there are a total of 664 households in the estate, this information was derived from the researcher's field survey. Nwanna (1981) advised that if a population is in few hundreds, 40% of the population or more could serve as a good sample. But if the population is in many hundreds, a 20% sample is a good representative, if a population is in a few thousands, a 10% sample will be appropriate and if a population is in several thousands, a 5 % of the population will serve as a good sample. Since the number of flats in the estate is 664, the sample size is taken at 22.6% giving approximately 150 flats. One hundred and fifty (150) flats were then randomly selected and surveyed out of which one hundred and twenty three (123) questionnaires were retrieved. The surveyed flats include three bedroom, two bedroom and one bedroom flats.

Out of the one hundred and twenty three retrieved, twelve were filled by landlords hence they were disregarded. The one hundred and eleven questionnaires valid represent a total survey response rate of seventy-four percent (74%). The data and responses in the questionnaire were collected and entered on a coding sheet after which it was analysed and expressed in percentages. Statistical Package for Social Sciences (SPSS) and statistical tables were used to analyse the data. The presentation of the primary data was done with tables, frequencies and percentages to draw conclusions from the findings.

4. DATA PRESENTATION AND DISCUSSION OF FINDINGS

4.1 Overall Fitness Assessment of Housing Units/Occupants Perspective

From analysis it can be deduced that majority (52%) of the respondents are of the opinion that the overall fitness of the units is fair. This is followed by 25.4% who believed it was in good condition. This implies that the housing units in the estate can yield its full rental value in the open market.

4.2 Proportion of Income Paid as Rent

Tables were employed to show the prevailing rental values of 1, 2 and 3 bedroom flats as well as the income of respondents in the study area.

Table 1: Average Annual Rent Paid by Respondents

Property type	Average rent	Frequency	Percentage %
1 bedroom	150,000	22	19.8
2 bedroom	250,000	55	49.6
3 bedroom	350,000	34	30.6
Total		111	100

Source: Field Survey, 2018

The average annual rent paid by respondents occupying 1, 2 and 3 bedroom flats are shown in Table 1. The table shows that the average rent paid by respondents occupying 1 bedroom is N150, 000, respondents occupying 2 bedroom flats pay average rent of N250, 000 while occupiers of 3 bedroom flats pay average rent of N350, 000 per annum. Majority of respondents in the study area occupy 2-bedroom flats.

Table 2: Average Annual Income of Respondents

Property type	Average Income	Frequency	Percentage %
1 bedroom	800,000	22	19.8
2 bedroom	1,525,000	55	49.6
3 bedroom	2,550,000	34	30.6
Total		111	100

Source: Field Survey, 2018

From the table above it is revealed that there are three income levels in the estate. The average income shows a ratio of 2:5:3, which can be interpreted as low-income earners, higher middle-income earners and lower middle-income earners. The study area can then be said to be dominated by middle-income earners.

Property type	Average Income	Average Rent	% of Rent to Income
1 bedroom	800,000	150,000	18.75
2 bedroom	1,525,000	250,000	16.39
3 bedroom	2,550,000	350,000	13.72
Total		111	100

Table 3: Percentage of Rent to Income

Source: Field Survey, 2018

The rent of each housing type was compared with income levels of residents to come up with the affordability levels. For the 1 bedroom flat, respondents with average income of N800, 000 per annum paid 18.75% of their income as rent, while for occupants of 2-bedroom flats, 16.39% of their income was paid as rent. For 3-bedroom, respondents paid 13.72% of income as rent. The analysis shows that all surveyed respondents paid below the 30% benchmark for affordability identified in literature. It is also within range of the 20 percent benchmark set by the United Nations. This finding conforms to the Nigerian housing policy which does not want any Nigerian to spend more than 20 percent of his/ her income on housing expenditure.

Investigation shows that apart from paying for rents, householders also pay other ancillary charges like electricity bills, water, sanitation, security, refuse disposal bills etc. However these ancillary charges were not included in the comparison as it is not part of basic rent.

CONCLUSION

This research has taken a critical look at conditions of housing as well as the affordability of housing units in the study area. Affordability expresses the challenge faced by households in balancing the cost of its housing, on the one hand, and its non-housing expenditures, on the other, within the constrictions of its income. Since the Nigerian housing policy does not want any Nigerian to spend more than 20 percent of his/ her income on housing expenditure, it can be concluded that the housing units in the estate are relatively affordable for middle-income earners who dominate the study area.

It is however imperative to note that this study focused just on rent in relation to income, other housing expenditures such as, electricity bills, security, refuse disposal charges and water were not considered in the study. Hence further research to address this limitation is highly recommended.

Lagos State Development and Property Corporation (LSDPC), Federal Housing Authority (FHA) and all other major stakeholders in the housing sector are encouraged to emulate the affordability of the housing rents in the study area which is below the 20% standard set by the United Nations as well as the 30% benchmark identified in literature review. Rent of the housing units should be monitored to ensure that prices do not rise beyond the reach of the low and middle-income earners, who the estate is originally intended for.

REFERENCES

- [1] Abimaje, J., Akingbohunbe, D. O., Baba, A. N (2014). Housing Affordability in Nigerian Towns: A case of Idah, Nigeria. *International Journal of Civil Engineering, Construction and Estate Management*, 1(2), 31-38
- [2] Aribigbola, A. (2011). Housing Affordability as a Factor in the Creation of Sustainable Environment in Developing World: The Example of Akure, Nigeria. *J Hum Ecol*, 35(2), 122-131.
- [3] Aziz, W. A., Hanif, N. R., & Singaravello, K. (2010). A

- Study on Affordable Housing within the Middle Income Households in the Major Cities & Towns in Malaysia. Centre for Studies of Urban and Regional Real Estate, Faculty of Built Environment University of Malaya, 2-7.
- [4] Boamah, N. A (2010). Housing Affordability in Ghana: A focus on Kumasi and Tamale. *Ethiopian Journal of Environmental Studies and Management*, 3(3), 1-11
- [5] Cohen, R., Wardrip, K., & Williams, L. (2010). *Rental Housing Affordability - A Review of Current Research*. The Center for Housing Policy.
- [6] Daramola, S. A., & Aina, O. (2012). *Planning Policies and Affordable Housing in Nigeria - An Analysis of Abuja Master-Plan Scheme and the Re-validation of Certificate of Occupancy*.
- [7] *Enhancing Financial Innovation & Access (EFInA)*. (2010). *Overview of the Housing Finance Sector in Nigeria*.
- [8] Feldman, R. (2002). *The Affordable Housing Shortage: Considering the Problem, Causes and Solutions*. Federal Reserve Bank of Minneapolis Banking and Policy Working Paper 02-2.
- [9] Mulliner, E., & Maliene, V. (2012). *What Attributes Determine Housing Affordability?* *World Academy of Science, Engineering and Technology* Vol 67, 695-696.
- [10] JNdubueze, O. J. (2009). *Urban Housing Affordability and Housing Policy Dilemmas in Nigeria*. A thesis submitted to the University of Birmingham for the degree of Doctor of Philosophy.
- [11] Torluccio, G., & Dorakh, A. (2011). *Housing Affordability and Methodological Principles: An Application*. *International Research Journal of Finance and Economics*, 65-68.

The Level of Students' Awareness on Maintenance of Sewer Blockage in Male Student Hostel

Abubakar Tafawa Balewa University Bauchi, Nigeria

Aminu Umar* Bukar Wakawa Usman and Abdul Isa Anakobe

Department of Architecture, Faculty of Environmental Technology, Abubakar Tafawa Balewa University Bauchi

*arcaminu1@yahoo.com

Abstract— *The high rate of reoccurrence of Sewer blockage in Nigeria University hostels has become disquieting, despite the existence of maintenance unit in the university. However, proper sewage maintenance could not be achieved without the users' (student) input. This paper assesses the level of students' awareness in terms of maintenance of sewage blockage in Abubakar Tafawa Balewa University Bauchi, Nigeria. Interview was used as a means of data collection. Twenty eight (n=28) students were randomly interviewed to capture their perception, opinion and general knowledge about maintenance of sewer blockage. The data was transcribed verbatim and analysed manually. The result reveals that many of the students are not much aware of sewage blockage maintenance which contributes much to the persistence of the problem. It is therefore, recommended that awareness campaign should be carried out among the students living in hostel. This can be achieved through proper orientation of the students on sewer blockage and proper implementation of blockage clearance practice and maintenance. Finally it is further recommended that the university authority should include a session on sewer blockage practice during the welcoming orientation of students in to the university, to increase the level of students' awareness about the sewer blockage and maintenance. This will assist to a great extent on the minimization of sewer blockage and the proper use of sanitary appliance by the students.*

Keyword— *awareness; maintenance; sewer blockages; students' hostel*

1 INTRODUCTION

Sewer is a large pipe, usually underground, that is used for carrying waste water and human waste away from buildings to a place where they can be safely disposed. Sewer also refers to an underground conduit for carrying off drainage water and waste matter (Fenner, 2000). Sewer can either be public or private; public sewer is a sewer that is being taken on by a sewerage undertaker because it collects drains from different households, usually the local water authority therefore taking full responsibility for it. Private sewer deals with a drain within a single unit of complex, which makes the occupants fully responsible for it {2}. Sewer blockage has been one of the major challenges faced in hostel building. It causes great deterioration of the building elements in terms of aesthetics and durability and also poses great risk to the health of the occupants and the environment. According to recent analysis, sewer blockage and overflow is responsible for causing 26% of malaria disease which is also the most common and deadly disease in Africa {3}.

Sewer blockages pose several problems to the functionality of the drainage system. This can include the loss of water closet (WC) facilities which are unable to discharge into the Sewer. The prevention of waste water removal because of a blockage can result in the emission of foul odours from surcharged manholes and yard gullies {4}. The continues hydraulic loading of a blocked sewer can result in the escape of sewage from manholes, inspection chambers or yard gullies and cause external flooding. This may result in contamination of garden or road areas which

will require cleaning and disinfection following the event {5}. External flooding can also result in pollution of natural water courses if an adequate pathway for sewage ingress into a water course exists. In the more extreme cases, sewer blockages can cause internal flooding of property. Aside from the distress and inconvenience caused to the household, this can also pose significant health risks through contamination by disease spreading pathogens {3}.

The main challenges to sustainable sewer system in story buildings, is something has to do with inability of authority to provide appropriately serviced sites for the multitude steaming {7}. Therefore certain guides should be developed to the occupants, to assist in minimizing the occurrence of blockages in sewer pipe lines and ways to handle blocked sewers.

The purpose of sewer system includes; flooding control, waste transport, water collection and recycling, often evolved through trial and error modification after the systems were initially constructed {6}. The causes of sewer system blockage may include; buildup of grease, debris or foreign object in the sewer lateral, sewer line collapse caused by old and deteriorated sewer pipe {5}, presence of debris entering the sewer system due to illegal pipe connection, partial or complete blockage caused by root intrusion into sewer pipe { 8}.

Since the causes have been identified, the need for proper sewer disposal and safety orientation should emanate from the need to ensure that students occupying the hostel building can be able to identify a number of factors which are associated with the increased blockage likeli-

hood so as to prevent the sewer system from complete or partial blockage. However in the same manner, the management of Abubakar Tafawa Balewa University (ATBU) has set up mechanisms by which a number of precautions can be embarked on. This can only be achieved if the students are educated on that particular aspect. Therefore, this study would investigate on the students' level of awareness on the sewer blockage.

1.1 Management of Sewer blockage

Ideologically, a good management of sewer blockage is very essential so as to ensure that partial or complete blockage in the sewer system do not occur and in the case whereby any student in the hostel notice any sign of a partial blockage in the system, must quickly notify the management to take an immediate action so as to prevent the total collapse of the sewer system. Prevention of sewer system blockage saves cost at a long run and reduces the spread of pathogens [5].

According to [9] Students must have an understanding or knowledge of the severity of the sewer blockage observed or anticipated in their hostels. Unfortunately, however, lack of awareness among students remains a barrier to prompt notification of blockage as most students face difficulties in recognising the symptoms of even the most basic forms of sewer blockage [10]. The reporting delay time is the time which elapses between the detection/observance of a sewer blockage and report to the maintenance department by the students. This depends mainly on the inconvenience which the blockage causes the students and is not a measure of the seriousness of the sewer blockage [11]. Lack of maintenance of sewer blockage awareness precludes students from identifying in time the significance and urgency of a repair [12] and also manifests in the wrong notion that sewer blockage has no impact on students' level of performance. [7].

2 METHODOLOGY

Data and information was collected from interview conducted by the researchers. Respondents comprised of students living in Hall II hostel only, it also comprises of first year to final year students. 28 students were randomly interviewed to capture their perception, opinion and general knowledge. The occupants were approach with open-ended questions and in line with that, the respondents gave their in depth view about the subject matter. The Data was transcribed verbatim and later analysed manually.

In the course of the interview conducted, information on the profile of the respondents was asked. Some of the questions the students were asked include years of study in the university, period of stay in the hostels, and experiences with sewer blockage. Question was also asked on the level of sewer pipe maintenance by the school and Students' level of awareness on causes of sewer blockage and maintenance.

3 FINDINGS

3.1 Respondents Information

A total of 28 target respondents were interviewed, and all of them responded to the interview effectively, achieving a 99% response rate. The high response rate is

attributed to the manner of approach to respondents. The statistics of the respondents, with reference to their levels in the university, shows that 41% of the respondents were 1st year, 14% were 2nd year, 18% were 3rd year, 11% were 4th year while, 16 % were in their 5th years. Concerning how long the students stayed in the hostel, 12 of the respondent representing 38% had stayed in the hostel for 0-1 year, 10 of the respondents representing 31% had stayed for the period of 2-3 year, while 10 of the respondents representing 31% had stayed for 4-5 year. This result obtained was appropriate because about 66% of the respondents had stayed in the hostel for 2-5 years.

3.2 Causes of Sewer Blockage

About 80% of the students are not aware of some of these causes and therefore contributing to the problem of sewer blockage because of their ignorant towards the causes and maintenance of the sewer. This scenario is very dangerous, as lack of knowledge of these causes among some students in the hostel pose great risks in case of any sewer blockage and over flow

3.3 Dangers of Sewer Blockage

When asked about the danger of sewer blockage, the students affirmed their exposure to the danger. However, they did not attached much important to it as they always stay in the hostel while the sewer is overflow and continues for several week without repair. This shows that students are still exposing to all dangers due to their lack of knowledge of its causes and how to prevent it. It is obvious that the management of the hostel does not give much attention to issues regarding sewer blockage and as such the problem continue to persist and pose serious danger to the occupants of the hostel building.

3.4 Blockage clearance practice

The hostel management and the school management as a whole have the responsibility of clearing blocked sewers and also periodic inspection and clearance of various man hole chambers and sock away pits in the hostels and also maintain or change old and damaged sewer pipes. This maintenance schedule have been put in place by many organizations including some Tertiary institutions school but are not fully implemented due to lack of supervision. When the students were asked about the clearance of the sewer when it is blocked, 70% showed lack of concern and said that is not their responsibility as it is the management responsibility to attend to the problem. However, if the students were informed that this is everybody's responsibility, they may ensure that no solid waste is allowed into the sewer system through the sanitary appliance and if by any mistake falls, it should be removed immediately.

3.5 Sewer Blockage Awareness

Knowledge on possible ways to avoid the occurrence of sewer blockage: 13% of the respondents were aware and 29% are fairly aware of possible ways. The remaining 58% were not aware of such measures. The study indicates that awareness campaign i on the causes of blockage is necessity to all students living in the hostel building. Students' ignorance about the subject is very dangerous as it can

subject them to health hazard.

Periodic maintenance and clearance of sewer: 8% of the respondents were aware and 29% are fairly aware of maintenance and clearance of sewer. The remaining 63% were not aware. It is always important for the hostel management to do periodical maintenance and clearance of the sewer system to control or avoid possible blockage, some of this maintenance includes inspection and changing of old and damaged pipes. The views of the respondent were sought on the possible number of times maintenance was carried out and also their role in sanitation, 90% of the respondents were not aware of periodic maintenance by the management and also their role in proper sanitation.

CONCLUSION

This study was undertaken to assess the level of awareness of students on sewer blockage in Hall II hostel ATBU Bauchi. In view of the information analyzed from the interview made during the survey it was evident that sewer blockage awareness is low amongst the students. Sewer blockage is clearly high and posing extreme danger to health, safety, general welfare and strength of the structure. It is evident that school management who are responsible for blockage clearance management and students' orientation on the causes and measure to minimize its recurrence are not given much attention to the maintenance aspect of the sewer. Finally it is acclaimed that the university authority should include a session on sewer blockage practice during the welcoming orientation of students in to the university. This will assist to a great extent to minimized sewer blockage and inappropriate use of sanitary appliance by the students.

ACKNOWLEDGMENT

The authors wish to thank Abubakar Tafawa Balewa University for supporting this research work.

REFERENCES

- [1] Fenner, R. A. 2000. Approaches to sewer maintenance: a review. *Urban water*, 2(4), 343-356.
- [2] DeSilva, D., Marlow, D., Beale, D., & Marney, D. 2011. Sewer blockage management: Australian perspective. *Journal of Pipeline Systems Engineering and Practice*, 2(4), 139-145.
- [3] Mukhtar, M. D., Indabawa, I. I., & Imam, T. S. 2010. Public health implications of sewage ponds in Kano metropolis, Nigeria. *Journal of Food Agriculture & Environment*, 8(2), 25-31.
- [4] Hongrong, Q., Jianzhong, L., Guohui, Z., & Luexuan, L. 2011. Study of problems and corrective actions of urban drainage network. In *Electric Technology and Civil Engineering (ICETCE)*. In a proceeding International Conference (pp. 1561-1564). IEEE.
- [5] James, B., Emma, H., Edward, K., Slobodan, D., & Zoran, K. Developing Decision Tree Models to Create a Predictive Blockage Likelihood Model for Real-World Wastewater Networks. *12th International Conference on Hydroinformatics, HIC 2016. Procedia Engineering* 154 (2016) 1209 – 1216.
- [6] Muleta, M. K., McMillan, J., Amenu, G. G., & Burian, S. J. (2012). Bayesian approach for uncertainty analysis of an urban storm water model and its application to a heavily urbanized watershed. *Journal of Hydrologic Engineering*, 18(10), 1360-1371
- [7] Armitage, N. 2011. The challenges of sustainable urban drainage in developing countries. In *Proceeding SWITCH Paris Conference, Paris* (pp. 24-26).
- [8] Hongrong, Q., Jianzhong, L., Guohui, Z., & Luexuan, L. (2011, April). Study of problems and corrective actions of urban drainage network. In *Electric Technology and Civil Engineering (ICETCE), 2011 International Conference*, (pp. 1561-1564). IEEE.
- [9] Kangwa, J. and Olubodun, F. (2003a) An investigation into home owner maintenance awareness, management and skill-knowledge enhancing attributes. *Structural Survey*, 21(2), p. 70-78.
- [10] Arthur, S., Crow, H., & Pedezert, L. (2008). Understanding blockage formation in sewer systems a case-by-case approach. *Water Manage. Proc. Inst. Civil Eng*, 161(4), 215-221.
- [11] Kavvas, M. (2002). An appraisal of sewer system problems in developing countries. *Water policy*, 4(2), 119-135.
- [12] Oladapo, A. A. (2006). A study of tenants' maintenance awareness, responsibility and satisfaction in institutional housing in Nigeria. *International Journal of Strategic Property Management*, 10(4), 217-231.

COMPUTING AND COMPUTING ENGINEERING

Real Time Face Recognition System based on Pattern Matching

Temilola M. Adepoju¹, Adebajo Adekiigbe², Adedayo Sobowale¹ and Blessing S. Akinola¹

¹Department of Computer Engineering Technology, Federal Polytechnic Ede, Osun State Nigeria

² Department of Computer Science, Federal Polytechnic Ede, Osun State Nigeria

*atemilola@gmail.com

Abstract—Face recognition is an interesting area of research today for the fact that face plays an important role in security of life and properties. Research has been done in areas of security such as biometric using finger print, still manipulation or hacking of biometric information is possible. Face recognition system can be a profound solution to these problems (manipulation and hacking) at any sensitive point such as airport, and access control at corporate environment. Therefore, this study developed a face recognition system based on pattern matching for access control. The input images were enhanced using histogram equalization while Principal Component Analysis (PCA) algorithm was employed to extract face features. The extracted features of the registered image from the database were used to compare the real time image using minimum Euclidean Distance (ED). The developed system was implemented on white and black faces. The white faces were obtained from exiting database (OUR database for face detection) while the black faces were acquired locally with a digital camera, to populate a database which was later used to compare real time faces. The recognition accuracy of the developed system with the OUR database and locally populated database are 94% and 98% respectively. This show that for any real time scenario the system can recognize human faces correctly without mixed-up. Therefore security of any point where thhe system is being implemented is 98% guaranteed.

Keyword— Accuracy, Computational Time; Biometric; face pattern matching; Principal Component Analysis (PCA); Euclidean Distance (ED)

1 INTRODUCTION

Given the requirement for determining people's identity, the obvious question is what technology is best suited to supply this information? (Madalina and D'Amico, 2004). There are many ways that humans can identify each other, and so is for machines. There are many different identification technologies available, many of which have been in commercial use for years. The most common person verification and identification methods today are Password/PIN known as Personal Identification Number, systems (Madalina and D'Amico, 2004). The problem with this or other similar techniques is that they are not unique, and is possible for someone to forget, loose or even have it stolen to or by someone else.

In order to overcome these problems considerable interest was given to "biometrics" identification systems, which uses pattern recognition techniques to identify people based on their characteristics (Omidiora 2013). Although traditional biometric methods of identification such as fingerprints, Iris scans and voice recognition are viable, they are not always the best, depending on where they will be used (Vanaja, Waghmare, and Chirchi, 2011). In applications such as Surveillance and monitoring of public places for instance, such methods would end up failing because they are time consuming and inefficient especially in situations where there are many people involved. Also, the cost of implementation is also a hindrance as some components might have to be imported. Biometric authentication is a

profound way to deal with these difficulties rather than using the traditional password systems. Potentially, biometric systems can be employed in all applications that need authentication mechanism, and so in all applications that today use passwords, PINs, ID cards, or the like (Madalina and D'Amico, 2004).

Biometrics is the science of automated recognition of persons based on one or more physiological or behavioral characteristics possessed by such individuals (Vanaja, Waghmare, and Chirchi, 2011). These physiological characteristics include face, fingerprints, iris, retinal features, hand geometry, and ears. Behavioral characteristics include handwritten signature, voice, keystrokes (typing), and gait (how a person walks). The current state of technology presents several uses of the biometrics and each has its own advantages and disadvantages according to the requirements on biometric identifiers.

A practical biometric system should have an acceptable recognition accuracy, speed with reasonable resource requirements. It should be harmless to users, be accepted by the intended population, and be sufficiently robust to various fraudulent methods. Over the years, fingerprints have been one of the most widely used and accepted biometric (Vanaja, Waghmare, and Chirchi, 2011). This is evidenced with the Chinese who have used fingerprints to sign documents for over

1000 years (Max, 2002)

However, human face plays an important role in our social interaction. Using the human face as a key to security, biometric face recognition technology is of significant attention in this research, as it presents a wide range of applications in Airport Surveillance, Private Surveillance, Access Control for PCs in a Corporate Environment, Added Security for ATM Transactions and law enforcement. As compared with other biometrics systems such as fingerprint or palmprint and iris, face recognition has distinct advantages because of its non-contact requirement process (Max, 2002). Face images can be captured from a distance without physical contact the person being identified, and the identification does not require interacting with the person.

In addition, face recognition serves the crime deterrent purpose because face images that have been recorded and archived can later help identify a person. Consequent to the advent of various high-tech devices and ideas, hacking has become increasingly high and as a result several security devices can be hacked or guessed by others thereby making individuals private and personal information vulnerable.

Biometrics such as fingerprints provides an alternative method but can be forged (gummy fingers). Hand geometry is not distinctive enough to be used in large scale applications likewise hand-written signatures can be forged (Vanaja, Waghmare, and Chirchi, 2011). However, face is unique among all humans. Thus, there is a need for an affordable and mobile system similar to human eye to identify a person.

2 LITERATUR REVIEW

2.1 Principal Component Analysis (PCA)

PCA is a well - known technique in statistics. It picks out patterns in variables. As a result, patterns rather than all data are studied. It reduces the dimensionality of data without a significant loss of information. It can be used for prediction, redundancy removal, feature extraction, data compression, and so on. PCA is a suitable tool for feature extraction because it identifies the variation between human faces, which may not be immediately obvious (Omidiora, 2006). PCA does not attempt to classify faces using familiar geometrical differences, such as length of the nose or the width of eyebrow but a set of human faces is analysed using PCA to determine which variables account for the variation in the face images (Omidiora, 2013). In face feature, these variables are called eigenfaces because when plotted they display a ghostly resemblance to human faces. Eigenface deals with projecting an image space linearly to a low dimensional feature space such that recognition of the faces is done in this low dimensional feature space (Cendrillon and Lovell, 2000). Mathematically, eigenface adopts the PCA. The eigenface finds the prin-

cipal components of the distribution of faces or the eigenvectors of the covariance matrix of the set of face images. According to the significance of the eigenvalues, the eigenvectors are ordered and each one accounting for a different amount of the variations among the face images. These eigenvectors can be considered as a set of features that together characterise the variations between face images.

PCA Method Steps are as follows (Cendrillon and Lovell, 2000).

- Training set of total M images are used to compute the Average Mean as shown in the equation below:

$$average = \frac{1}{M} \sum_{n=1}^M Training\ Images \quad (1)$$

- Original image will be subtracted from the Average Mean as shown in the equation below:

$$Sub = TrainingImages - Average \quad (2)$$

- Calculate the Covariance Matrix as shown in the equation bellow:

$$Covariance = \sum_{n=1}^M Sub(n)Sub^T(n) \quad (3)$$

- Calculate the Eigenvalues and Eigenvectors of the Covariance Matrix.
- Sort and choose the best Eigenvalues. The highest Eigenvalues that belong to a group of Eigenvectors is chosen, these M Eigenvectors describe the Eigenfaces. Given that new faces are encountered, the Eigenfaces can be updated or recalculated accordingly.
- Project the training samples onto Eigenfaces.

2.2 Euclidean Distance

Euclidean distance or Euclidean metric is the "ordinary" straight-line distance between two points in Euclidean space. With this distance, Euclidean space becomes a metric space. The Euclidean distance between points p and

q is the length of the line segment connecting them (\overline{pq}).

In Cartesian coordinates, if $p = (p_1, p_2, \dots, p_n)$ and

$q = (q_1, q_2, \dots, q_n)$ are two points in Euclidean n-space,

then the distance (d) from p to q, or from q to p is given by the Pythagorean formula: The position of a point in a Euclidean n space is a Euclidean vector. So, p and q are Euclidean vectors, starting from the origin of the space, and their tips indicate two points. The Euclidean norm, or Euclidean length, or magnitude of a vector measures the length of the vector as seen in Equation 4

$$\|p\| = \sqrt{p_1^2 + p_2^2 + \dots + p_n^2} = \sqrt{p \cdot p} \quad (4)$$

The distance between any two points on the real line is the absolute value of the numerical difference of their coordinates. It is common to identify the name of a point with its Cartesian coordinate. In one dimension, there is a single

homogeneous, translation-invariant metric (in other words, a distance that is induced by a norm), up to a scale factor of length, which is the Euclidean distance.

2.3 Review of Related Work on Face Recognition

Cohen, Nicu, Larry, Ashutosh, and Thomas (2003) developed a facial expression recognition from video sequences in their work, used dynamic classifiers, such as Hidden Markov Models. This method is proposed for person-dependent systems, as it is more sensitive to temporal pattern changes, in the case of videos. Studies by the same authors also recommend using static classifiers, such as Tree Augmented Naive Bayes, for person-independent scenarios.

Shamla and Kalpana (2011) proposed a label Self-Organizing Map (SOM) to measure image similarity. To achieve their set goal, they fed Facial images associated to the regions of interest into the neural network. At the end of the learning step, each neural unit is turned to a particular Facial image prototype. Facial recognition is then performed by a probabilistic decision rule. This scheme offers them very promising results for face identification when dealing with illumination variation, facial poses and expressions. The paper presented a novel Self-Organizing Map (SOM) for face recognition. Eventually, they had good features extracted due to SOM's topological ordering. The Facial Analytics results for the 400 images of AT&T database used reflects that the face recognition rate using one of the neural network algorithms SOM is 92.40% for 40 persons.

Also, Deepesh Raj (2011), developed an effective and real time face recognition system based on OpenCV and C++. The system uses Principal Component analysis for feature extraction and various distance classifiers such as the Euclidean distance, the Manhattan distance and the Mahalanobis distance. The technique used here involves generating the 'eigen faces' then projecting training data into face-space to be used with a PCA classification method and evaluation of a projected test element by projecting it into face space and comparing to training data. The system was tested on YALE Face database B and ORL Face Database. The recognition produced using different matching techniques are compared and the results were been presented. The correct recognition rate achieved using the Mahalanobis distance is 92.3% and 73.1% for the normal PCA with Euclidean distance.

Ojo, J. A. and Adeniran, S. A. (2011) employed two dimensional discrete wavelet transform (2D DWT) to extract features from face images; and hidden Markov model (HMM) for training, recognition and classification. The algorithms were tested with a subset of the AT&T database. The recognized images were verified for correctness, 80% correct classification (Hit) occurred while 20% were misclassified. The rest of the images that were not in the training set were used to test the false acceptance rate

(FAR) i.e. the ratio of the numbers of images falsely accepted to the total number of images tested and 0.02 FAR occurred.

In this paper, PCA will be used to extract specific features from acquired images and Euclidean distance to classify and obtain similarity of the images.

3 METHODOLOGY

The complete framework for the face recognition which involves feature extraction and pattern matching is presented in Figure 1.

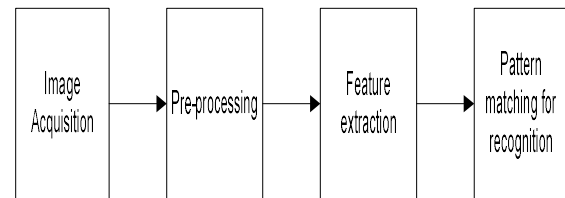

Figure 1: Framework of the developed system

The first step is the acquisition of black face images using conditions such as facial pose, angle and expression. The pre-processing stage was performed using histogram equalization while the extraction of specific features was carried out using PCA as stated in equations (1) to (3). Based on the extracted features, mean Euclidean distance was used for identification of few black faces in real time following equation (4). Figure 2 shows the step by step procedure to achieve the developed system.

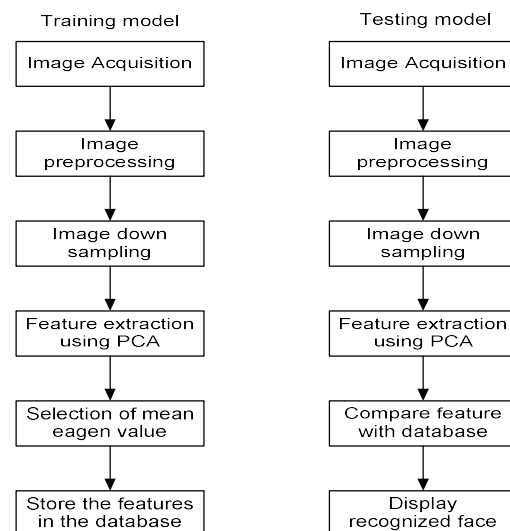

Figure 2: Developed face recognition model

Given a set of N face images (training images) to be tested or recognized, feature extraction is first performed. The eigenface from the training set is calculated and only the M images that correspond to the highest eigenvalues is kept. These M images define the "facespace". As new faces

are encountered, the “eigenfaces” can be updated or recalculated accordingly. The corresponding distribution in M dimensional weight space for each known individual is calculated by projecting their face images onto the “face space”. Determining whether the image corresponds with face in the database or not by checking the closeness of the image to the face space and the face with most likelihood is identified to be the one representing the face. Euclidean distance was used to test if the face is in the training set or database. If the likelihood is within the stated distance, the face is recognized to be in the training set or in the database. The testing of the system was carried out such that real time face images were used to evaluate the performance with respect to sensitivity and accuracy using, True Positive (TP), True Negative (TN), False Positive (FP) and False Negative (FN) as performance indices. The study was developed in a MATLAB 8.0.0 (R2013a) environment.

Sample of white and black faces for the training and testing of the system is presented in Figure 3(a) and Figure 3(b) respectively.

The following metrics are used for analyzing and evaluating the recognition accuracy of the system;

- i. True Positive (TP) when a trained face is correctly classified with the same face on database,
- ii. False positive (FP) when a trained face is wrongly matched with another in the database,
- iii. True Negative (TN) when a face that does not exist in the database is not recognized.
- iv. False Negative (FN) when an untrained face is not identified by the system as existing in the database
- v. The recognition accuracy is obtained by using the equation 5

$$Recognition\ accuracy = \frac{TP + TN}{Total\ Image}$$

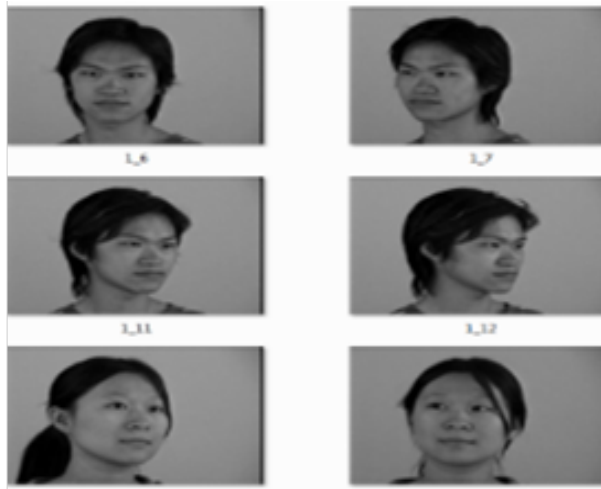

Figure 3(a): Sample of white faces from OUR database



Figure 3(b): Samples of locally acquired black face

4 RESULT DISCUSSION

The recognition system is used to detect or reject the identity that a user claims. Figure 4 depicts the interface of the MATLAB application and its response after an individual has been verified by the system. Several faces of different persons were trained by the system and subsequently real time faces of such persons were used to verify the system’s ability to recognize the face-image of the same person taken under various conditions. As seen in Figure 4, description of the system after the face image has been called in for the verification process was shown. The real-time face was used to verify the individual and as seen in the Figure 4.2 the person was granted access because a face whose Euclidean distance falls in range has been detected. However, Figure 5 depicts a face image that was wrongly classified by the system. It is worthy to be noted that the threshold value determines how strong the system is in rejecting false values.

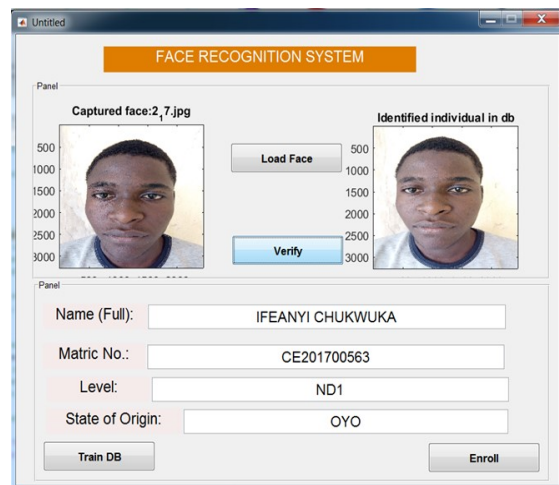

Figure 4: Correctly recognized Face

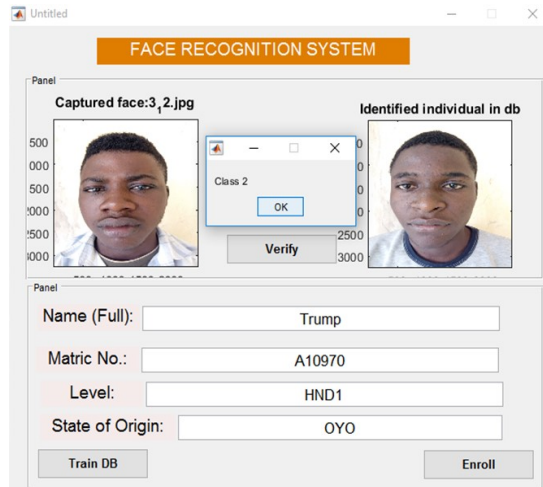

Figure 5: Wrongly recognisedf Face

Summary of the developed system performance evaluation is presented in Table 1. Fifty (50) faces each were used for testing the system from the two database. For white face database forty-seven (47) were correctly recognized and three (3) were wrongly recognized. The system was implemented on locally acquired black faces and forty-nine (49) faces were correctly recognized while one (1) is wrongly recognized. It was observed that the developed system achieved 94% and 98% recognition accuracy with white face database and locally acquired black face database respectively.

Table 1: Performance Summary of the Developed System

Metrics	Results (Locally Acquired Database)	Results (OUR Database)
Image size (Pixels)	50 × 50	50 × 50
True Positive (TP)	49	47
True Negative (TN)	0	0
False Positive (FP)	1	2
False Negative (FN)	0	1
Correctly Recognized	49	47
Incorrectly Recognized	1	3
Recognition Accuracy (%)	98	94

Some of the existing algorithms adopted by different researchers that revealed the year and results obtained are presented in Table 2. The results were compared with the

developed system result and it can be deduced that the system performed better.

Table 2: Comparison of existing results with developed system result

S/N	Authour	Algorithm Used	Result Obtained
1	Maha (2005)	2D Discrete Cosine Transform (2D-DCT) and Principal Component Analysis (PCA)	96.5%.
2	Jawad, Syed, and Farrukh (2008)	Neural Networks	81.36%
3	Surya and Pritee (2012)	Discrete Cosine Transform and Nearest Neighbor Discriminant Analysis	98.5%
4	Zahraddeen, Fatma, Abdulganiyu and Mustafa (2016)	Discrete Cosine Transform	93.4%
5	Developed Real Time Face Recognition System based on Pattern Matching	Principal Component Analysis and Euclidean Distance	94% (OUR database) 98% (Local database)

5 CONCLUSION

The results obtained by implementing the the pattern matching face recognition system on both white and black faces show that the system is reliable and can be adopted at any access control point. The pattern matching face recognition system can also be used to improve security in term of verification.

REFERENCES

- [1] J. F. Hair, G. T. Hult, and M. C. M. Ringle, *A primer on partial least squares structural equation modeling*, Second Edi. Los Angeles: SAGE Publications, Inc., 2017.
- [2] S. A. O. S.A. Aduloju, A.L. Awoponle, "Recapitalization, mergers, and acquisitions of the Nigerian insurance industry," *J. Risk Financ.*, vol. 9, no. 5, pp. 449–466, 2008.
- [3] R. H. McGuckin, "On productivity and plant ownership change: New evidence from the longitudinal research database," *RAND J. Econ.*, vol. 26, no. 2, pp. 257–276, 1995.

- [4] B. E. H. A. N. Kim and V. Singal, "Mergers and Market Power: Evidence from the airline industry," *Am. Econ. Assoc.*, vol. 83, no. 3, pp. 549–569, 1993.
- [5] T. C. and M. J. Piskorski, "Power imbalance, mutual dependence, and constraint absorption: A closer look at resource dependence theory," *Sage Publ. Inc.*, vol. 50, no. 2, pp. 167–199, 2005.
- [6] J. Pfeffer, "Size and composition of corporate boards of directors: The organization and its environment," *Sage Publ. Inc.*, vol. 17, no. 2, pp. 218–228, 1972.
- [7] O. Williamson, *The economic institutions of capitalism*, First. New York: The Free Press, 1985.
- [8] David R. King and R. J. S. and I. Kesner, "Intensive firms performance implications of firm resource interactions in the acquisition of R & D-intensive firms," *INFORMS*, vol. 19, no. 2, pp. 327–340, 2008.
- [9] J. P. Antony and S. Bhattacharyya, "Measuring organizational performance and organizational excellence of SMEs – Part 1: A conceptual framework," *Meas. Bus. Excell.*, vol. 14, no. 2, pp. 3–11, 2010.
- [10] J. Hales, *Accounting and financial analysis in the hospitality industry*. New York: Butterworth-Heinemann, 2005.
- [11] A. AbdulRasheed, I. S. Babaita, and M. A. Yinusa, "Fraud and its implication for bank performance in Nigeria," *Int. J. Asian Soc. Sci.*, vol. 2, no. 4, pp. 382–387, 2012.
- [12] H. Fauzi, "The Performance Implications of Fit among Environment, Strategy, Structure, Control System and Social Performance," *Issues Soc. Environ. Account.*, vol. 3, no. 2, pp. 117–142, 2010.
- [13] R. Simons, *Performance Measurement and Control Systems for Implementing Strategy Text and Cases*, Fourth. New Jersey, USA: Pearson education limited, 2013.
- [14] Z. Hoque, "A contingency model of the association between strategy, environmental uncertainty and performance measurement: Impact on organizational performance," *Int. Bus. Rev.*, vol. 13, no. 4, pp. 485–502, 2004.
- [15] J. F. Henri, "Performance measurement and organizational effectiveness: Bridging the gap," *Manag. Financ.*, vol. 30, no. 6, pp. 93–123, 2004.
- [16] A. Neely, *Business Performance Measurement; Unifying theories and integrating practice*, Second. New York: Cambridge University Press, 2007.

Gender Classification based on Local Binary Pattern and K-Nearest Neighbour

Temilola M. Adepoju¹, Matthias O. Oladele¹, Adebajo Adekiigbe² and Oluwatobi A. Ayofe¹

¹Department of Computer Engineering Technology, Federal Polytechnic Ede, Osun State Nigeria

²Department of Computer Science, Federal Polytechnic Ede, Osun State Nigeria

*atemilola@gmail.com

Abstract—Gender recognition from face image is a research area in the field of pattern recognition that determines gender based on biometric features of the face. Research has shown that the disparity between facial masculinity and femininity can be utilized to improve performances of face recognition applications in biometrics, human-computer interaction, and surveillance and computer vision. There is need to develop a gender classification system for human-computer interaction that recognizes the gender of an individual through the input face image. Hence, this study developed a facial gender recognition system using K-Nearest Neighbour (KNN). Facial images from the FERET database were obtained from the internet. The image database is made up of several images of male and female faces which have been categorized based on gender. These databases contain images of different poses for each individual. Local Binary pattern (LBP) was used to extract features of the images and the images were classified using K-Nearest Neighbour algorithm. The system was implemented using Matrix Laboratory 8.1 (MATLAB 2015a). The classification results showed that highest accuracy of 92% was achieved. The system could be adopted in classifying face images into male or female which is required in security control system or any other related systems.

Keyword— Feature extraction, Gender, Human Computer interaction, K-Nearest Neighbour algorithm Local Binary pattern (LBP) face classification, training and testing

1 INTRODUCTION

Gender classification has become an area of extensive research due to its increasing application in the existing Human-Computer Interaction (HCI) system such as gender detection, face recognition, body tracking, ethnicity identification, security industry, collecting demographics, and psychology among others (Muhammad, Sheraz and Naveed, 2013). Gender classification aimed at designating an image of a person into one of the categories of male or female. Precise image -based gender classification could have central value in Human-Computer Interaction HCI (Rodrigo, Javier and Mauricio, 2006). Gender classification is also a useful pre-processing step for face recognition since it is possible to have a case of equal amount of both genders, separating both genders before the recognition process can make the process almost twice as fast.

The face is the most significant component of the human body that are normally used by humans to recognize each other; thus, facial images are the most common biometric characteristics used for human verification and identification. Facial images have gained its importance due to its use in various aspects of life such as in airports, law enforcement applications and security systems. Face detection acts as a pre- processing step for gender classification that determines the gender of an individual. The detection of regularities and affinities in different parameters of a dataset serves as a useful tool for decision making and drawing predictions (Muhammad *et al.*, 2013).

Some works had been done in the field of gender

determination; some of these works are summarized in this section. Bing *et al.*, (2011) proposed a novel gender classification framework, which utilizes not only facial features but also external information, i.e. hair and clothing. Instead of using the whole face, five facial components such as forehead, eyes, nose, mouth and chin were used, also, a feature extraction method for hair and clothing was designed; these features have seldom been used in previous work because of their large variability.

For each type of feature, a single support vector machine classifier was trained with probabilistic output. The outputs of these classifiers are combined using various strategies, namely fuzzy integral, maximal, sum, voting and product rule. The major contributions of this paper were the investigation of the gender discriminative ability of clothing information and using facial components instead of the whole face to obtain higher robustness for occlusions and noise. Furthermore, hair and clothing information were exploited to facilitate gender classification. Experimental results showed that the proposed framework improves classification accuracy, even when images contain occlusions, noise, and illumination changes were used.

Rutuja and Shelke, (2015) presented a novel face detection and gender determination strategy in color images under non uniform background which uses features of the lip and the mouth region. This was done by detecting the human skin regions in image given and detecting facial features based on the measurements in pixels. The proposed method converted the RGB image into the YCbCr

color space to detect the skin regions in the facial image. But in order to detect lips and mouth features, the colour images were converted into gray scale image. Here, feature extraction was carried out by using Principal component analysis (PCA) and Gabor wavelet. The results using a training database of 15 male and 15 female images show an average performance of 88.6% correct gender determination on images from test set.

Hadeel and Mohamed, (2013), also presented a technique for gender determination using eye images, the proposed technique consists of several steps cropping the eye area from the image, applying 2D-Wavelet Transform, Gray Level Co-occurrence Matrix and Discrete Cosine Transform feature extraction algorithms. Finally, support vector machine was used for the feature classification. The proposed method obtained accuracy rate of 99.49 % on gender recognition using 2D-Wavelet Transform, accuracy rate of 98.49 % on gender recognition using GLCM and 99.62 % with DCT on Faces94 database.

Saatci and Town (2006) experimented with a SVM that was trained with the features extracted by an Active Appearance Model (AAM). They had a two phase classifier. First the expression of the face was classified (categories: happy, sad, angry, neutral, and unrecognized). Then a gender classifier that was specific to the expression was used to recognize gender. This way they aimed to improve gender classification rate. However, the gender classification rate was decreased although they were able to improve facial expression classification rates by having separate expression classifiers for both genders. They suggested that the reason for the decrease in gender classification task was in the small amount of training images.

Anushri, Asif and Bhupesh, (2013) also presented a novel method to gender classification using a new simple feature extraction which extracts geometric features such as distance between eyebrow to eye, eyebrow to nose top, nose top to mouth, eye to mouth, left eye to right eye, width of nose, width of mouth. Viola Jones and Artificial Neural Network algorithms were used for feature extraction.

The features set was applied to three different applications: face recognition, facial expressions recognition and gender classification, which produced the reasonable results in all database. These features provide input to trained neural networks. The neural networks were also used for classification purpose. The networks have been trained to produce value 1 for male and 0 for female. Output of these neural networks determined the gender of the person. The results using training database of 100 male and 100 female images shows that SVM has an accuracy of 76.82% while Threshold Adaboost has an accuracy of 75.26%, a combination of LBP and SVM gave an accuracy of 81.45 % while ANN showed the best accuracy of 98.40%.

Ramin, Robert, Won-Sook and Daniel, (2015) pre-

sented a complete framework for video-based age and gender classification which performs accurately on embedded systems in real-time and under unconstrained conditions. A segmental dimensionality reduction technique using Enhanced Discriminant Analysis (EDA) was used to reduce the memory requirements up to 99.5%. A non-linear Support Vector Machine (SVM) along with a discriminative demographics classification strategy was also exploited to improve both accuracy and performance of the gender classification system.

Research has shown that the disparity between facial masculinity and femininity can be utilized to improve performances of face recognition applications in biometrics, human-computer interaction, surveillance and computer vision. However, in a real-world environment, the challenge is how to deal with the facial image being affected by the variance in factors such as illumination, pose, facial expression, occlusion, background information and noise. This is then also the challenge to the development of a robust face-based gender classification system that has high classification accuracy. Hence, there is need to develop a gender determination system using Bayesian classifier to distinguish between male and female.

2 METHODOLOGY

The block diagram of the gender recognition system is shown in figure 1. Face images were acquired online from the FERET database and the images were divided into two: training and testing. One hundred images were used for training (50 males and 50 female) and 50 images were used for testing (25 males and 25 female). The features were extracted using Local Binary Pattern and KNN was used to classify the images into either male or female.

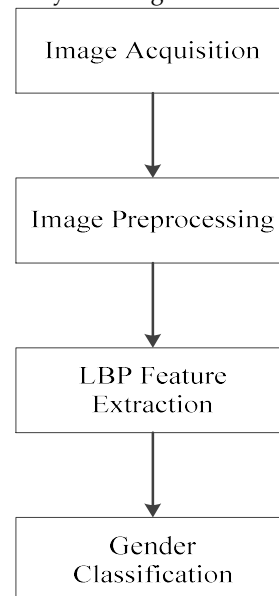

Figure 1: Block diagram of the gender recognition system
Data Acquisition

Facial images used to train and test the system was retrieved from the FERET database. A total of 150 images were used to train and evaluate the performance of the developed system. One hundred images were used for training and fifty images for testing.

Image Preprocessing

Image preprocessing helps to enhance the quality of the facial images, to improve its visual appearance and to further convert the image to a form better suited for gender classification. The preprocessing stages that was used for the developed system are image resizing, gray-scale conversion and image enhancement.

Image Resizing: This was carried out to confirm uniformity of the facial images to be used; all the images were scaled to a uniform size. The images were resized to 100 × 100 pixels for the developed system. The *imresize* MATLAB function was used to resize the image.

Grayscale Conversion: The images retrieved from the online database were all coloured images. Coloured images increases processing time because of the size, also some relevant features may be hidden from coloured images, hence there is need to convert the coloured images to grayscale. The *rgb2gray* MATLAB function was used to convert the coloured images to gray images.

Image Enhancement: Image enhancement techniques help to highlight certain features of interest in an image. Histogram equalization was used for image enhancement. Histogram equalization is a spatial domain method that produces output image with uniform distribution of pixel intensity means that the histogram of the output image is flattened and extended systematically. Histogram equalization usually increases the global contrast of the processing image. The MATLAB function used was the *histeq*. Figure 2(a) and (b) shows an input image with the histogram before and after enhancement while Figure 3 and 4 shows the graphical representation of the histogram images.

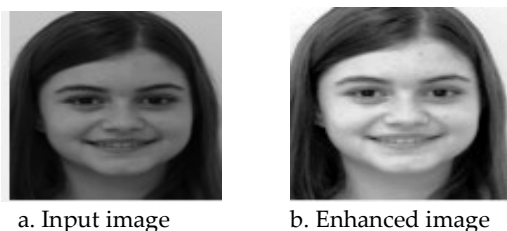

Figure 2: Input image before (a) and after enhancement (b)

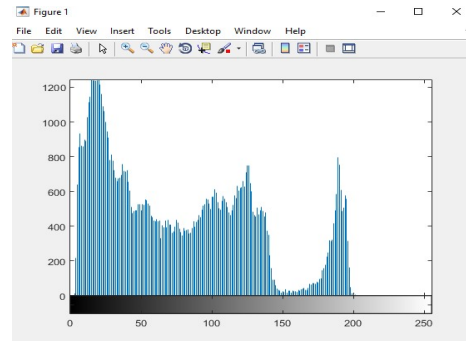

Figure 3: Histogram before enhancement

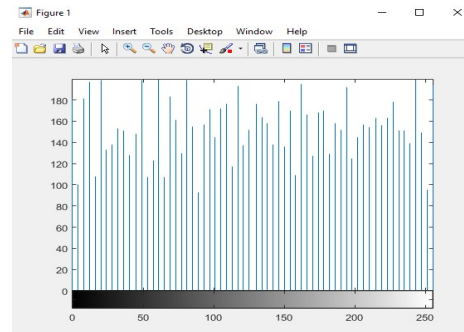

Figure 4: Histogram after enhancement

Feature Extraction

In the feature extraction stage, relevant features needed for recognition was extracted from each face image. The feature extraction used was the Local Binary Pattern (LBP). LBP was used to extract the texture characteristics of the face images. Using the LBP operator, the face image was divided into 3 × 3 and the local binary pattern histograms were computed and concatenated into a single histogram. The texture of the facial regions was encoded by the LBP while the shape of the face is recovered by the concatenation of different local histograms.

Classification

KNN classifier was used to classify the face images into either male or female. The classification is divided into training stage and testing stage. For the training stage, a KNN model was constructed from the training images and finds relationships between the predictors and targets. The testing stage tests the KNN model on a test sample whose class labels are known but not used for training the model. Figure 5 (a) and (b) shows the training and testing stages.

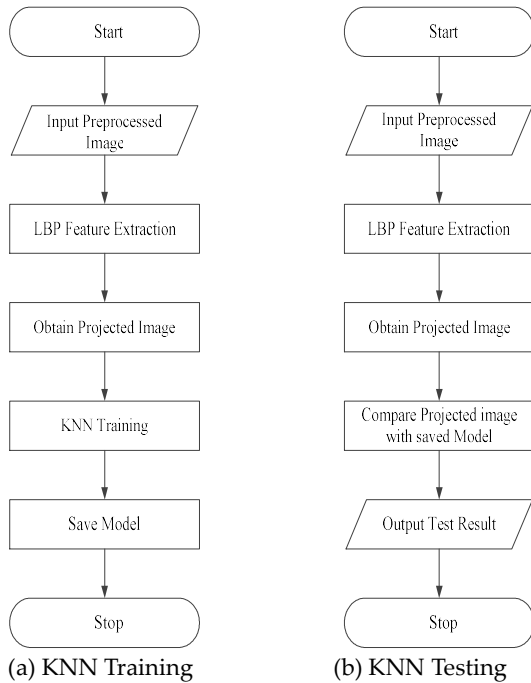

Figure 5: Training and testing stages

3 RESULT DISCUSSION

The results obtained from the KNN classification with a training sample of 100 images and testing sample of 50 images showed a training time of 3.396974 seconds and testing time of 4.162747 seconds. The value of K was varied between 2 to 10 and the result gotten was shown in Table 1. It was observed that the highest accuracy was 92% at K = 9 was obtained. Figure 6 represent correct classification of a female, figure 7 depicts correct classification of a male while figure 8 shows a male misclassified as a female.

K	TP	TN	FP	FN	CC	IC	ACC (%)
2	20	21	5	4	41	9	82
3	19	22	6	3	41	9	82
4	19	22	6	3	41	9	82
5	19	23	6	2	42	8	84
6	21	22	4	3	43	7	86
7	21	24	4	1	45	5	90
8	20	23	5	2	43	7	86
9	21	25	4	0	46	4	92
10	20	24	5	1	44	6	88

Table 1: Results of the developed system

Where TP = True Positive
 TN = True Negative
 FP = False Positive
 FN = False Negative
 CC = Correctly Classified
 IC = Incorrectly Classified

ACC = Accuracy

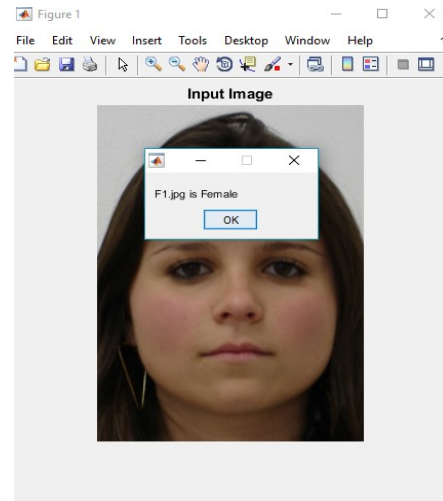

Figure 6: Correctly classified Female face

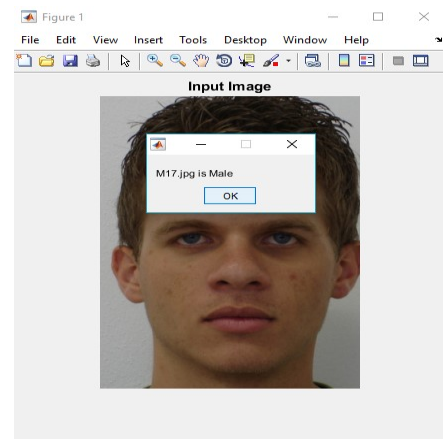

Figure 7: Correctly classified male face

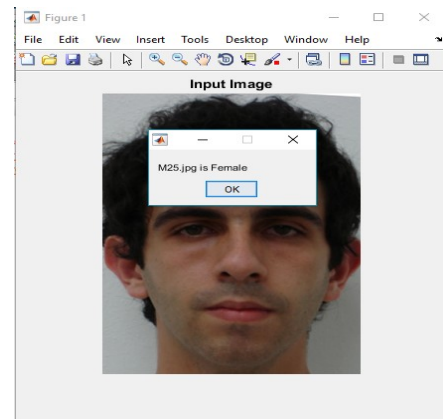

Figure 8: Incorrectly classified male face classified as female

4 CONCLUSION

A gender recognition system to discriminate gender from face images, with an improved accuracy was developed. An accuracy of 92% was achieved from the study

which shows that the system is reliable and can be used for gender classification in any human computer interaction field. This can assist as a security measure and access control unit and hospitals.

REFERENCES

- [1] Anushri Jaswante, Asif Ullah Khan and Bhupesh Gour (2013), "Gender Classification Technique Based on Facial Features using Neural Network", *International Journal of Computer Science and Information Technologies*, Vol. 4, No. 6, Pp. 839-843.
- [2] Bing, Li, Xiao-Chen Lian, Bao-Liang Lu (2011): "Gender Classification by Combining Clothing, Hair and Facial Component Classifiers", *Neurocomputing*, doi: 10.1016/j.neucom.2011.01.028.
- [3] Hadeel Fahad Alrashed and Mohamed Abdou Berbar (2013), "Facial Gender Recognition Using Eyes Images", *International Journal of Advanced Research in Computer and Communication Engineering* Vol. 2, Issue 6, Pp. 2441-2445.
- [4] Muhammad Naeem, Ahmed Khan, Sheraz Ahmed Qureshi and Naveed Riaz (2013), "Gender Classification with Decision Trees", *International Journal of Signal Processing, Image Processing and Pattern Recognition*, Vol. 6, No. 1, Pg. 165-176.
- [5] Rodrigo Verschae, Javier Ruiz-del-Solar and Mauricio Correa, "Gender Classification of Faces Using daboost", *Progress in Pattern Recognition, Image Analysis and Applications*, vol.42, Issue 26, (2006), Pp.68-78.
- [6] Ramin Azarmehr, Robert Laganieri, Won-Sook Lee Christina Xu, Daniel Laroche (2015), "Real-time Embedded Age and Gender Classification in Unconstrained Video", *Proceedings of IEEE computer vision workshop* 2015.
- [7] Rutuja G. Shelke, Annadate S. A. (2015), "Face Recognition & Gender Determination Using LIPS", *International Journal of Advance Foundation and Research in Computer (IJAFRC)* Volume 2, Special Issue (NCRTIT 2015), January 2015. ISSN 2348 – 4853.
- [8] Saatci Y. and Town. C. (2006), Cascaded classification of gender and facial expression using active appearance models", *In: Proc. 7th Internat. Conf. On Automatic Face and Gesture Recognition (FGR'06)*, Pp. 393-400

From Smell Phenomenon to Smell Agent Optimization (SAO): A Feasibility Study

Ahmed T. Salawudeen¹, Muhammed B. Mu'azu¹, Yusuf A. Sha'aban^{1,2} and Emmanuel A. Adedokun¹

¹Department of Computer Engineering, Ahmadu Bello University, Zaria, Kaduna, Nigeria.

²Centre for African Studies, Massachusetts Institute of Technology, Cambridge, USA.

*tasalawudeen@abu.edu.ng

Abstract—This paper presents a feasibility study, towards the development of a novel computational intelligent algorithm using the phenomenon of smell. According to literature, depending on the olfactory size of an organism (agent) and psychological condition, every living organism has a specific ability to perceive smell molecules (olfaction) and intuitively trail these molecules until its source is identified. Using this idea, this paper presents the possibility of developing a novel computational Intelligent algorithm called the Smell Agent Optimization (SAO). The idea of the SAO will be based on the evaporation of smell molecules in the form of gas and the perception capability of a smell agent. The mathematical model of the SAO will consist of three modes (Sniffing mode, Tailing mode and Random mode). When developed, the algorithm is expected to compete favorably with already established algorithm like ABC, GA, PSO etc.

Keyword—Smell Agent Optimization (SAO); Smell Molecules; Sniffing Mode; Trailing Mode; Random Mode.

2 INTRODUCTION

Attempt to adopt an acceptable definition of intelligence still elicit debates among various disciplines. Dictionaries [1], [2] have defined intelligence as the power of understanding, comprehending and profiting from experience, the power to interpret and having the capability for thought and reason especially to a high degree. The mechanisms of this intelligence, which are exhibited by all living systems, share similarities in terms of complexity, organization, and adaptability as a whole. Over the years, experts have understandably sought for means of codifying these intelligence systems into algorithms dedicated to solving some complex problems in engineering and related disciplines. This triggered the development of a new field of study called computational intelligence (CI) which was popularized by James C. Bezdek about 23 years ago [3]. Perhaps, the first appearance of CI was way back in 1983 when the term international Journal of Computational Intelligence (IJCI) was reported to be the title of the Canadian journal by its editors and founders Gordon McCalla and Nick Cercone [5], [6] stated that computational intelligence consists of any science supported approaches and technologies for analyzing, creating, and developing intelligent systems. Intelligent in this case refers to the utilization of engineering techniques that have, to one extent or another, been borne out of human reasoning, adaptation or learning, biological cognitive structures or principles of evolution, natural physical or chemical processes. Many experts have also referred to the term computational intelligence (CI) as the ability of a computer system to learn precisely a specific task, from a given set of data and/or empirical observation [7]. The IEEE Neural Network Council and the IEEE World Congress on Computational Intelligence formalized this term in the sum-

mer of 1994 in Orlando, Florida [8]. Till, date, researchers have not come to a conclusive agreement as to a precise definition of computational intelligence [9]. This is because it is difficult to start with anything precise; the precision has to be achieved through a certain process. But, strictly speaking, computational intelligence is a set of nature-inspired computational models and approaches capable of addressing real-world problems to which traditional or mathematical model may fail due to any or all of the following reasons:

- I. The problem or process may be too complex for mathematical reasoning.
- II. The problem or process may be dynamic and stochastic in nature.
- III. The solution space of the problem may be too large for mathematical computation.
- IV. The problem or process may contain some uncertainties.

All these characteristics are exhibited by most real life (non-linear) science, economic, social and engineering problems. These non-linear type problems require several assumptions in order to transform them to their near-linear equivalents for easy computation. However, the outputs of such linear computations usually do not depict entirely the real-life situations. Therefore, agent-based computational intelligent techniques are capable of providing superb and promising alternatives in this scenario. In the past decades, researchers have developed various agent-based biological and nature-inspired CI algorithms for solving various optimization problems. The foraging behaviors of ant systems were codified into an algorithm in [10]. Algorithms based on the intelligent behaviour of fish [11], bacterial foraging [12], Firefly [13],

swarm particles [14], bee [15], Brownian motion of gas [16], fruit fly [17], shark smell [18] etc. have also been developed. The performance of all these algorithms on suitable problems such as in [19], [20], [21], [22], [23] has demonstrated their effectiveness in solving real world problems. It is, however, important to note that, there is no known single nature-inspired optimization method available for solving all optimization problems (which is called the no free lunch theorem). This is because every real world problem can directly or indirectly be formulated as a solution using a particular algorithm that mimics a nature or bio-inspired phenomena.

For example, the pheromone trail and pattern movement of ant system can be said to mimic the lane and edge detection problem in transportation and image processing respectively. Similarly, the path planning and trajectory problem of a robot can be linked to an agent seeking to identify the molecular movement of an object (smell) which evaporates and travels into the olfactory organ (nose) of an agent, where they activate special cells that send a message to the brain for adequate judgment. Thus, this paper seeks to study the feasibility of codifying the intuitive movement of an agent towards smell (odorant) molecule as the agent seeks to identify the source of that smell or odorant. One of the five senses through which the world is perceived is the sense of smell (olfactory). Through the sense of smell, humans and other animals can perceive a large number and varieties of chemicals in the external world [24]. In fact, with a good sense of smell, humans and other agents (especially dogs) can perceive the molecular concentration of smell and intuitively trace or follow this concentration in order to identify its source.

This is possible because the nose has a mechanism that can recognize sensory information within its surroundings and transmit the information to the brain, where it is processed to simulate internal representation of the external world [25]. These representations help the smell agent to determine the optimized path which constitutes the search or solution space. In this case, the object which radiates the odor molecule is the solution that resides in the search space. Based on this, this paper hopes to provide detail information which enables the development of an optimization algorithm using the path trailing ability of smell agents for solving various degrees of combinatorial optimization problems. In virtually all optimization problems, the complexity and structure of the problems increase as the dimension of the problem increase. In such situations, an exhaustive search is not feasible. Thus, a technique capable of operating in a domain of such optimization problems in which a set of possible solution is discrete or can be reduced to discrete with a common goal of finding the best solution is termed combinatorial optimization. Combinatorial optimization is an indication of optimization problems with an extremely large (combinatorial) increase in the number of possible solutions as the problem size

increases.

2 MATERIALS AND METHODS

In this section, the fundamental theory which support the modeling of the smell agent optimization are provided. When necessary, readers are also referred to relevant literatures for further study.

2.1 Phenomenon of Smell (Olfaction)

Full Smell is defined as the ability to perceive the odour or scent of something through the nose by means of the olfactory nerves [2]. This are usually, made of chemical compound of different molecules evaporating from a source with a molecular weight of less than 300 Dalton [26]. Detection and discrimination of this chemicals in the environment are critical for the survival of most organisms. Virtually, all organisms ranging from the simplest unicellular form to the most advanced multicellular creature possess the capability to detect chemicals in their surroundings through a process called chemosensation [27]. Chemosensation relies on the olfactory systems which contain a large number of chemoreceptors used by organisms to locate food, mates and avoiding danger. These chemoreceptors are generally classified into odorant receptors and pheromone receptors which principally detect general odours and pheromones respectively [28]. The chemical compounds which are odour molecules travels into the nasal cavity, where they are detected by the olfactory receptors. At this point, the olfactory receptor neuron fires and transmits an impulse into the olfactory bulb at the top of the nasal passage.

This connects to the olfactory centre in the cerebral cortex for odour perception and recognition and to the limbic system which controls the expression of emotion and instinctive behaviors. Researchers have estimated about five to six million olfactory receptors in man, each having a specific sensation for a particular ligand (ligand in this case refers to a specific sensation for a particular smell molecule). This enables man to be able to detect over one trillion different odours [30]. It is however believed that each odorant molecules triggers several olfactory receptors which create a unique combination of neural impulses that is interpreted as a single odour scent. An interesting thing to note is that, despite the olfaction capability of man, agents such as dogs, rabbits etc. have a stronger olfaction capacity. For example, dogs have been said to have over 220 million olfactory receptors which account for their dazzling sense of smell [24]. As an illustration, Fig.1(a) and Fig.1(b) show the biological structures of the olfactory systems in man and dog respectively [24], [31]. The chemosensation process of the agents shown in Fig. 1, and in fact every which has the faculty of olfaction, follows the same process highlighted as follows:

I. Evaporation

- II. Stimulation
- III. Transduction
- IV. Transmission

V. Interpretation

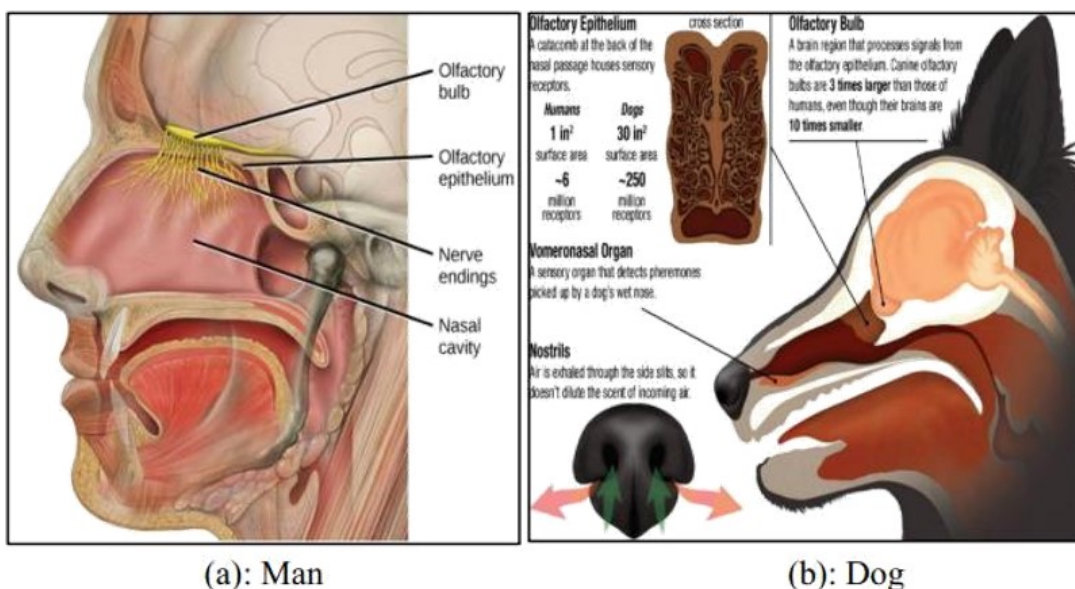

Figure 1. Olfactory System

At the evaporation stage, the molecular vibration of an object which has smell capabilities evaporates chemical compound which travels into an agent nasal cavity at a molecular weight of less than 300 Dalton. At the stimulation stage, the chemical compound interferes with the nerve endings of the olfactory epithelium which generates a specific stimulating energy for the chemical compound. An electrochemical (chemosensation) nerve impulse is therefore produced by the olfactory receptors through transduction. The electrochemical impulse is then transmitted through action potential along different pathways into the brain. The brain then interprets and creates perception from the electrochemical event produced by stimulation. This action of the brain is what an agent perceives as the smell.

From the perspective of chemistry, smell (odor or fragrance) is generated by one or more chemical compounds generally at a very low concentration that humans or agents can perceive through olfaction [30]. Smell and taste are the chemical sense indicators of every agent as they allow an agent to be aware of the presence of chemical substances in their environments. The ability to detect these substances is predicated on the chemical nature of their molecules [28], [32] and the vibration of this molecules. Chemists have over the years identified that atoms in a molecule vibrate at a particular frequency depending on their overall molecular structure. In fact, a single change of atom in the molecular structure can make the smell molecules to vibrate at a much higher frequency resulting in variation of smell perception [29]. This accounts for why

smell molecules of a very close structure and mass differs in terms of perception. For example, the fragrance (smell) of wintergreen which is used predominantly in mints, candies, mouthwashes, and toothpaste has the same molecular structure with vanilla fragrance (smell) which is used to make ice cream and chocolate. The molecular formula of the wintergreen is $C_8H_8O_3$ and the molecular structure is shown in Fig.2 while the molecular formula of vanilla is also $C_8H_8O_3$ and its molecular structure is as shown in Fig.3 respectively [32].

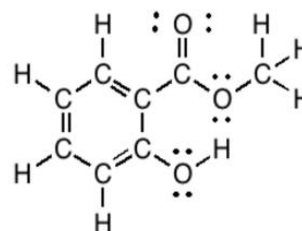

Figure 2. Molecular Structure of Methyl Salicylate (Wintergreen) [34]

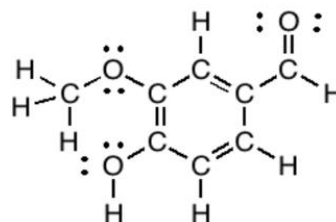

Figure 3. Molecular Structure of Vanillin (Vanilla) [34]

From, Fig.2 and Fig.3, it can be observed that, though both wintergreen and vanilla have the same molecular formula and structure, the variation in their fragrance are attributed to the positioning and bonding of the functional group which in this case is an ester and aldehyde respectively. Detail characteristics of this functional group are beyond the scope of this paper. However, readers who are interested in this information can refer to [33], [34]. For a smell molecule to be perceptible by an agent, the chemical composition of the smell has to be lipophilic, small (with a molecular weight of less than 300 Da) and volatile [34]. Of interest in this research is the molecular mass (weight) of the smell particles and because the particles are individually very small (in terms of weight and size), their initial situations and states of motion are not known. Even if this is known, there is an unequal power to the task of following the subsequent motion of all the individual smell molecules [35]. Thus, the faith of individual smell molecules will not be the focus of the proposed smell agent optimization (SAO) algorithm but, on the collective distribution of properties and motion (diffusion) of these smell molecules. Fig.4 shows a typical random movement of a smell molecule. It can be

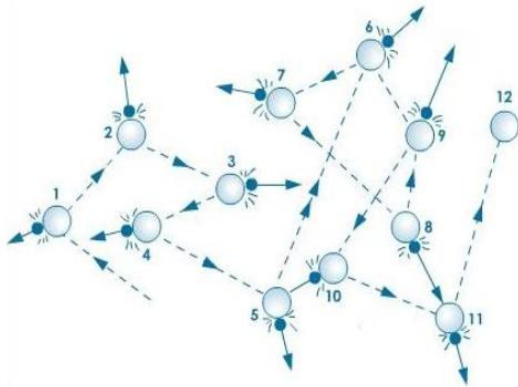

Figure 4. Random Movement of smell Molecule

observed from Figure 2 that, point 1 shows the initial position of the gas molecule. The molecule moves through all the other point until the destination point 12, in a Brownian form. The path followed by the gas molecule can thus be deduced as in Fig

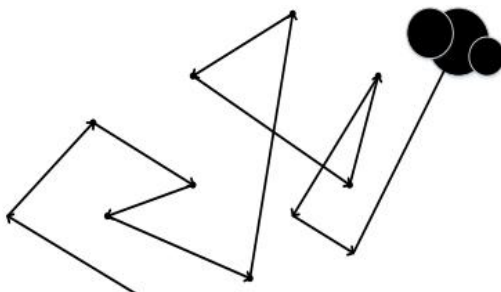

Figure 5. Smell Molecule Path Illustration

Trailing the path of the smell molecule shown in Fig.5 is usually the main focus of all smell agents. By this, virtually all organisms are aware of the presence of chemical substances in their environments and ensure their survival.

3 SMELL AGENT OPTIMIZATION (SAO)

Every biologically inspired optimization algorithms are usually based on a number of critical modeling parameters. These parameters are usually decided through careful observation and understanding of the biological system on which the algorithm is inspired. In order to develop an algorithm which is inspired by the phenomenon of smell, the Brownian movement of the smell molecules towards the agent, the training movement of the agent towards the molecule should be considered. Thus, the following mode for the algorithm can be modeled.

- a. The gaseous molecules of smell evaporate in the direction of the Smell Agent (SA). This is termed the sniffing mode.
- b. The SA trailing the part of the gaseous molecules smell and eventually identify it source. This is termed the trailing mode.
- c. In a situation where the agent loss its trail during the search, a position is selected randomly and the agent move towards this position hoping to sniff the smell molecule again. This is termed the random mode.

3.1 Sniffing Mode

In a practical situation, the agent should be able to sniff the smell particles and intuitively follow this particle with the hope of identifying its source. This usually because the agent, due to variation in the temperature and molecular mass of the smell particles, making part trailing a challenging task. While exploring the search space, the concentration of smell molecules may become higher than the current position of the agent, in this case, the agent moves towards this position. This way, the agent continues to trail the position of all molecule with higher concentration until the molecule with the overall best fitness (smell source) is identified. This behavior of the agent would be model as the sniffing mode in smell agent optimization.

The process of SAO is initiated by a randomly generated initial position (population) of smell molecules. The size of the population depends on the total number of molecules of smell evaporating from the smell source. Assuming the smell molecule is denoted as N and the hyperspace where the smell molecule is evaporating is denoted as D , then, the population of the smell molecules will be assigned a position as

$$X'_i = [X'_{N,1}, X'_{N,2}, \dots, X'_{N,D}] \quad (1)$$

where $\{i = 1, 2, \dots, N\}$, t is the present position of a smell molecule. The position vector in eq.1 enables the agent to determine the region with the highest concentration in the search space. For example, consider the coordinate positions given in Fig.6 3. Each cycle in the cell depicts a molecule of smell. The number of columns in the figure represents the dimension (D) or solution search space to be explored while the number of rows represents the population of the smell molecule exploiting the search space. From Fig.6, if N is 3 and the index of the molecule with the highest concentration

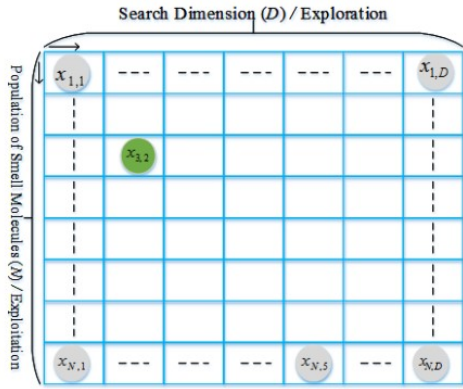

Figure 6. Smell Position in Hyperspace

is $x_{3,2}$, this indicates that the smell molecule with the highest concentration, in this case, is at the coordinate (3,2) of the entire search space indicated as a circle with green color. Since the smell molecule evaporates and travels through the air in the direction of the agent, each molecule can be said to maintain a uniform velocity in the direction of the agent, provided the intensity of the air medium is constant. This movement velocity of the smell molecule is denoted as V . The velocity-vector V is the diffusion vector (which is a displacement of the smell molecule from the smell source/origin). Thus, the position of the smell molecules considering the velocity vector will be given as

$$X_i^{t+1} = X_i^t + V_i^t \tag{2}$$

Since every smell molecules will their corresponding velocities for which they move and update their position in the search space. The preliminary theory of molecules movement and the heuristic derivation of the velocity distribution function given by Maxwell in [36] will be used to develop the velocity update model

3.2 Trailing Mode

While exploring the search space, the concentration of a smell molecules may become higher than the current position of the agent, in this case, the agent moves to-

wards this position. This way, the agent continues to trail the position of all molecule with higher concentration until the molecule with the overall best fitness (smell source) is identified. In practical situation, the agent should be able to sniff the smell particles and intuitively follow this particle with the hope of identifying its source. This usually because the agent, due to variation in the temperature and molecular mass of the smell particles, making part trailing a challenging task. Also, every agent has a specific capacity of olfaction, depending on their size of olfactory lobe, psychological and physical condition. For example, larger size of olfactory lobe indicates a stronger olfaction which favors exploitation while smaller size of olfactory lobe indicates poor olfaction which is an indication of poor exploration. Since the proposed SAO is generalized for all agent, the SAO precision and convergence will obviously be influenced by the olfaction capacity of the agent. This behavior of the agent would be model as the trailing mode in smell agent optimization. The conceptual framework of the SAO is given in Fig.7.

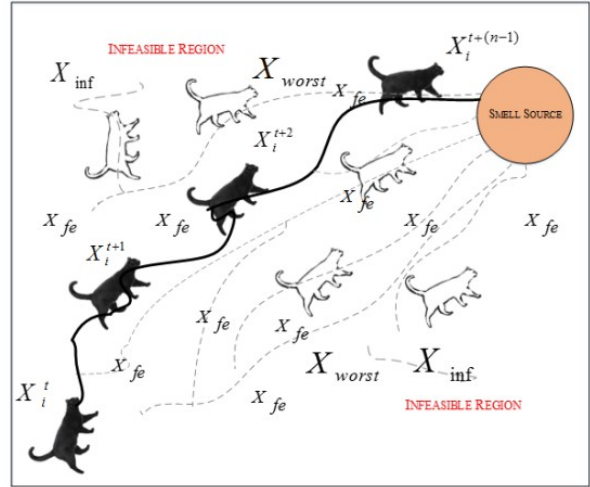

Figure 7. Smell Position in Hyperspace

In Fig.7., the agent is represented as a cat and the object evaporating the smell molecule is depicted in the grey circle. The dotted lines (labeled X) denote the direction of the evaporation of the smell molecules while the thick line represents the path with a high concentration of smell (optimum path). The paths labeled X_{fe} are all feasible paths (path with lower smell concentration) which if followed could lead the agent to the smell source. However, the agent is usually restricted to follow only the optimum path all through the search process. At every stage in the searching process, the agent takes note of the X_{worst} position (feasible paths in a generation) and makes use of this information to restrict its movement within the optimum path. This ideology will be modeled in the trailing mode search equation. The path labeled X_{inf} is an infeasible path, which leads the agent to an infeasible solution. The movement towards this region is avoided by appropriately selecting a suitable value for the SAO control parameters.

During the search process, the SAO identifies the region with high concentration of smell by performing the sniffing mode which represents the first position of the cat in Fig.7. The agent (cat) updates its position by performing the entire process of SAO and updating (iteratively) its position until the smell source is reached (optimum solution is obtained).

3.3 Random Mode

The smell molecules are discrete in nature if these molecules are separated by large distance apart in comparison with the molecular search dimension, the intensity/concentration of the smell molecule varied over time from one point to another. This bewilders the agent, and the agent may subsequently lose the smell, making the trail a challenge. At this point, the agent maybe trapped into local minimal leading to its inability to continue trailing. In the natural situation, the agent moves randomly within the smell perception region hoping to perceive the smell molecule again. This behavior of the agent will be model as the random mode in the smell agent optimization.

4. CONCLUSION

This report has presented a feasibility study towards the development of a novel Smell Agent Optimization (SAO) algorithm using the diffusion process of smell molecules and the trailing behaviours of an agent towards these molecules. The evaporation of smell molecules from the smell source and the Brownian motion of these molecules in the direction of the agent will be developed. Thereafter, the smell perception capability of the agent will be determined and the trailing behaviour of the agent towards the smell molecules as the agent seeks to identify the source of the smell will also be developed. In our future work, the SAO algorithm will be developed and its application to various combinatorial optimization problem will also be presented.

ACKNOWLEDGMENT

The authors wish to acknowledged the Nigerian Liquified Natural Gas (NLNG) for providing us access to the mechatronics axis of the multi-user laboratory ABU, Zaria where most of the study were carried out.

REFERENCES

[1] D. Crystal, *The Cambridge encyclopedia of the English language* (Emst Klett Sprachen), 2004
 [2] J. Simpson and E. S. Weiner, (1989), *Oxford English dictionary online*. Oxford: Clarendon Press. Retrieved March, 6, 2008.

[3] J. C. Bezdek, (1993). *Intelligence: Computational versus artificial*. IEEE Transactions on Neural Networks, 4(5), 737.
 [4] J. C. Bezdek, (2013). *The history, philosophy and development of computational intelligence* (How a simple tune became a monster hit). Computational intelligence. Oxford, UK: Eolss Publishers. Google Scholar.
 [5] M. B. Mu'azu, (2016) *Computational Intelligence: from the Tradition to the Inovative in Search for the Optimal Solution*, in Editor (Ed.) (Eds.): *Book Computational Intelligence: from the Tradition to the Inovative in Search for the Optimal Solution* (Ahmadu Bello University Press Limited, Zaria Kaduna State, 2016, edn.)
 [6] M. B. Mu'azu, (2006) *Forecasting and Modeling Statistical Phenomena using Neurofuzzy Logic: A Case Study of Rainfall Forecasting for Zaria*, Ahmadu Bello Univeristy, 2006
 [7] N. Siddique, and H. Adeli (2013). *Computational intelligence: syner-gies of fuzzy logic, neural networks and evolutionary computing*. John Wiley and Sons.
 [8] B. Xing, and W. J. Gao, (2016). *Innovative computational intelligence: a rough guide to 134 clever algorithms* (pp. 105-121). Springer.
 [9] H. J. Zimmermann, (1999, July). *From fuzzy set theory to compu-tational intelligence-special European experiences*. In *Intelligent Pro-cessing and Manufacturing of Materials, 1999. IPMM'99. Proceedings of the Second International Conference on* (Vol. 1, pp. 45-51). IEEE.
 [10] M. Dorigo, V. Maniezzo, and A. Colorni, (1996). *Ant system: optimization by a colony of cooperating agents*. IEEE Transactions on Systems, Man, and Cybernetics, Part B (Cybernetics), 26(1), 29-41.
 [11] X. L. Li, (2002). *An optimizing method based on autonomous ani-mats: fish-swarm algorithm*. Systems Engineering-Theory and Practice, 22(11), 32-38.
 [12] K. M. Passino, (2002). *Biomimicry of bacterial foraging for dis-tributed optimization and control*. IEEE control systems, 22(3), 52-67
 [13] X. S. Yang, (2010). *Firefly algorithm, stochastic test functions and design optimisation*. International Journal of Bio-Inspired Computa-tion, 2(2), 78-84.
 [14] R. Eberhart, and J. Kennedy, (1995). *A new optimizer using particle swarm theory*. In *Micro Machine and Human Science, 1995. MHS'95., Proceedings of the Sixth International Symposium on* (pp. 39-43). IEEE.
 [15] D. Karaboga, and B. Basturk, (2007). *A powerful and efficient algorithm for numerical function optimization: artificial bee colony (ABC) algorithm*. Journal of global optimization, 39(3), 459-471.
 [16] M. Abdechiri, M. R. Meybodi, and H. Bahrami, (2013). *Gases Brown-ian motion optimization: an algorithm*

- for optimization (GBMO). *Applied Soft Computing*, 13(5), 2932-2946.
- [17] W. T. Pan, (2012). A new fruit fly optimization algorithm: taking the financial distress model as an example. *Knowledge-Based Systems*, 26, 69-74.
- [18] O. Abedinia, N. Amjady, and A. Ghasemi, (2016). A new metaheuristic algorithm based on shark smell optimization. *Complexity*, 21(5), 97-116.
- [19] K. M. Sundaram, R. S. Kumar, C. Krishnakumar, and K. R. Suga-vanam, (2016). Fuzzy logic and firefly algorithm-based hybrid system for energy efficient operation of three phase induction motor drives. *Indian Journal of Science and Technology*, 9(1).
- [20] M. Pradhan, P. K. Roy, and T. Pal, (2016). Grey wolf optimization applied to economic load dispatch problems. *International Journal of Electrical Power and Energy Systems*, 83, 325-334.
- [21] S. A. Tijani, and M. B. Mua'zu, (2015, November). Stabilization of inverted pendulum system using intelligent Linear Quadratic Regulator controller. In *Computational Intelligence (IJCCI)*, 2015 7th International Joint Conference on (Vol. 1, pp. 325-333). IEEE.
- [22] K. Malarvizhi, and M. Kumar, (2015, February). Particle swarm optimization tuned BELBIC controller for 8/6 SRM operation. In *Electronics and Communication Systems (ICECS)*, 2015 2nd International Conference on (pp. 904-909). IEEE.
- [23] H. Turabieh, and S. Abdullah, (2011, January). A hybrid fish swarm optimisation algorithm for solving examination timetabling problems. In *International Conference on Learning and Intelligent Optimization* (pp. 539-551). Springer, Berlin, Heidelberg.
- [24] L. B. Buck, (2005). Unraveling the sense of smell (Nobel lecture). *Angewandte Chemie International Edition*, 44(38), 6128-6140.
- [25] R. Axel, (2005). Scents and sensibility: a molecular logic of olfactory perception (Nobel lecture). *Angewandte Chemie International Edition*, 44(38), 6110-6127.
- [26] J. E. Amoore, and E. Hautala, (1983). Odor as an aid to chemical safety: odor thresholds compared with threshold limit values and volatilities for 214 industrial chemicals in air and water dilution. *Journal of applied toxicology*, 3(6), 272-290.
- [27] S. Sookoian, A. Burgueo, T. F. Gianotti, G. Marillet, and C. J. Pirola, (2011). Odor perception between heterosexual partners: its association with depression, anxiety, and genetic variation in odorant receptor OR7D4. *Biological psychology*, 86(3), 153-157.
- [28] C. J. Wysocki, and G. K. Beauchamp, (1984). Ability to smell androstenone is genetically determined. *Proceedings of the National Academy of Sciences*, 81(15), 4899-4902.
- [29] C. Bushdid, M. O. Magnasco, L. B. Vosshall, and A. Keller, (2014). Humans can discriminate more than 1 trillion olfactory stimuli. *Science*, 343(6177), 1370-1372.
- [30] H. Breer, (2008). The sense of smell. *Annals of the New York Academy of Sciences*, 1126(1), 1-6.
- [31] G. M., Shepherd, (2004). The human sense of smell: are we better than we think? *PLoS biology*, 2(5), e146.
- [32] S. M. Black (2014), *Chemistry of Smell* (chem 1010), in Editor^ (Ed.) (Eds.): *Book Chemistry of Smell* (chem 1010) (Dixie State College of Utah, 2014, edn.).
- [33] Y. Huifeng, G. Lin, L. Shao-Chi, L. Xiangqian and R. Magnus, *Selective Reductive Removal of Ester and Amide Groups from Arenes and Heteroarenes through Nickel-Catalyzed C- O and C- N Bond Activation*, Volume 3, pp.3972-3976, Wiley Online Library, 2017.
- [34] L. Alexander, K. Steffen and G. Mathias and T. Andrea, *Gold-based catalyst for the oxidative esterification of aldehydes to obtain carboxylic esters*, Google Patents and US Patent App. 15/543,291, 2018.
- [35] C. C. Miller, (1924, December). The Stokes-Einstein's law for diffusion in solution. In *Proc. R. Soc. Lond.* Vol. 106, No. 740, pp. 724-749). The Royal Society
- [36] J. Hirschfelder, R. B. Bird, and C. F. Curtiss, C. F. (1964). *Molecular theory of gases and liquids*.

Error Correction Algorithm for SRAM Based FPGA

A. T. Salawudeen¹, E. O. Haruna^{2*}, H. Salawu³, S. M. Yusuf¹ and S. Muhammad¹

¹Department of Computer Engineering, Ahmadu Bello University, Zaria

²Centre for Satellite Tech. Devt, National Space Research and Development Agency Abuja, Nigeria.

³Physics Department, Federal University, Lokoja.

⁴Department of Communication Engineering, Ahmadu Bello University, Zaria

*ocholiharuna@gmail.com

Abstract— This paper presents an improved Frame Level Redundancy Scrubbing (FLR) algorithm that uses Cyclic Redundancy Check (CRC) as an error detection technique for configuration memory scrubbing, is developed as a solution to mitigate Single Event Upset (SEU) through upset detection and correction. Fault injection was performed on FPGA configuration memory frames on a different number of modules to emulate SEU. The improved FLR algorithm was implemented and system level simulation was carried out using MATLAB. The performance of the improved FLR algorithm was compared with that of the existing FLR algorithm using error correction time and energy consumption as metrics. The results of this work showed that the improved FLR algorithm produced 31.6% improvement in error correction time and 61.1% improvement in energy consumption over the existing FLR algorithm.

Keyword—FPGA, SRAM, Scrubbing, FLR, SEU, configuration memory, a logic bit(s).

INTRODUCTION

SRAM FPGAs are complementary metal oxide semiconductor (CMOS) devices with a special characteristic of reconfigurability making them desirable for use in systems with evolving technology [1]. The use of FPGAs has been shown to provide high computational density and efficiency for many computing applications by allowing circuits to be customized to any application of interest. They are attractive to critical applications due to their high performance, power consumption, and reconfiguration capability [2], and can be re-configured in the field, design updates can be performed while the device is still operational. Compared to application specific integrated circuits (ASICs), whose functions cannot be altered after fabrication, SRAM-based FPGAs have the advantage of being reprogrammed and providing a lower cost per device in small quantities, therefore, there is great interest in exploiting these benefits in space and other radiation environments [3]. Mapping refers to the configuration of the FPGA device [4]. In SRAM based FPGAs, the mapped circuit is totally controlled by the configuration memory which is composed of SRAM cells [5]. A modern generation FPGA have tens of thousands to millions of system gates, with hundreds of millions of configurations bits, dominating the SRAM cells in the device [6].

While SRAM-based FPGAs offer several advantages for critical based operations, they are sensitive to SEUs. Thus, when a fault changes the state of an SRAM cell, this event is referred as SEU [7]. In other words, SRAM-based FPGAs are more prone to soft errors since a radiation strike in a configuration memory has a permanent effect on the functionality of the mapped design [8]. The SRAM-based FPGAs are especially sensitive to SEUs within the configuration memory of the device. The configuration memory defines the operation of the FPGA resources and upsets in the configuration memory can change the operation of the circuit. To ensure proper operation SRAM-based FPGA circuit designs must mitigate against any configuration memory SEU which could alter the design [9].

The configuration memory of SRAM-based FPGAs is arranged into segments called “configuration frames”, and this represents the largest portion of the memory cells in the device. Some factors that increase the susceptibility to soft errors are the reduction of the transistor size and the lower voltage operations of these SRAM memory cells [1].

Technology scaling leads to an increase in memory density as well as the probability of SEUs and MBUs in adjacent bits due to particle strike. Soft errors (reversible errors) can be generally tolerated in consumer electronics but can have adverse effects in mission-critical applications using SRAM-based FPGA [10]. Soft errors in the configuration memory bits of SRAM based FPGAs have a persistent effect and they remain until the original configuration is rewritten [1]. The presence of high energy protons, heavy ions, and galactic cosmic rays in the space and other radiation environment cause a number of problems for electronics, including FPGAs. This radiation can induce a number of negative effects including upsets in the internal state of the device and can cause several problems in FPGA-based systems. As mentioned earlier, SEUs can corrupt the configuration memory of the device causing the design configured on the device to operate incorrectly [11]. Configuration memory scrubbing is a technique used to correct or mitigate against errors (SEUs) in SRAM-based FPGA after they are detected by other techniques such as CRC. [12]. SEU mitigation is crucial for systems operating in harsh environments with high levels of cosmic radiation. Energetic particles generate charge as they traverse the semi-conducting materials which get deposited inducing voltage transients to the interconnected nodes. [10].

METHODS AND MATERIAL

In this section, the relevant information needed to implement the proposed algorithms are provided.

2.1 Single Event Upset

SEU is a form of Single Event Effects (SEE) which are a

change of logic states or transients in a device induced by energetic radiation particles from the environment in which the device is operated. A single event upset is the change in state of a digital memory element caused by high energy particles such as protons, neutrons, or heavy ions. If the ionizing particle passes from one node to another, and the charge is greater than the device specific critical charge, (critical charge is defined as the minimum amount of charge to flip the data stored in a memory element [18]), this charge transfer can change the voltage level of critical nodes within the configuration memory cell of an FPGA such that the improved voltage level reflects the opposite state of the cell (that is changing a logic "1" to a logic "0" or a logic "0" to a logic "1"). The feedback nature of static latches will preserve this new value and the original value will be lost [3].

A single bit flip can have significant consequences on FPGA functionality and a serious impact on the design itself. For example, a single bit flip in a flip-flop in the Configurable CLB or Lookup Table (LUT) can change a Boolean AND function to a different Boolean function, in other words, any bit-flip in the LUT may cause the logic implemented by it to produce a faulty output as long as it is not corrected. A single bit flip can also change the connections in the FPGA's routing network. The results of an SEU in an FPGA's configuration memory can be unpredictable [19]. Figure 1 demonstrates what may happen to the two-input "AND" gate. When upsets occur in the configuration memory, the first configuration upset is a change in the routing configuration data as shown in Figure 2 that disconnects one input from the "AND" gate. The second configuration upset as depicted in Figure 3 is a change in the look-up table content of the "AND" gate and modifies the operation logic function (it no longer performs the "AND" function rather it now performs an "exclusive OR" function). In both cases, upsets in the configuration memory change the behavior of the circuit so that the circuit no longer performs the function intended by the circuit designer.

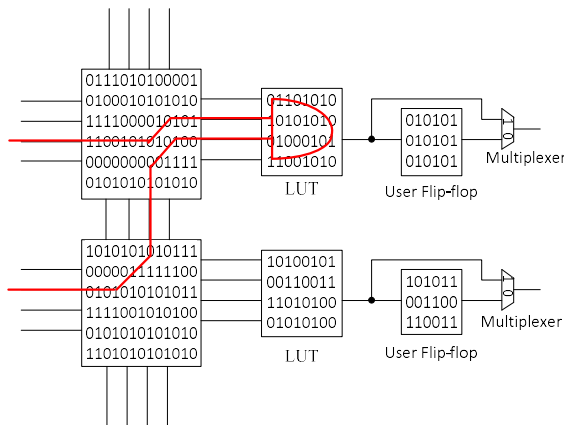

Figure 1: Configuration Memory Used to Specify Logic and Routing [19]

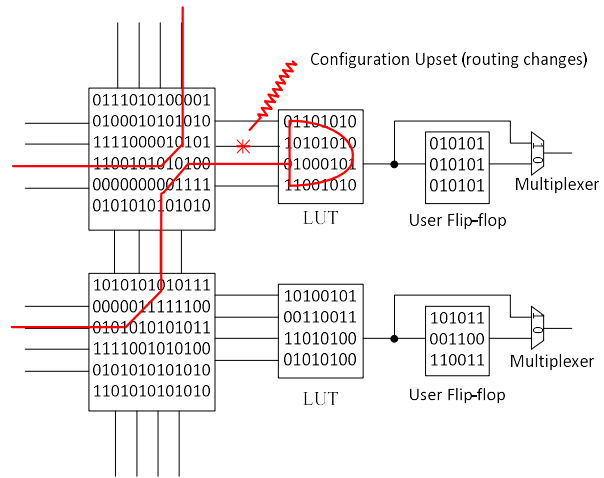

Figure 2: Upset in Routing [19]

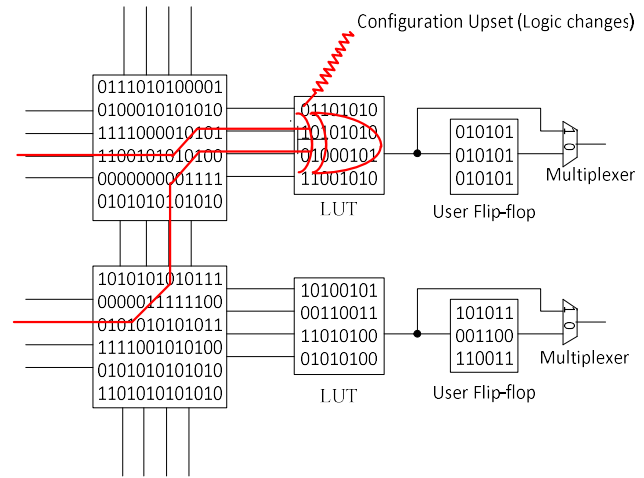

Figure 3: Upset in Logic [19].

2.2 Cyclic Redundancy Check

Besides transferring data as quickly as possible, storage systems have to maintain data integrity, assuring correctness of storage data. Algorithms for data integrity becomes an important component of such system. CRC as an error detection mechanism that maintains data integrity and can be used during readback process on each frame header storing only the check word rather than the entire frame of the configuration data [20, 21].

In the encoding process of an r-bit CRC, after selecting a fixed generator polynomial $G(x)$ having a degree r and $M(x)$ is the message word or data in the configuration memory. Therefore, a multinomial is generated having k-bits of the message word with an appended r-bits redundancy. The following steps are executed (Zhang & Ding, 2011):

- A. Generating a multinomial by multiplying X^{n-k} with $M(x)$ to give

$$X^{n-k}M(x) \tag{1}$$

- B. Dividing $x^{n-k}M(x)$ by $G(x)$ results in a quotient of $Q(x)$ and a remainder of $R(x)$. The degree of $R(x)$ must be smaller than the degree of $G(x)$, that is r .

The result of the division yields:

$$\frac{X^{n-k}M(x)}{G(x)} = Q(x) + \frac{R(x)}{G(x)} \quad (2)$$

where:

$x^{n-k}M(x)$ is the encoded message word

$R(x)$ is the remainder which is the CRC value.

$Q(x)$ is the quotient

Therefore, the encoded message word can be expressed as:

$$X^{n-k}M(x) = G(x)Q(x) + R(x) \quad (3)$$

The data in the storage device is the dividend and the remainder become the result. Every bit in the storage device requires one exclusive-OR (XOR) and one shift operation to the left by the degree of a polynomial minus one bit [22].

2.3 Power Consumption

Configuration memory scrubbing comes with power consumed by the scrubber circuitry. This is because power overhead is driven by the scrub or readback rate. Total power consumption is composed of static and dynamic power. Static power is related to the transistor leakage current and dynamic power is related to the switching activity of transistors and its value depends on the rate of switching. The static power consumption can be considered negligible and the dynamic power is the main contributor to the total power consumption.

The total power consumption (P_T) is the sum of the dynamic power (P_D) and Static Power (P_S). The total power, static and dynamic power is given equation 4, 5 and 6 respectively [23]:

$$P_T = P_D + P_S \quad (4)$$

$$P_S = V_{CC} + I_{CC} \quad (5)$$

Where;

V_{CC} is the voltage level and I_{CC} is the leakage current

$$P_D = \sum_{i=1}^n \beta_i C_i f V_{CC}^2 \quad (6)$$

Where;

n = number of toggling nodes, β_i = switching activity,

C_i = load capacitance of the node, f = clock frequency and

V_{cc} = transistor source voltage

Since all the transistors in an SRAM of an FPGA are turned on independently to the design synthesized into the configurable memory, it is expected that the static power of a design is al-

most constant when compared to the total power consumed of the device. In order to estimate the power overhead of a TMR system implemented in an SRAM-based FPGA, it is assumed that the use of three modules will mainly impact the dynamic power component [23].

3 DEVELOPED SCHEMES

The Methodology adopted in this are as follows:

- A. Replication of the FLR scrubbing algorithm which requires the following steps to be carried out:
 1. Generate configuration memory in the MATLAB environment.
 2. Assign Logic bits to the frame cells representing the mapped designed.
 3. Triplicate the configuration memory to form three modules.
 4. Perform fault injection campaign on the three configuration memory module to randomly flip bits in the frame cells.
 5. Compare logic bits in the same cell position with the same frame address in the three configuration memory module for SEU detection.
 6. Perform bit-level voting for SEU correction.
- B. The following steps describe the improved frame level redundancy internal scrubbing algorithm:
 1. Repeat items 1 to 3 of methodology A.
 2. Compute CRC code to be stored in the configuration memory frame header.
 3. Repeat step 4 of methodology A.
 4. Re-compute cyclic redundancy for error detection.
 5. On detection of SEU, voting is performed on the configuration frame.
- C. Comparison of the results obtained with that of the existing using error correction time and energy consumption as metrics for the purpose of validation.

To the best knowledge of the researchers, there is no known single command capable of generating a random binary array of numbers MATLAB. A command (*rand*) capable of generating a random distribution of numbers with a mean of zero and deviation of 1 do exist. However, since the FPGA configuration memory consists of binary numbers (0 and 1) and based on the numbers of SRAM cells in the FPGA module, this random command was used with a limiting factor to formulate an equation capable of generating the configuration memory containing only random binary logic. Therefore, the expression used to generate the configuration memory is written as:

$$M_n = \phi(\tau) > \eta \quad (7)$$

where,

M_n is the modules array ($n= 1, 2$ and 3), ϕ is a random number generator (*rand*) in the range of 0 and 1, ϕ was implemented as *rand* in the MATLAB script. τ is the FPGA configuration memory module dimension which is an N by D binary matrix.

η is a limiting factor whose values ranges from. A higher value of η will lead to a logic matrix with more 1 and a smaller value of η will lead to a logic matrix with more 0.

3.1 Fault Injection

With the information about the organization of the configuration memory of the FPGA and the specific commands sequence to read and write frames, any bit(s) of the configuration memory can be flip thus emulating the effect of SEU when the FPGA is exposed to radiation environment such as space. For the purpose of this research, the fault injected module is made user dependent.

The existing FLR continuously attempt to perform bit level voting to scrub against SEU on the configuration memory frame irrespective whether there is an upset or not in the configuration memory thereby causing the SRAM cells to be frequently accessed which increases the dynamic power of the device. However, the improved FLR employs CRC as an error detection scheme against SEU, meaning bit level voting is only performed when an upset is detected.

How fast SEUs are mitigated in applications such as space technology is critical because a single bit flip in the sensitive bits in the FPGA configuration memory can cause malfunction of the device or cause the device to produce faulty outputs thereby jeopardizing the satellite mission. Thus, CRC is a fast and effective error detection scheme which detects SEU before they are corrected. The time it takes to correct (scrub) these errors affects the energy consumed in the correction process since energy is a function of time.

4 RESULTS AND DISCUSSIONS

The developed algorithms were implemented in MATLAB and simulation results obtained are presented in this section. Figure 4, shows the error detection time against the number of frames.

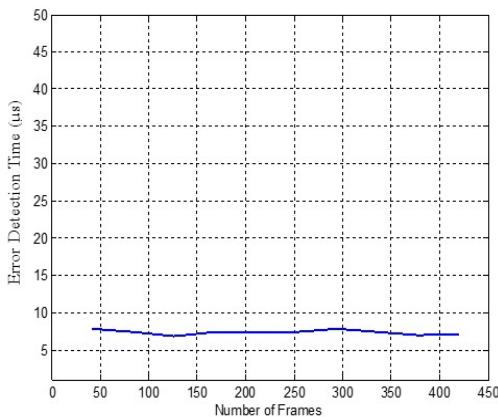

Figure 4: Error Detection Time versus Number of Frames for One Module Fault Injection.

Figure 5 shows the graph of error detection time against a number of the frame in a module, the graph was plotted using MATLAB simulation environment from the simulation parameters and results.

From Figure 4, it was observed that the time to detect an error (SEU) in the improved FLR was within the range of 7.114 and 7.333 microseconds irrespective of the number of frames in a module. As the number of frames increases from 13, 26, 39, 52, and 65 continuously, so also the number of cells in a frame increases from 42, 84, 126, 168, 210 continuously,

and the time to detect error is within the range 7.114 and 7.333 microseconds for a module. This is because CRC is executed concurrently on the module frames and a 16-bit CRC executed can sufficiently detect an error in a frame of Virtex-5 FPGA. Therefore, irrespective of the number of frames the detection time is approximately constant.

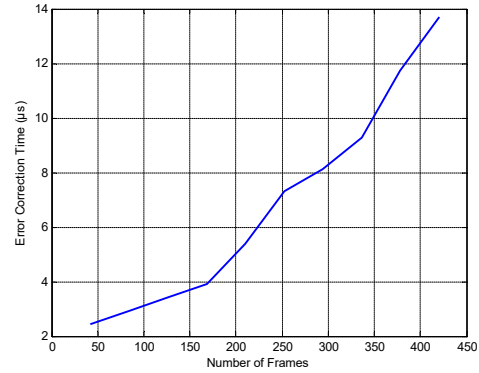

Figure 5: Error Correction time versus Number of Frames for One Module Fault Injection.

From Figure 5, it can be seen that when the number of cells in a frame and number of frames in a module increases, the time is taken to correct error also increases. This indicates that the time it will take to scrub a module is dependent on the number of injected fault and the size location of the fault injection. Because as the location of the fault injected increases, the time to scrub that area size also increases. As it was observed, for a fault injection matrix size of 12,6 24,12 36,18 48,24 60,30 continuously, the error correction time from simulated result was 2.444, 2.933, 3.422, 3.911, 5.377 microseconds respectively.

Figure 6, shows the bar chart for the energy consumed versus a number of frames in a module which was generated using MATLAB simulation environment.

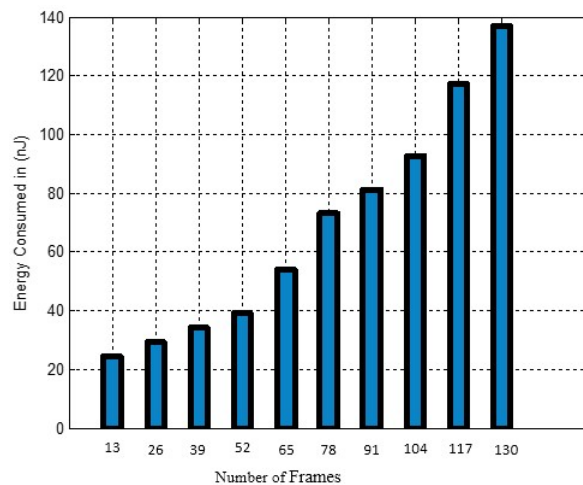

Figure 6: Energy Consumption versus a number of frames for One Module Fault Injection.

Figure 6 is the plot of energy consumed against a number of frames in one module with fault injection. It can be

seen from Figure 6 that as the time to scrub increases with increase in the number of frames as well as an increase in the number of error in one module. Likewise, the energy required to scrub the modules increases as the number of frames and injected fault also increases. This indicates that energy is a function of time at constant power. Therefore, the values obtained for energy to scrub frames is the product of the error correction time with operating power of the FPGA, where the power is the product of the FPGA operating voltage and current. It was observed from the plot that as the number of frames in a module increase from 13, 26, 39, the number of faults injected also increases as the energy required to scrub also increases from 24.44, 29.33, 34.22 Nano joules respectively.

However, in order to depict real-life scenario, SEU can also occur in any two modules (module 1 and 2, module 1 and 3, module 2 and 3) or in all the three modules (module 1, 2 and 3). Therefore, in this work the FPGA keeps in memory the original configuration of the test module for scenario where the assumption for a good bit-level voting those not hold (that is error will not occur in two or all the modules in the same frame address and at exactly the same cell position in the same scrub cycle), although this scenario is very unlikely to occur considering the enormous configuration logic bit in the FPGA and the stochastic nature of SEU.

Generally, it can be concluded that when the fault was injected in only two modules and in three modules for error detection time, error correction time and energy consumption against varying number of frames in a module, the same trend was observed as when a fault is injected in only one module. However, the magnitude of error correction time and energy consumption increases as the number of the module with fault increases from two to three. This is because the total number of injected fault in the FPGA configuration memory increases.

Figure 7 shows the comparison of Error Correction time versus Number of frames in a Module for One Module Fault Injection between Improved FLR and FLR.

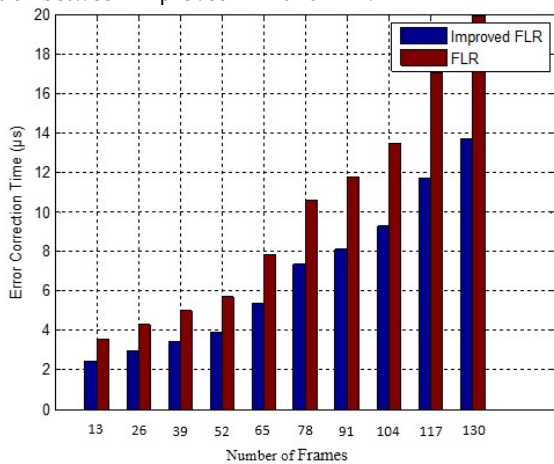

Figure 7: Comparison of Error Correction time versus Number of frames

In Figure 7, the bar chart shows the error correction time for varying module size with 13, 26, 39, 52, 65, 78, 91, 104, 117 and 130 number of frames. The bars show the comparison between the Improved FLR and the existing FLR. It was ob-

served that when the fault was injected on a module with varying number of frames there was a reduction in the time for the Improved FLR scrubbing algorithm to correct the errors as compared to the FLR scrubbing algorithm. For the same number of injected fault, the Improved FLR scrubbing algorithm took 3.422 microseconds to correct the error for a module size with 39 frames (which is the module configuration used by the author in [2]) while the FLR scrubbing algorithm took 5 microseconds. The percentage improvement between Improved FLR and FLR is calculated to be 31.6% using the equation below.

$$\%improvement = \frac{FLR - improved\ FLR}{FLR} \times 100$$

The energy consumption comparison between FLR and Improved FLR is shown in Figure 8

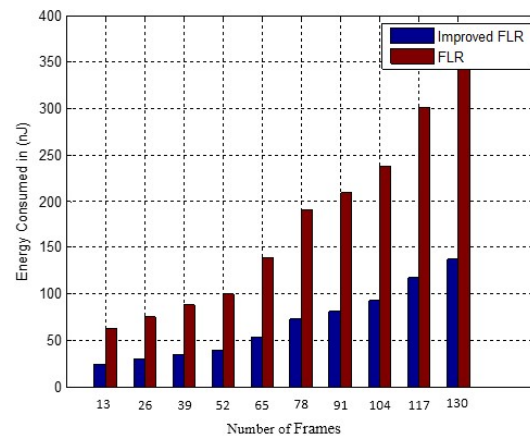

Figure 8: Comparison of Energy Consumption versus Number of frames in a Module for One Module Fault Injection between Improved FLR and FLR.

Figure 8 shows the result of the comparison in terms of energy consumption between Improved FLR and FLR scrubbing algorithm. It is observed that for a module size of 39 frames there was a reduction in the energy consumed to scrub the module when Improved FLR scrubbing algorithm was used as compared to the FLR. The percentage improvement between Improved FLR and FLR is calculated to be 61.1% using equation (8). Significant improvement was also achieved when another module size was examined as it can be clearly seen in Figure 8.

CONCLUSIONS

Frame Level Redundancy is an algorithm developed to scrub the configuration memory of SRAM-based FPGA against SEU when they are deployed in radiation environment with high energy particles such as neutron with energy in the range of Giga electron volts whereby radiation strike flips the logic state in the configuration memory causing a malfunction of the device. How fast this problem is resolved is critical as the process also impacts on the energy consumed. In other to mitigate the challenge of SEU, an improved FLR scrubbing algorithm has been developed using Cyclic Redundancy Check as an error detection technique. This was developed on a MATLAB simulation environment. The result obtained shows that when a fault is injected in one configuration memory module with thirty-nine frames, the improved FLR

performed better than the FLR in terms of error correction time against SEU and the energy consumption by 31.6% and 61.1% respectively.

ACKNOWLEDGMENTS

The authors acknowledge the Nigerian Liquefied Natural Gas (NLNG) for providing us access to the mechatronics axis of the NLNG multi-user lab where we carried out our simulation.

- [1.] Jorge, T., Kastensmidt, F., & Ricardo, R. (2015). Analyzing the Effectiveness of a Frame-Level Redundancy Scrubbing Technique for SRAM-based FPGAs. *IEEE Transactions on Nuclear Science*, 62(6), 3080-3087.
- [2.] Tonfat, J., Fenanda, L. K., Paolo, R., & Ricardo, R. (2015). Energy efficient frame-level redundancy scrubbing technique for SRAM-based FPGAs. *IEEE Transactions on Nuclear Science*, 62(6), 3080-3087.
- [3.] Wirthlin, M. (2015). High-Reliability FPGA-Based Systems: Space, High-Energy Physics, and Beyond. *Proceedings of the IEEE*, 103(3), 379-389.
- [4.] Berg, M., Poivey, C., Petrick, D., Espinosa, D., Lesea, A., LaBel, K., . . . Phan, A. (2008). The effectiveness of internal vs. external SEU scrubbing mitigation strategies in a Xilinx FPGA: Design, test, and analysis. 1-8.
- [5.] Reorda, M. S., Sterpone, L., & Violante, M. (2005). Efficient estimation of SEU effects in SRAM-based FPGAs. Paper presented at the 11th IEEE International On-Line Testing Symposium, IOLTS 2005 54-59.
- [6.] Jing, N., Zhou, J., Jiang, J., Chen, X., He, W., & Mao, Z. (2015). *Redundancy based Interconnect Duplication to Mitigate Soft Errors in SRAM-based FPGAs*. Paper presented at the Proceedings of the IEEE/ACM International Conference on Computer-Aided Design, 764-769.
- [7.] Tambara, L. A., Tarrillo, J., Kastensmidt, F. L., & Sterpone, L. (2016). Fault-Tolerant Manager Core for Dynamic Partial Reconfiguration in FPGAs *FPGAs and Parallel Architectures for Aerospace Applications* (pp. 121-133): Springer.
- [8.] Rao, P., Ebrahimi, M., Seyyedi, R., & Tahoori, M. B. (2014). *Protecting SRAM-Using erasure codes*. Paper presented at the IEEE Design Automation Conference (DAC), 2014 51st ACM/EDAC, 1-6.
- [9.] Graham, P. S., Rollins, N., Wirthlin, M. J., & Caffrey, M. P. (2003). Evaluating TMR Techniques in the Presence of Single Event Upsets. 1-7.
- [10.] Eftaxiopoulos, N., Axelos, N., & Pekmestzi, K. (2016). Low latency radiation tolerant self-repair reconfigurable SRAM architecture. *Microelectronics Reliability*, 56, 202-211.
- [11.] Wirthlin, M. J., Keller, A. M., McCloskey, C., Ridd, P., Lee, D., & Draper, J. (2016). *SEU Mitigation and Validation of the LEON3 Soft Processor Using Triple Modular Redundancy for Space Processing*. Paper presented at the Proceedings of the 2016 ACM/SIGDA International Symposium on Field-Programmable Gate Arrays, 205-214.
- [12.] Sanchez, C. A., Entrena, L., & Garcia-Valderas, M. (2015). *Partial TMR in FPGAs Using Approximate Logic Circuits*. Paper presented at the 2015 15th European Conference on Radiation and Its Effects on Components and Systems (RADECS), Spain, 1-4.
- [13.] Jonathan, J., Howes, W., Wirthlin, M., McMurtrey, D. L., Caffrey, M., Graham, P., & Morgan, K. (2008). *Using duplication with compare for on-line error detection in FPGA-based designs*. Paper presented at the Aerospace Conference, 2008 IEEE 1-11.
- [14.] Lanuzza, M., Zicari, P., Frustaci, F., Perri, S., & Corsonello, P. (2010). Exploiting self-reconfiguration capability to improve SRAM-based FPGA robustness in space and avionics applications. *ACM Transactions on Reconfigurable Technology and Systems (TRETs)*, 4(1), 1-22.
- [15.] Nazar, G. L., Santos, L. P., & Carro, L. (2013). *Accelerated FPGA repair through shifted scrubbing*. Paper presented at the 2013 23rd International Conference on Field Programmable Logic and Applications (FPL), 1-6.
- [16.] Wang, P., Jiang, C., Li, Z., Xue, Q., & Tian, Y. (2014). SEU Mitigation for SRAM Based on Dual Redundancy Check Method. *International Journal of Hybrid Information Technology*, 7(5), 191-200.
- [17.] Wirthlin, M., & Harding, A. (2016). Hybrid Configuration Scrubbing for Xilinx 7-Series FPGAs. *FPGAs and Parallel Architectures for Aerospace Applications* (pp. 91-101): Springer.
- [18.] Jacobs, A., Cieslewski, G., George, A. D., Gordon-Ross, A., & Lam, H. (2012). Reconfigurable fault tolerance: A comprehensive framework for reliable and adaptive FPGA-based space computing. *ACM Transactions on Reconfigurable Technology and Systems (TRETs)*, 5(4), 1-30.
- [19.] Harward, N. A., Gardiner, M. R., Hsiao, L. W., & Wirthlin, M. J. (2016). A fault injection system for measuring soft processor design sensitivity on Virtex-5 FPGAs *FPGAs and Parallel Architectures for Aerospace Applications* (pp. 61-74): Springer.
- [20.] Akagic, A., & Amano, H. (2012). *A study of adaptable co-processors for cyclic redundancy check on an FPGA*. Paper presented at the 2012 International Conference on Field-Programmable Technology (FPT), 119-124.
- [21.] Battezzati, N., Sterpone, L., & Violante, M. (2011). *Reconfigurable Field Programmable Gate Arrays for Mission-Critical Applications*. New York: Springer.
- [22.] Akagić, A., & Amano, H. (2011). High speed CRC with 64-bit generator polynomial on an FPGA. *ACM SIGARCH Computer Architecture News*, 39(4), 72-77.
- [23.] Tarrillo, J., & Kastensmidt, F. L. (2016). Power Analysis in nMR Systems in SRAM-Based FPGAs. *FPGAs and Parallel Architectures for Aerospace Applications*, 103-119.

Optimized Forward Consecutive Mean Excision Algorithm for Adaptive Threshold Estimation in the Energy Detector

H. Abdullahi¹, A. J. Onumanyi¹, S. Zubair¹, H. Bello Salau¹, H. Ohize², S. S. Oyewobi¹

¹Dept. of Telecommunication Engineering, Federal University of Technology, Minna, Niger State, Nigeria

²Dept. of Electrical & Electronics Engineering, Federal University of Technology, Minna, Niger State, Nigeria

*mabdullahihassan@yahoo.com

Abstract – In this paper, we provide a new model for optimizing the parameters of the Forward Consecutive Mean Excision (FCME) algorithm for autonomous threshold estimation in Cognitive Radio (CR). Our new model ensures that the FCME algorithm is made capable of autonomously adjusting its parameter values based on the Cuckoo Search Optimization (CSO) algorithm. The between-class variance function of the Otsu's algorithm was used as the objective function in the CSO algorithm towards ensuring optimal FCME parameter values. The new optimized FCME algorithm was tested using both simulated and real datasets. The comparative results obtained between the optimized and non-optimized FCME algorithm showed better threshold values been estimated via the optimized than the unoptimized algorithms leading to improved detection and false alarm probabilities.

1 INTRODUCTION

Cognitive Radios (CRs) are intelligent wireless communication devices capable of acquiring information about their surrounding Radio Frequency (RF) environment so as to dynamically adjust their radio operating parameters to increase communication reliability [1]-[3]. CRs become aware of their spectral environment based on some form of spectrum identification/awareness process, which is an important task in the CR cycle. This process was emphasized in the first cognitive radio wireless regional area network policy under the IEEE 802.22 draft standard, which specifically proposes spectrum sensing (SS) as the main approach for spectrum identification in CR. Spectrum Sensing (SS) detects the unused frequency spectrum by processing the received signal to decide on the presence or absence of primary user (PU) signals in a certain frequency band.

SS techniques are examined based on the sensing performance of the CR using factors such as the sensing reliability, sensing time and detection probability. Considering these factors, the energy detector (ED) is generally the most popular method for SS in CR because it is simple to develop, quickest to sense, and independent of any prior knowledge of the PU signal waveform [4]-[5]. The ED depends on a threshold value to make decision about the presence/absence of PU signals in a given channel [6]. This threshold system is required to adapt to the changing channel conditions, thus warranting the need for the development of adaptive threshold techniques (ATT). In this regard, the Forward Consecutive Mean Excision (FCME) algorithm stands out as one of the most effective ATTs for threshold estimation in the ED [7] - [11]. It is most useful when the noise statistics is unknown, and essential for setting the threshold value. The effectiveness of the FCME algorithm depends on the choice of its parameter values. These parameters are the Initial clean sample set (Q) and the threshold factor (T_{CME}), which both play an important role in estimating the detection threshold [8].

Most previous works on the FCME algorithm adopted a manual tuning method (trial and error approach) for setting the algorithm's parameter values, often leading to the

poor performance of the algorithm. Furthermore, the parameter values obtained are local values that are specific only to the signal set under consideration. Consequently, these values cannot be considered to be global values, and they are often required to change per varying datasets [11]. This has been mentioned severally in works of Letomakiet alin [7],[8]. They noted that owing to the often local parameter values of the FCME algorithm, it may be necessary to obtain global parameter values and to develop automatic methods for estimating the parameter values of the algorithm for better performance.

Thus, in our work, we considered the development of an approach for optimizing the parameter values of the FCME algorithm towards automating and improving its SS performance in CR. This ensures that the FCME algorithm becomes capable of self-adjusting its parameter values based on the particular input data under consideration. Our work involved the use of the Cuckoo Search Optimization (CSO) algorithm for computing the optimal parameter values of the FCME algorithm. It does so without prior knowledge of the spectral condition under consideration. We show in the result section that this enhancement provides more accurate threshold values leading to less false alarm rates and higher detection performance than the unoptimized FCME.

The rest of the paper is organized as follows: Section 2 provides the description of the system model, Section 3 provides the methodology used to achieve the work, In Section 4, results obtained are discussed, while Conclusion is provided in Section 5.

2 THE SYSTEM MODEL

The spectrum sensing technique (SS) used in this work was based on the Energy Detector (ED) model. It consists of eight 8 basic blocks (see Fig 1) made up of the antenna through which the signal is received, a band pass filter and a possible down converter unit. The sensed signal proceeds to the digitizer unit from the filter unit, where analogue to digital conversion (ADC) takes place. It is then passed to the Fast Fourier Transform (FFT) processor where the signal energy is computed. Thereafter, these

values are squared and averaged by an averaging function. Then, the output is passed to the threshold estimator to determine the status of the channel.

At the output of the ED, a test statistic i.e. the measured signal energy, is subjected to a threshold value, γ , to determine if the channel is vacant, H_0 , or occupied, H_1 . The H_0 hypothesis defines a noise only spectrum, while the H_1 hypothesis indicates the signal plus noise condition. Statistically, these hypotheses are defined as

$$H_0 : y(n) = w(n), n = 1, 2, \dots, V \quad (1)$$

$H_1 : y(n) = x(n) + w(n), n = 1, 2, \dots, V$ (2) where n is the time sample index, V is the total number of measured samples, $x(n)$ is the transmitted signal, $w(n)$ is the Additive White Gaussian Noise (AWGN) and $y(n)$ is the received signal sample. Essentially, the entire detection process is expected to determine either H_0 or H_1 , which strongly depends on the choice of the threshold, γ . Thus, the performance of the ED is determined by the probability of detection, PD and the false alarm PFA, giving by

$$P_D = Pr(Y(k) > \gamma | H_1), k = 1, 2, \dots, V \quad (3)$$

$$P_{FA} = Pr(Y(k) > \gamma | H_0), k = 1, 2, \dots, V \quad (4)$$

To analyze the performance of the estimated threshold after the optimization process, the values of P_D and P_{FA} were computed according to Fawcett [12]. Following Fawcett's method, different ground truths were generated and this came about by visually identifying the different portions in the displayed spectrum that corresponds to the actual signal, and that which corresponds to the noise. The signal points were labeled as true positives, while the noise sam-

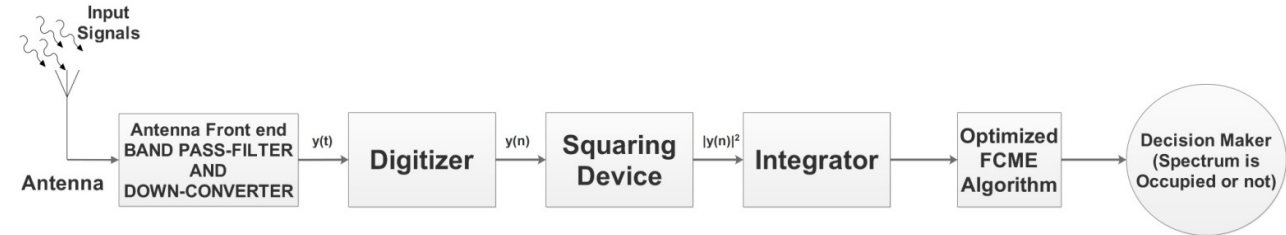

Fig. 1. The Detection System under Consideration

ples were labeled as true negatives. For the real signals, we know the frequencies currently occupied by the licensed user in our local environment. Thus, we labeled the truly noise samples as 0, and the truly signal samples as 1. Furthermore, we used the maximum value of the noise samples to be the true threshold. Then, any sample above this threshold value is truly a signal sample, and below the threshold corresponds to the true noise sample. Using this approach, we can say that the ground truth was developed from the true dynamic range of the sample set. Then by relying on the knowledge of the confusion matrix in [12], we computed the probability of detection, P_D , using

$$P_D = \frac{TP}{P}, \quad (5)$$

Where TP is the number of truly detected signal samples if

$Y(k) > \gamma | H_1$, and P is the total number of actual true signal samples. The probability of false alarm was computed using

$$P_{FA} = \frac{FP}{N}, \quad (6)$$

Where FP denotes the falsely detected signal samples if $Y(k) > \gamma | H_0$, and N is the total number of noise samples.

3 DESCRIPTION OF THE ALGORITHMS

A. The FCME Algorithm

The FCME algorithm is computationally simple and effective. It calculates the threshold iteratively based on the noise properties. The algorithm will be discussed according to [10] for estimating a threshold value.

Initial Preparation: When the noise is assumed to be zero mean, independent, and identically distributed Gaussian noise, i.e., samples then the samples follow a Gaussian distribution, and the FCME algorithm calculates the threshold parameter based on [10]

$$TCME = -\ln(PFA, DES) \quad (7)$$

where $P_{FA, DES}$ is the desired clean sample rejection rate (the target false alarm rate) and N is signal sample length [10]. Energy samples are calculated thereafter. Samples are then rearranged in an ascending order according to their energies. Then, $m = 10\%$ of smallest samples are selected to form the initial set Q (called also as a "clean set").

Algorithm: The FCME threshold is calculated based on

[10]

$$Th = T_{CME} * Q \quad (8)$$

Where Q denotes the mean of m . Samples below the threshold are added to the set Q and new mean and threshold are calculated. This is repeated until there are no more new samples below the threshold. Usually, it takes 3-4 iterations to get the final threshold. In the end, the samples above the threshold are assumed to be signal samples, while samples below the threshold are assumed to be noise samples.

B. Cuckoo Search Optimization Algorithm

The optimization algorithm used to optimize the FCME's parameter values is the Cuckoo Search Optimization (CSO)

algorithm. The advantage of this algorithm lies in its simplicity, ease of implementation, and use of few parameters [13]. Essentially, the CSO concept can be described as follows: each egg in a nest represents a solution; a cuckoo egg represents a new solution. The aim is to use the new and potentially better solutions (cuckoos) to replace not-so-good solutions in the nests. In our adoption of the CSO algorithm, we consider the case for only a single egg, as we desire to determine only a single solution.

C. Proposed FCME-CSO Scheme

This is a combined scheme that seeks to show how the parameter values are optimized before estimating the detection threshold.

Algorithm: Unlike in the FCME algorithm where a single parameter value is estimated according to [10], in our combined FCME-CSO scheme, the CSO algorithm initializes the random parameter values, which are fed to the FCME algorithm. The initial threshold values are then estimated by the FCME algorithm. The initial threshold values are then evaluated by the CSO algorithm using the designed objective function (OF) given in eqn 9. The final optimal FCME parameters are estimated after several iterations by the CSO algorithm. Furthermore, these parameter values are fed into the FCME algorithm to estimate the final detection threshold.

$$\alpha(\gamma) = P_S(\gamma) \times P_N(\gamma) \times [\mu_S(\gamma) - \mu_N(\gamma)]^2 \quad (9)$$

where, $P_S(\gamma)$ is the probability of a signal sample, $P_N(\gamma)$ is the probability of a noise sample, $\mu_S(\gamma)$ is the mean of the signal samples, and $\mu_N(\gamma)$ is the mean of the noise samples. The objective function of eqn 9 enables the FCME and CSO algorithms to estimate the best possible threshold value for the current dataset under consideration. The between-class variance function used according to Otsu in [14] was adopted. It uses linear discriminate analysis to segment an image into two or more classes by selecting a threshold automatically from a grey level histogram. The use of Otsu's model in optimizing the FCME algorithm marks a novel application in our work.

4 RESULTS AND DISCUSSION

In this section, we present the evaluation results for both the FCME and FCME-CSO algorithms. Both simulated and real data sets were used to evaluate both algorithms. The default parameter values used for the FCME algorithm were trained and tested using simulated noise samples under different noise uncertainties levels. This was done to obtain the best possible default parameter values that ensures the threshold value lies above the noise level. It is shown in Fig.2 that the T_{CME} value of 2.3 and Q value of 10% gave the best threshold value above the noise level with a low false alarm rate.

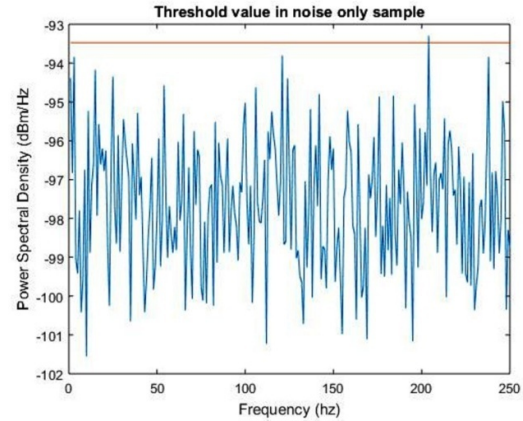

Fig. 2. The Detection System under Consideration

The FCME-CSO parameters were trained by varying the parameter values while keeping other parameters constant. This was done to determine the values that ensures maximum detection probability and lowest false alarm probability with the least computation time in each case. After training both algorithms, the following parameters were set: n (the population size or number of nests) was set at 5, P_a (probability of abandoning a nest) was set at 0.25, number of iteration was 100 and number of simulations was conducted only once.

Performance of the unoptimized FCME and optimized FCME-CSO Algorithms

1) *Under Simulated Datasets.:* The performance of the unoptimized FCME and optimized FCME-CSO algorithm were evaluated using different simulated datasets. Orthogonal Frequency Division Multiplexing (OFDM) signals and FM signals were simulated based on the method of Nee & Prasad [15]. The simulated signals were corrupted using AWGN based on eqn.2, while the signal strength was varied relative to the fixed noise level. The SNR was reduced from a high SNR level (SNR = 10dB), to a low SNR level of 1dB. For the high SNR condition (SNR = 10 dB) down until 5dB SNR for the OFDM signals, the result showed that both algorithms, FCME and FCME-CSO performed well (all typically producing above 90% detection rate, and 0% false alarm rate). However, at a SNR of 3dB and 1dB, FCME-CSO produced a 100% detection with a false alarm rate of 14.35% and 43.67% respectively. While FCME produced $P_D = 8.8\%$, $P_{FA} = 0\%$, and $P_D =$

20%, $P_{FA} = 0\%$. It showed that better results were obtained using the optimized FCME-CSO model than the unoptimized FCME algorithm. Numerical details of the results are shown in Table 2. While for the simulated FM signal, the results showed that the unoptimized FCME algorithm performed better in terms of the $P_{FA} = 0\%$ for all SNR conditions. This confirms that the best parameter values ($T_{CME} = 2.3$, $Q = 0.1$) were used in training the algorithm considering the simulated AWGN samples. The higher SNR condition of 10dB, 5dB, 3dB and 1dB produced $\{(P_D = 66.67\%, P_{FA} = 0\%), (P_D = 100\%, P_{FA} = 42.86\%), (P_D = 100\%, P_{FA} = 44.08\%), (P_D = 100\%, P_{FA} = 45.78\%)\}$ respectively. The nu-

merical details obtained are provided in Table 3.

2) *Under Real Datasets.*:Both algorithms were tested using real input datasets. The performances of both algorithms (FCME and FCME-CSO) were evaluated using the real OFDM signals and real FM band (89-95MHz). The results showed that both algorithms performed well for the real OFDM signal set producing above 90% detection rate and less than 10% false alarm rate. However, for the real FM signal set, the results showed that the FCME-CSO produced ($P_D = 80\%, P_{FA} = 0\%$) and FCME produced ($P_D = 82\%, P_{FA} = 47\%$). The numerical details are provided in Table 4. These results showed that optimized FCME-CSO produced a better performance compared to the unoptimized FCME, which has a higher false alarm rate as shown in the Figs. 3a and 3b.

TABLE III
PERFORMANCE ANALYSIS FOR REAL DATASETS

Algorithms	P_D	P_{FA}	$Th(dBm)$
Unoptimized-FCME	80	47	-74.76
Optimized-FCME	82	0	-74.31

5 CONCLUSION

This paper has presented an optimized Forward Consecutive Mean Excision (FCME) algorithm based on the Cuckoo Search Optimization (CSO) algorithm. The CSO algorithm was innovatively incorporated into the FCME algorithm to automatically estimate the FCME algorithm’s parameter values for each unique input dataset. Thus, the fixed and manual tuning approach for determining the FCME’s parameter values has now been fully automated. The new FCME-CSO model was evaluated using both simulated and real datasets. The results obtained shows an improvement in the detection and false alarm probability of the optimized FCME over the unoptimized version. The FCME-CSO model has been shown to perform well in very low SNR levels ($<3\text{ dB}$).

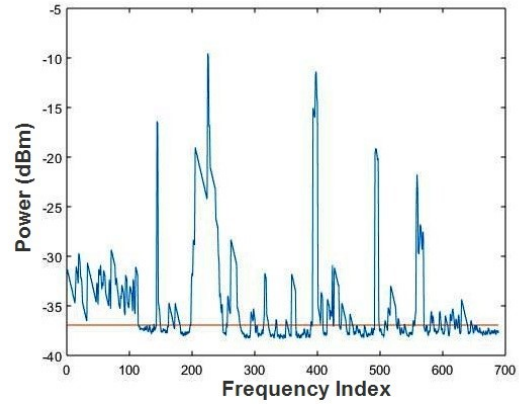

(a) Threshold Using Unoptimized FCME algorithm

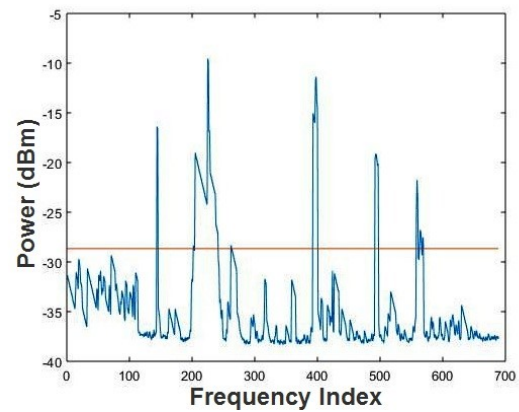

(b) Threshold Using Optimized FCME algorithm

Fig. 3. Threshold Estimation using both Unoptimized and Optimized FCME algorithm

TABLE I

PERFORMANCE COMPARISON BETWEEN UNOPTIMIZED FCME AND OPTIMIZED FCME-CSO WITH DIFFERENT NOISE UNCERTAINTY FOR SIMULATED OFDM SIGNALS

Algorithms	SNR = 10dB			SNR = 10dB			SNR = 10dB			SNR = 10dB		
	P_{FA}	P_D	$Th(dBm)$	P_{FA}	P_D	$Th(dBm)$	P_{FA}	P_D	$Th(dBm)$	P_{FA}	P_D	$Th(dBm)$
Optimized-FCME	0	98.08	-96.22	0	96.08	-97.19	14.35	100	-98.67	43.67	100	-99.74
Unoptimized-FCME	0	98.08	-96/93	0	86.3	-96.28	0	8.8	-95.3	0	20	-96.24

TABLE II

PERFORMANCE COMPARISON BETWEEN UNOPTIMIZED FCME AND OPTIMIZED FCME-CSO WITH DIFFERENT NOISE UNCERTAINTY FOR SIMULATED FM SIGNALS

Algorithms	SNR = 10dB			SNR = 10dB			SNR = 10dB			SNR = 10dB		
	P_{FA}	P_D	$Th(dBm)$	P_{FA}	P_D	$Th(dBm)$	P_{FA}	P_D	$Th(dBm)$	P_{FA}	P_D	$Th(dBm)$
Optimized-FCME	0	66.67	-96.06	42.86	100	-99.86	44.08	100	-98.67	45.78	100	-99.97
Unoptimized-FCME	0	66.67	-96.58	0	60	-96.8	0	40	-96.57	0	10	-96.78

REFERENCES

[1] Tevfik Yucek and Huseyin Arslan, "A survey of spectrum sensing algorithms for cognitive radio applications," *IEEE Communications surveys & tutorials*, vol. 11, no. 1, First Quarter 2009.

[2] S. Haykin, "Cognitive Radio: Brain-Empowered Wireless Communications," *IEEE Journal On Selected Areas in Communications*, vol. 23, no. 2, pp. 201-220, 2005.

[3] S. Haykin, "Cognitive radio: Brain-empowered wireless communications," *IEEE Journal in Selected Areas in Comm.*, vol. 23, no. 2, Feb. 2005, pp. 201-220.

[4] Gorcin A, Qaraqe KA, Celebi H, Arslan H. An adaptive threshold method for spectrum sensing in multi-channel cognitive radio networks. 2010 IEEE 17th International Conference on Telecommunications (ICT). IEEE; 2010. p. 425-9.

[5] M. Nekovee, "Impact of cognitive radio on future management of spectrum," 3rd International Conference on Cognitive Radio-Oriented Wireless Networks and Communications (CrownCom), pp. 1-6, May. 2008.

[6] Benjamin SM. The logic of scarcity: idle spectrum as a first amendment violation. *Duke Law J* 2002;1-111.

[7] Lehtomaki J., Juntti M. & Harri S., "CFAR strategies for channelized radiometer," in 2015, *IEEE signal processing letters* vol.12, no. 1, pp. 13-16 January 2015

[8] Lehtomaki J., Juntti M., Harri S. & Johanna V., "Spectrum sensing with forward methods," in 2008, *CWC* (2008) pp.1-7 Oulu. Finland

[9] Lehtomaki JJ, Vuotoniemi R, Umebayashi K. On the measurement of duty cycle and channel occupancy rate. *IEEE J Sel Areas. Commun* 2013;31 (11):2555-65.

[10] Johanna V. & Risto V., "False alarm rate analysis of the FCME algorithm in cognitive radio application," in 2015, *AICT* 2015, 11th edition pp. 102-106, oulu Finland

[11] H. Saamisaari and P. Henttu, "Impulse detection and rejection methods for radio systems," in *IEEE Military Communications Conference, 2003. (MILCOM 2003)*, vol. 2, pp. 1126-1131, IEEE, 2003.

[12] Fawcett T. An introduction to roc analysis. *Pattern Recognit Lett* 2006;27 (8):861-74.

[13] Zheng H. & Zhou Y., "A novel cuckoo search optimization algorithm base on gauss distribution," *Journal of computational information system* 8:10 (2012) 4193-4200

[14] Otsu N. A threshold selection method from gray-level histograms. *Automatica* 1975;11(285-296):23-7.

[15] Nee RV, Prasad R. *OFDM for wireless multimedia communications*. Artech House Inc; 2000.

Real Time Universal Scalable Wireless Sensor Network for Environmental Monitoring Application

Idakwo M.A^{1*}, Umoh I.J^{2,1}, Tekanyi A.M.S^{3,2}, Adedokun E.A^{4,1}, Muazu M.B^{5,1}

¹Computer and Control Engineering Department, Ahmadu Bello University Zaria, Nigeria

²Electrical and Communication Engineering Department, Ahmadu Bello University Zaria, Nigeria

*modabutu@gmail.com

Abstract— *There are several wireless sensor network use for environmental monitoring applications. However, most wireless sensor network designed for real time environmental monitoring application are application specific and static in nature. Hence, the need for reprogramming of base station for every change in sensor type or the introduction of a new sensor node into the network. More so, since these sensors nodes are deploy by end users in a random region of interest, it is necessary to develop a new plug and play mechanisms with more software modules and more user-friendly interface that is scalable to ease larger area deployment, installation and maintenance. Hence, this paper developed a base station with an auto detection and configuration system for detecting new sensor node, faulty nodes, and update user in real time. The developed system is implemented on a mesh topology network and was calibrated using standard Davis vantage pro2 weather station in Ahmadu Bello University Liquefied Natural Gas Environmental Laboratory and a mean error of 0.12 and root mean square error of 0.14 were obtained.*

Keyword— Auto Detection, Auto Configuration, Base Station, Calibration, Real Time, Sensor Node, Wireless Sensor Network

1. INTRODUCTION

A wireless sensor network (WSN) consist of devices equipped with sensors, radio transceivers, microcontroller that cooperate to form fully connected network of a sensor node [1]. WSN technology has the capability to capture critical high resolution data quickly, process, and transmit for real time monitoring [2].

Most existing WSN real time environmental monitoring systems, are application specific and static in nature [3]. This means that they are programmed to monitor a specific environmental parameter, thereby, requiring reprogramming of the base station for every change in sensor type or introduction of new sensor nodes into the network which made the system to be user defined.

More so, to enable reliable detection of observed phenomena in real-life applications, thousands of nodes are usually installed throughout region of interest [4]. However, the nodes that are at a large distance from the base station will have poor quality connections to the base station [5] and these increases transmission power due to frequent retransmission. Hence, a mesh topology network is most suitable due to it scalability, self-configuration, self-healing and flexibility[13].The mesh topology also provides extension of network coverage without increasing transmission power or receive sensitivity, better reliability via route redundancy, easier network configuration and better device battery life due to fewer retransmissions [9]. For successful application of WSN in environmental monitoring, low cost, easy deployment, and maintenance are substantive but the current software technologies for WSNs lack

the feature of dynamic sensing [6] which makes the system application dependent.

In order to increase effectiveness of WSN, sensor systems must increasingly become easily reconfigurable and adjustable to support system evolution and optimization [6]. Since most WSNs are deployed by end users, it is paramount to design new plug and play mechanisms with more software modules for friendly user interfaces [7] to ease installation and maintenance. These paper introduced an auto detection and configuration module into the WSN. These enables the end user graphical interface to be adaptable to any sensor type and give real time status of the sensor nodes for easy fault detection which might be due to power outage, communication failure, etc.

The contribution of this paper are highlighted as follows:

- The developed system has an auto detection and configuration system for real time detection of new sensor node, new sensor types and faulty sensor nodes on a friendly user interface.
- The developed system is scalable as it is implemented on a mesh network topology which allows sensors node communication beyond the base station range.
- The developed system is calibrated using standard Davis vantage pro2 weather station and a mean error of 0.12 and root mean square error of 0.14 were obtained.

2 WIRELESS SENSOR NETWORK DESIGN

The system developed includes a base station and nine (9) distributed wireless sensor nodes

2.1 The Sensor Node Design

In this research, a mesh topology network was implemented on Arduino and nRF24L01 transceivers which acted as the sensor nodes. A total of nine (9) sensor nodes were designed and used. An Arduino is an open source single-board microcontroller with easy-to use hardware and software components that is widely used due to its flexibility [10]. It uses Atmel Atmega328 microcontroller with a clock speed of 16 MHz. Several sensors can be attached to a single board as it has 14 digital I/O pins and 6 analogue inputs [8]. The nRF24L01 is a 2.4GHz transceiver for low power wireless application with a data rate up to 2Mbps [11] and cover a distance up to 1.5km. The nRF24L01 also has six (6) transmit/receive hardware pipes and can transmit data on one (1) pipe while synchronously listen using the remaining five (5) pipes, this eases the implementation of mesh topology network [12]. The sensor nodes designed is shown in Figure 1.

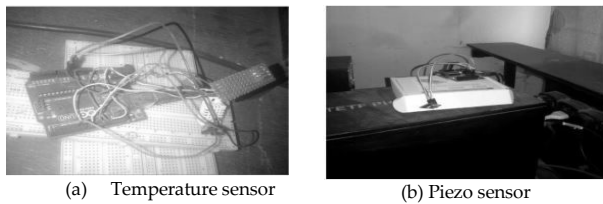

Figure 1: Sensor Nodes Hardware Setup

2.2 The Base Station Design

The base station comprised of nRF24L01 and Raspberry Pi Model B as shown in Figure 2. The Raspberry Pi board uses ARM processor CPU with a clock speed of 700 MHz. It has 512MB RAM, SD Card storage, and 8 GPIO port for expansion and varieties of interfacing peripheral such as HDMI port and USB port [8]. In this design, Raspbian operating systems was used. The Raspberry pi is connected to nRF24L01 transceiver which is configured as the Personal Area Network (PAN) coordinator and provide DHCP services to the sensor nodes.

More so, an Apache HTTP web server is built on the Raspberry pi to run the web server application for Graphical User Display (GUI). The client side web interface was implemented using PHP, CSS, Ajax, JQuery, Flot and HTML. The styling of the web page was done using CSS and HTML, while the interactive user interface and dynamic display was done using JavaScript. PHP, Ajax and jQuery fed the GUI with real time continuous data from the MySQL database without page refreshing. The nRF24L01 data rate is set to 1Mbps to enable compatibility with other radios like nRF2401A, nRF24E1, nRF2402, etc.

The base station node is connected to ABU Electrical and Computer Engineering router with a static public internet protocol address to enable remote monitoring within and outside the school premises as shown in Figure 2. More so, mesh code modules, auto detection and configuration modules were developed in C++ on the base station node. Figure 3 and Figure 4 shows the detailed block diagram and flow chart of the developed system respectively.

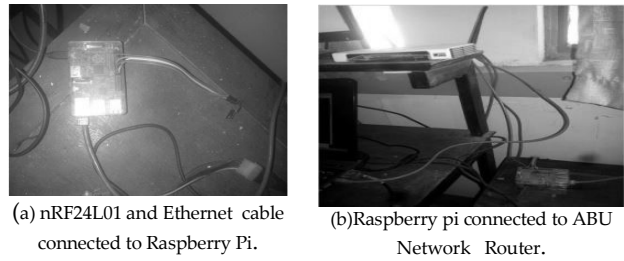

Figure 2: Base Station Hardware Setup

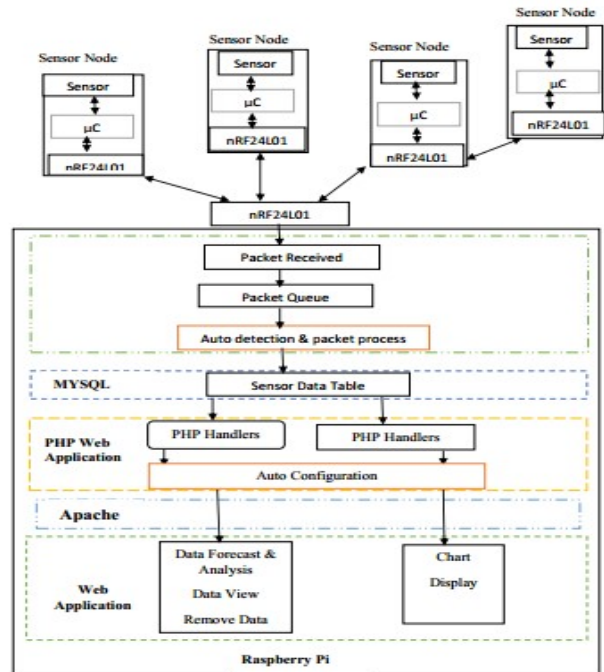

Figure 3: Detailed Block Diagram of the Developed System

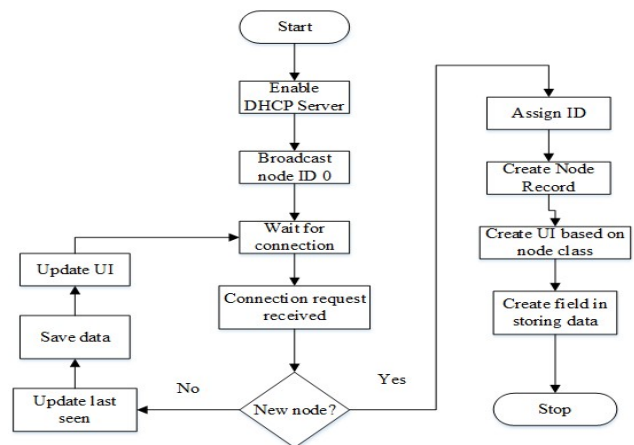

Figure 4: Flow Chart of Auto Detection and Configuration

3 EXPERIMENTAL SETUP AND RESULTS

The experimental setup is carried out in ABU Electrical and Computer Engineering department while the sensor nodes calibration was done in ABU Liquefied Natural Gas Environmental Laboratory.

3.1 Developed System Calibration

In order to measure the accuracy of the developed system with standard device, the developed system node was placed under the same condition with ABU LNG Davis Vantage Pro2 weather station to capture real time temperature data as shown in Figure 5(a). These data were monitored and captured on Tuesday 24th December 2017 from 9:00 am to 12:00 pm at an interval of 10 minutes.



(a) Developed system and Referenced Weather station outdoor unit. (b) Developed system and Referenced Weather station indoor unit.

Figure 5. Developed System and Reference Weather Station Monitoring.

Raw serial data which has not undergone analogue to digital conversion were extracted from Davis Vantage Pro2 using weather link software installed on the PC connected to the base station through a USB cable as shown in Figure 5(b). These data were necessary to determine the accuracy of the developed system as the weather station only display digital value. The captured data graph is shown in Figure 6.

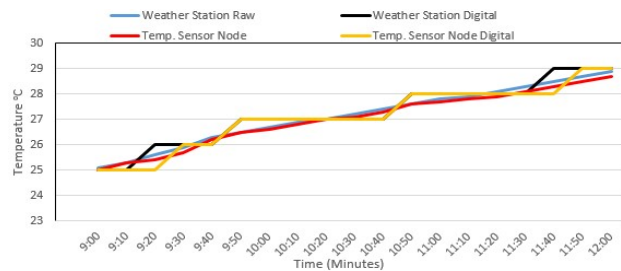

Figure 6. Comparison of Reference and the Developed Sensor Node Temperature Data.

From Figure 6 the digital data readings of the developed system showed a variation from the standard weather station between 9:10 am to 9:30am and also from 11:30 am to 11:50am. The variance in raw data readings is minimal and the difference is due to the elevation of the weather station, protection from direct sunlight, and microclimate. In order to evaluate the performance of the developed system, the calibrated performance result was compared with the calibrated result of Open Source Hardware Weather Station (OSH-WS) [10] which also used the same Davis vantage pro2 weather station as a referenced calibrator. The comparison is as shown in Table 1.

Table 1. Performance Evaluation

System	ME	RMSE
OSH-WS	0.3	0.7
Developed System	0.12	0.14

From Table 1, the performance evaluation shows a 60% improvement over OSH-WS. More so, further comparison was carried out with Zaria temperature data captured from wunderground website on 27th January 2018 between 10:00am to 3:00pm as shown in Figure 7.

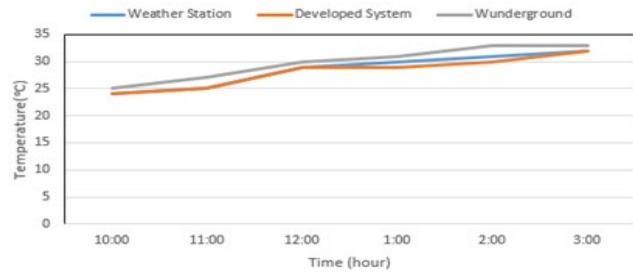

Figure 7: Weather Station, Developed System and Wunderground Temperature Data

From Figure 7, the temperature data obtained from the weather station and the developed system placed under the same conditions are the same with a little deviation between 12:10pm and 2:50pm. This deviation was due to a tree shadow casted on the developed system outdoor unit between the periods, while the deviation of the temperature data from the wunderground system was due to the location differences.

3.2 Auto Detection Test Result

In order to test the base station auto detection and configuration modules, eight wireless sensor nodes were introduced into the network. Four (4) sensor nodes were placed at a distance of 1.4km from the base station. The remaining sensor nodes were placed at a distance of 2.5km which is outside the base station network range and the terminal view is as shown in Figure 8.

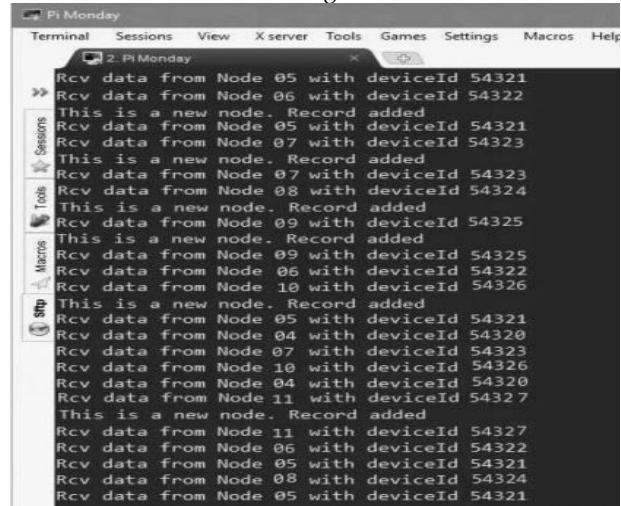
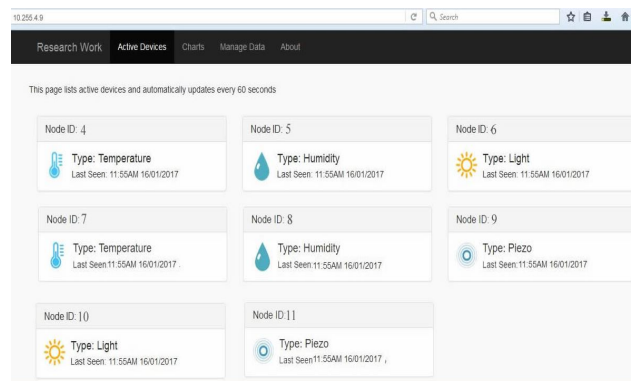

Figure 8. Raspberry pi terminal view of nodes

Figure 8 shows Raspberry pi terminal view of auto detected nodes. Four (4) nodes (4, 5, 6, and 7) were auto detected within the network range. The first time the nodes were introduced into the network the auto detection modules detected and recorded their device ID. The mesh code libraries implemented on the PAN Coordinator route node (7, 8, 9, 10 and 11) through the neighboring node (4, 5, 6, and 7) using shortest path as metric.

3.3 Auto Configuration Test Result

The auto configuration module automatically configures detected sensor nodes on GUI as shown in Figure 9.



(a) GUI of Eight active nodes (4,5,6,7,8,9,10,11)

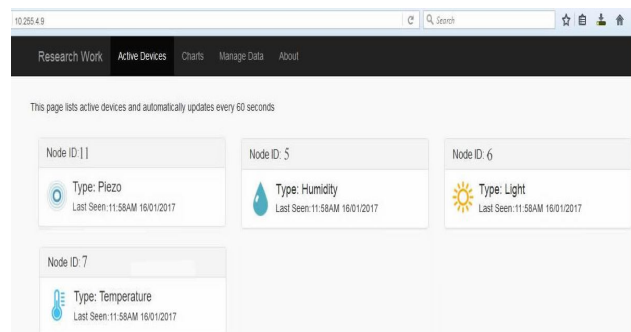

(b) GUI of Four active nodes (11,5,6,7)

Figure 9. Auto configuration of actives sensors nodes

A 60 seconds time slot was assigned to monitor active devices for quick detection of faulty nodes. Once the base station did not receive data from any connected devices and the 60 seconds time slot elapsed, the device is tagged inactive and removed from the UI. This help the users to easily detect failed sensors nodes which might be due to loss of power, connection problem etc. Figure 9(a) shows the GUI of eight (8) active auto detected sensor nodes (4, 5, 6, 7, 8, 9, 10, and 11). In other to test the implemented mesh topology network, two nodes (4, 10) within the base station were removed and after 60 seconds, nodes (8, 9) route to the base station through them were removed automatically as shown in Figure 9(b).

4 CONCLUSION

In this paper, a real time universal scalable wireless sensor network for environmental monitoring application has been presented. The developed system was calibrated using standard David Vantage Pro2 weather station and a mean error of 0.12 and root mean error of 0.14 were obtained. The developed system has an auto detection and configuration modules which uses a 60 seconds time slot for detecting active devices. This help in detecting faulty or failed sensor nodes on the user friendly interface.

REFERENCES

- [1] Asutkar, S.; and Pethe, R. (2015). Hardware Specification for Wireless Sensor Node for Real Time Data Acquisition. *International journal of Engineering Science Invention Research & Development*, 7(1), 2349-6185.
- [2] Ramesh, M.V. (2012). Real-time wireless sensor network for landslide detection. *Sensor Technologies and Applications*, 3(1), 405-409.
- [3] Man, K.L.; Hughes, D.; Guan, S.U.; and Wong, P.W. (2016). Middleware Support for Dynamic Sensing Applications. *Platform Technology and Service (PlatCon), 2016 International Conference*, 1-4.
- [4] Mikhaylov, K.; Petäjajarvi, J.; Mäkeläinen, M.; Paatelma, A.; and Hänninen, T.(2015). Extensible modular wireless sensor and actuator network and IoT platform with Plug & Play module connection. *Proceedings of the 14th International Conference on Information Processing in Sensor Networks*, 386-387.
- [5] Kaur, G., & Garg, R.M. (2012). Energy efficient topologies for wireless sensor networks. *International Journal of Distributed and Parallel Systems*, 3(5), 179.
- [6] Man, K.L.; Hughes, D.; Guan, S.U.; and Wong, P. W. (2016). Middleware Support for Dynamic Sensing Applications. *Platform Technology and Service (PlatCon), 2016 International Conference*, 1-4.
- [7] Oliveira L.M.; and Rodrigues, J.J. (2011).Wireless Sensor Networks: A Survey on Environmental Monitoring," *Journal of Communication*, 6(2), 143-151.
- [8] Idakwo M.A.; Umoh I.J.; and Man-Yahaya S. (2017). Real Time Wireless Sensor Network for Environmental Data Prediction and Monitoring. *International Journal of Scientific & Engineering Research*, 8(1), 2229-5518.
- [9] Raghavan V.; and Shahnasser, H. (2015). Embedded Wireless Sensor Network for Environment Monitoring. *Journal of Advances in Computer Networks*, 3(1)
- [10] Mesas-Carrascosa, F.; Santano, D.V.; Merono, J.; Orden, M.S.; and García-Ferrer, A. (2015). Open source hardware to monitor environmental parameters in precision agriculture. *Biosystems Engineering*, 137, 7383.
- [11] Singh R.; and Singh, S. (2015). Development of a Low Cost Wireless Temperature Monitoring System for Industrial & Research Application. *International Journal of Current Engineering Technology*, 5, 355-361.
- [12] Sonavane, S. S., Patil, B. P., & Kumar, V. (2017). Experimentation for packet loss on MSP430 and nRF24L01 based wireless sensor network. *International Journal of Advanced Networking and Applications*, 8(5), 25.
- [13] Moridi, M. A., Kawamura, Y., Sharifzadeh, M., Chanda, E. K., Wagner, M., & Okawa, H. (2018). Performance analysis of ZigBee network topologies for underground space monitoring and communication systems. *Tunnelling and Underground Space Technology*, 71, 201-209.

Pastoralist Optimization Algorithm (POA): A Novel Nature-Inspired Metaheuristic Optimization Algorithm

Ibrahim M. Abdullahi^{1*}, Muhammed B. Mu'azu², Olayemi M. Olaniyi¹ and James Agajo¹

¹Department of Computer Engineering, Federal University of Technology, Minna, Nigeria

²Department of Computer Engineering, Ahmadu Bello University, Zaria, Nigeria

*amibrahim@futminna.edu.ng

Abstract— This paper proposes the development of a novel optimization algorithm called the Pastoralist Optimization Algorithm (POA) inspired by the pastoralists herding strategies. The strategies are scouting, camp selection, camping, herd splitting and merging. These strategies were modelled mathematically and used to develop the POA. The performance of the algorithm was evaluated by testing the algorithm on 10 unimodal and multimodal test benchmark functions. This is to measure the algorithm exploitative, explorative, convergence speed as well as the ability to escape being trapped in a local optimum solution. Also, a nonparametric statistical test (Wilcoxon rank sum tests) was carried out to ascertain the statistical significance level of the proposed algorithm results. The experimental results obtained show that the algorithm is very competitive and obtain better results in most cases when compared with some similar existing state-of-the-art nature-inspired metaheuristic optimization algorithms. Also, it is statistical proven tht the results are very significant.

Keyword— Algorithms; Benchmark test functions; Nature inspired metaheuristic algorithms; Pastoralist Optimization Algorithm

1 INTRODUCTION

The rapid growth in technology has brought to the fore the need for faster and more accurate solutions to emerging complex real-world problems. As technology advances and our understanding of real-world Optimization problems (OP) (with their sometimes complex, multi-modal, non-linear and dynamic nature) also improves, it then becomes imperative to continue to seek for new solutions to these emerging problems in nature. Despite the successes recorded by most developed state-of-the-art meta-heuristic Optimization Algorithm (OA) inspired by different natural phenomenon to solve wide range of emerging real-world OP [1], no single OA can provide the most appropriate solution to all OP. Hence, developing a new OA that could provide better solution to some OP is still an open research problem in this field [2].

Examples of some successful NI-OA's and their inspirations include; Biogeography-based Optimization [3] inspired by the geographical distribution of biological organisms, Artificial Bee Colony [4] inspired by the foraging behavior of bees. Teaching Learning Based Optimization [5] inspired by classroom teaching and learning, Imperialist Competitive Algorithm [6] inspired by human socio-political evolution process. Others are; Grasshopper Optimization Algorithm [7] inspired by the swarming behaviors of Grasshoppers, Ant Lion Optimizer [8] inspired by the behavior of ant lion and Lion optimization algorithm [9] inspired by special behaviors of lions. This paper proposes the development of a novel NI-OA inspired by pastoralist herding strategies called Pastoralist Optimization Algorithm (POA).

This paper is structured as follows: In Section 1, optimization and review of related works were presented. In section 2, the proposed POA is presented followed by the experimental results and discussion in Section 3 and finally, conclusion and recommendation in Section 4.

2 PASTORALIST OPTIMIZATION ALGORITHM (POA)

In this section, the inspiration behind the proposed POA is discussed. This is followed by mathematical modelling of each pastoral herding strategy and the proposed POA.

2.1 Inspiration

Pastoralism is a socio-economic livestock production system characterized by extensive movement of animals in search of quality pastures and water [10]. Nomadic pastoralism among other forms of pastoralism (transhumance, semi-nomadic and sedentary) is a highly sustainable and flexible system that allows the pastoralists to manage livestock, environment and people efficiently using some highly flexible strategies. These strategies help the nomadic pastoralists to survive the unpredictable and potentially hazardous pastoral life [11]. The strategies adopted by the nomadic pastoralist include the following:

Scouting [12], Camp Selection and Camping [13], Splitting/Herd Dispersal, [14], Merging and Selection of New Camp, [15]. These strategies make nomadic pastoralism a potentially good candidate for the development of an optimization algorithm. In POA, a set of pastoralists were randomly generated to form the initial population of the search space. 25% of pastoralists are selected as scout pastoralists from the initial pastoralist population [12]. The scout pastoralists search for the best location for camping. The camps with a given radius are temporary locations where daily herding to other locations within the search area takes place. The size of the camp also depends on the size of herds and search space. During herding, pastoralist split themselves to minimize risk of getting stuck or better grazing for animals where resources are limited. This is followed by merging where the fitness of each pastoralist is evaluated and the decision for a new camp search is tak-

en.

2.2 Proposed POA

The nomadic pastoralist strategies described under section 2.1 were modeled mathematically as follows:

2.2.1 Initialization

The first step in developing the POA is to generate the population of pastoralist (nP) randomly because POA is a population-based metaheuristic algorithm. In POA, a solution is called a pastoralist which is represented in the search space as:

$$P = [P_1, P_2, P_3, \dots, P_D] \quad (1)$$

Where, P is the pastoralist and D is the dimension or number of variables of the optimization problem. The second step is to select (25%) of the pastoralist as scout pastoralist (S) represented as;

$$S = [S_1, S_2, S_3, \dots, S_D] \quad (2)$$

2.2.2 Scouting

After selecting the number of scout pastoralist, their locations are initialized randomly within the search space using Equation (3) and followed by evaluation of fitness of each scout. The fitness of scout j is evaluated using Equation (4) followed by sorting and selection of best scout until scouting rate is maximum, else, the scouts move into a new location guided by the previous best location using Equation (5).

$$S_j = \text{rand}([L_b, U_b])^D \quad (3)$$

$$F(S_j) = FF(S_j) \quad (4)$$

$$S'_j = (S_{best} - S_j) + \epsilon_j * \eta_j * \zeta \quad (5)$$

Where $\text{rand}([L_b, U_b])^D$ is a D-dimensional random vector between the lower bound and upper bound of the search space and FF is the fitness function, s' is the new location of scout j around the best-found location S_{best} , ϵ_j is the energy of scout j over D-dimension ($\epsilon \in [-1, 1]$), η_j is the step size of scout j ($\eta \in \{0, (0.001 * Ub)\}$) and ζ is the scouting constant. The scout location update was modelled using some attributes (energy and walking gait) of the human movement and energy efficiency model proposed in [16].

After updating the scouts locations, their fitnesses are evaluated again using Equation (4). This is followed by sorting and selection of best scout location until maximum scouting rate (α) is reached. Equation (6) is used to prevent the pastoralist from going outside the search space.

$$S'_j = \begin{cases} \max(S'_j, L_b), & \text{if } S'_j < L_b \\ \min(S'_j, U_b), & \text{if } S'_j > U_b \end{cases} \quad (6)$$

2.2.3 Camp Selection and Camping

Selection of the best location for camping S_{Cbest} is obtained by sorting and selecting the best scout in terms of their fitness after completing the maximum scouting iteration. The kth pastoralist P_k is initialized at camp C (where $C = S_{Cbest}$) using Equation (7).

$$P_k = C \quad (7)$$

2.2.4 Herding

The fitness of the kth pastoralist is evaluated using Equation (8) during herding. This is followed by sorting and selection of the best pastoralist P_{best} .

$$F(P_k) = FF(P_k) \quad (8)$$

2.2.5 Splitting

Each pastoralist split to different locations within the same camp until splitting rate (β) is maximum using Equation (9) which also follows modification of [16].

$$P'_k = P_{best} + (\text{rand}(0, r) * \epsilon_k * \eta_k) \quad (9)$$

Where P'_k is the kth pastoralist new location, P_{best} is the best pastoralist so far, $\text{rand}(0, r)$ is a random between 0 to r, r is the camp radius, ϵ_k is the energy of the kth pastoralist over D-dimension ($\epsilon \in [-1, 1]$) and η_k is the step size of the kth pastoralist ($\eta \in \{0, (0.001 * Ub)\}$). Thereafter, the fitness of the kth pastoralist is evaluated, using Equation (10) followed by sorting and selection of new best pastoralist P'_{best} . For each split, the camp radius is reduced using Equation (11).

$$F(P'_k) = FF(P'_k) \quad (10)$$

$$r'' = r' / nP \quad (11)$$

Where, r'' is the camp radius of current iteration, and r' is the camp radius of previous iteration.

2.2.6 Merging

During merging, the best location within the camp is updated by comparing the all pastoralist best locations using Equation (12).

$$C_{best,v} = \begin{cases} P_{best}, & \text{if } P_{best} < P'_{best} \\ P'_{best}, & \text{otherwise} \end{cases} \quad (12)$$

Where, $C_{best,v}$ is the camp best location (that is the best pastoralist within the camp) at the vth splitting rate, $v \in [1: \beta]$. If all locations within the camp have been exploited, the Global camp best pastoralist $C_{Cbest,z}$ is obtained by sorting all $C_{best,v}$ and selection of best camp pastoralist. Where, $z \in \{1: \max_iteration\}$ else, splits again to new locations by repeating the steps in sub-section 2.2.5 and 2.2.6. If all maximum iteration not reached, the scouts' locations are updated again using Equation (3) followed by the processes in sections 2.2.2 to 2.2.6 are repeated. The Global

best pastoralist G_{best} is obtained by sorting $G_{cbest,z}$ and selecting the global best pastoralist. The steps involved in POA is summarized in Figure 1.

- i. Start
- ii. Initialize all POA parameters
- iii. Select scout pastoralist randomly from number of pastoralists and initialize scout location using Equation (3)
- iv. Evaluate the fitness of each scout, update scout locations and normalize scouts' locations within the search space until maximum scouting rate is reached (Equations (4, 5 and 6)).
- v. Select best camping location based and move pastoralist and herds to camp using Equation (7).
- vi. Evaluate fitness of pastoralist and determine best pastoralist within a camp P_{best} using Equations (8).
- vii. Split pastoralist to different locations within camp and evaluate fitness of each pastoralist using Equations (9 and 10).
- viii. Repeat step vii until maximum splitting rate is reached. For each split, divide the current camp radius by the number of pastoralist using Equation 11.
- ix. Update the best camp pastoralist C_{best} using Equation (12).
- x. If all regions within the search space have not been explored (maximum iteration not reached), update scout location using Equation (3) repeat steps iv to ix and update the global camp best pastoralist G_{cbest} .
- xi. Else, return the global best-found pastoralist G_{best} .
- xii. Stop

Figure 1: Proposed POA

3 EXPERIMENTAL RESULTS AND DISCUSSION

In this section, the experiments that were performed in order to evaluate the performance of the POA are presented. Two groups of test functions were selected to benchmark the proposed algorithm's performance, they are; Unimodal test functions (F1:F5) and the multimodal test functions (F6:F10). The dimension, range and the global optimum of each function is shown in Table 2 and their respective equations can be found in [17]. Unimodal functions have only a single global optimal solution. They are used to evaluate the algorithm exploitative capability, while multimodal test functions are used to evaluate algorithms exploration capability and ability to escape from getting stuck in local optima [8]. The algorithm was developed using MATLAB R2017a on a 64bit, 4Gig RAM computer.

Table 1: POA parameter settings

S/N	Parameter	Value
nP	Number of pastoralist	40
α	Scout rate	5
β	Split rate	30
r	Camp radius	$0.01*(Ub)$
Max-it	Maximun Iteration	1000
z	Number of runs	10

Table 2: Unimodal and Multi-modal Benchmark functions

Function ID	Function Name	Dim	Range	Global optimum
F1	Easom	2	[-100, 100]	-1
F2	Schaffer2	2	[-100, 100]	0
F3	Sphere	5	[-5.12, 5.12]	0
F4	Sum of different powers	5	[-1, 1]	0
F5	Sum Squares	5	[-10, 10]	0
F6	Ackley	5	[-32.768, 32.768]	0
F7	Beale	2	[-4.5, 4.5]	0
F8	Bohachevsky	2	[-100, 100]	0
F9	Cross-in-Tray	2	[-10, 10]	-2.06261
F10	Dejong N.5	2	[-65.536, 65.536]	0.998

For each function, the best (minimum), worst (maximum) and average values were recorded after 10 runs each of 1000 iterations. Other parameters of the algorithm that were used for the experiments are shown in Table 1. The results obtained were compared with some similar and successful NI metaheuristic optimization algorithms (BBO [3], ABC [4] and ICA [6]).

3.1 Unimodal Test Functions Results

Table 2 shows the result obtained using POA compared to results obtained using BBO, ABC and ICA for unimodal test functions. From Table 3, it can be seen that POA obtained the global optimum value for F1 and F2 and the values obtained for F3 and F5 are the closest to the global optimum than those obtained with BBO, ABC and ICA. POA only performs less better than all the other algorithms on F4. Also, Figure 2 shows that the algorithm converges faster than others except for F1. This result is an indication of POA high exploitation capability guaranteed by the camping strategy of the pastoralist. The results also show that POA is very competitive and can be an alternative when solving problems of similar nature.

Table 3: Unimodal Test Function Results

Function	Performance	POA	BBO	ABC	ICA
F1	Best	-1	-1	-	-
	Worst	-1	-1	-	-
	Average	-1	-1	-	-
F2	Best	0	0	0	0
	Worst	0	5.5589e-4	0	0
	Average	0	1.1118e-4	0	0
F3	Best	1.1094e-106	3.2204e-19	1.2476e-29	1.6191e-53
	Worst	6.2387e-106	6.2858e-18	8.5357e-28	4.7341e-39
	Average	3.7436e-106	2.0781e-18	3.6343e-28	1.0822e-39
F4	Best	1.6592e-18	0	2.4822e-43	0
	Worst	1.5912e	0	1.7314e	0

		-17		-40	
	Average	4.8783e-18	0	3.5475e-41	0
F5	Best	1.5201e-102	1.6418e-19	7.5983e-28	6.1524e-48
	Worst	3.5312e-102	4.5778e-16	9.6766e-27	1.7365e-37
	Average	2.6457e-102	9.2557e-17	3.2322e-27	3.4767e-38

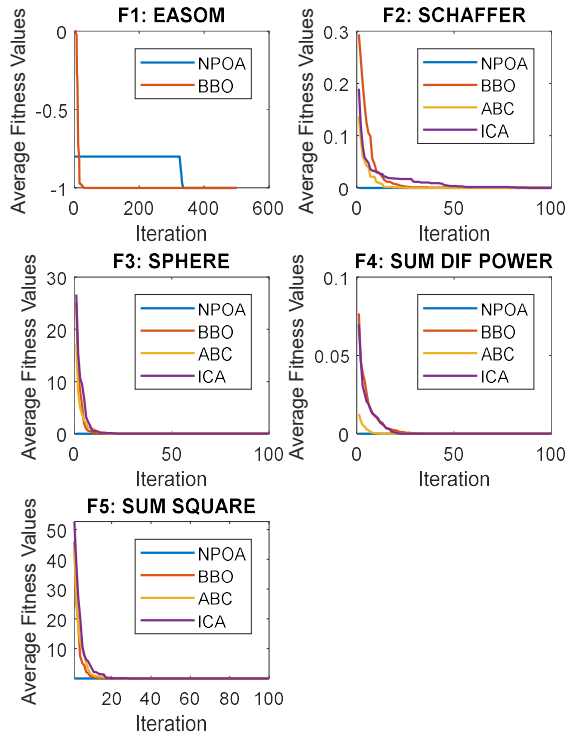

Figure 2: Convergence plot for Unimodal functions

3.2 Multimodal Test Function Results

Table 3 shows the result obtained using POA compared to results obtained using BBO, ABC and ICA for multimodal test functions. From Table 3, it can be seen that POA was able to obtain the global optimum for all the test functions. This is an indication of the algorithm high explorative ability and local optima avoidance. Also, the fast convergence rate of POA as shown in Figure 3 can be attributed to the effective scouting strategy of the pastoralist.

Table 3: Multi-modal Test Functions

Function	Performance	POA	BBO	ABC	ICA
F6	Best	-8.8818e-16	4.3991e-10	4.1108e-11	2.6645e-15
	Worst	2.6645e-15	5.0887e-9	1.0478e-10	6.2172e-15
	Average	-1.7764e-16	2.2748e-9	6.4982e-11	4.7962e-15
F7	Best	0	4.6577e-8	2.0226e-13	2.7325e-21

	Worst	0	3.3385e-6	1.1265e-11	1.4937e-11
	Average	0	1.1656e-6	1138e-12	3.4945e-12
F8	Best	0	0	-	0
	Worst	0	0.2183	-	0
	Average	0	0.0873	-	0
F9	Best	-2.0626	-2.0626	-2.0626	-2.0626
	Worst	-2.0626	-2.0626	-2.0626	-2.0626
	Average	-2.0626	-2.0626	-2.0626	-2.0626
F10	Best	0.998	0.998	0.998	0.998
	Worst	0.998	5.9288	0.998	0.998
	Average	0.998	2.7786	0.998	0.998

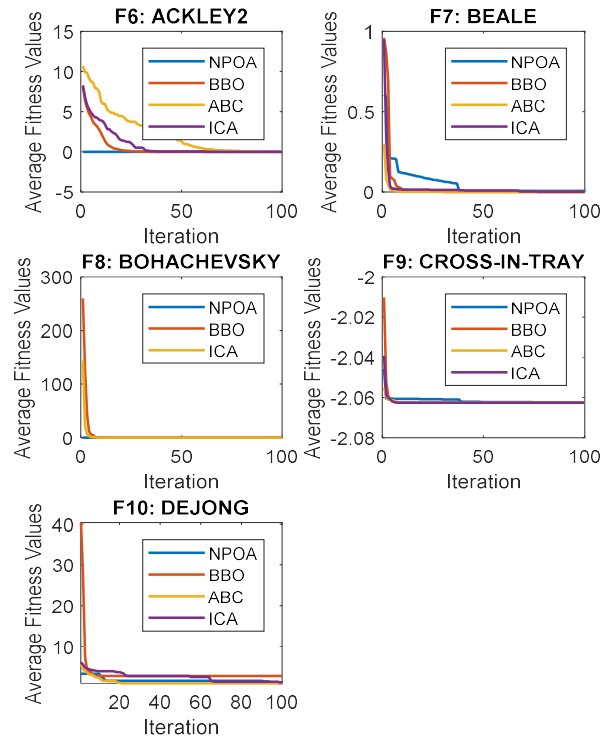

Figure 3: Convergence plot for Multimodal functions

3.3 Statistical Test Results

Table 4 presents the Wilcoxon rank sum nonparametric statistical test results that show how significant the obtained results are using a 5% (0.05) significance level [8]. The result indicated that there is no evidence (h = 0) to reject the null hypothesis of equal median between the observed and test samples at 5% confidence level. With P-Value of 0.5715, POA's results for all functions is highly significant (closer to the global optimum) followed by BBO (0.2577), ICA (0.1828) and ABC (0.0951).

Table 4: Wilcoxon Rank Sum Test Results

ALGORITHM	P-Value	h
POA	0.5715	0
BBO	0.2577	0
ABC	0.0951	0
ICA	0.1828	0

4 CONCLUSION AND RECOMMENDATION

A novel nature-inspired metaheuristic optimization algorithm that is inspired by the herding strategies of nomadic pastoralist is proposed in this paper. The performance of the algorithm was evaluated by benchmarking it on 10 unimodal and multimodal benchmark test functions. The results show that POA has high exploitation and exploration abilities with high convergence speed. When compared with other popular nature-inspired optimization algorithms, like BBO, ABC and ICA, the proposed algorithm outperforms all of the algorithms in most cases and provides competitive result in all cases. From the results of this study, it can be concluded that for the proposed POA:

- i. Exploration was guaranteed by scouting with longer step size.
- ii. Exploitation was guaranteed by camping with a shorter step size.
- iii. Local optima avoidance was guaranteed by splitting and merging within the camps.

For future studies using the proposed algorithm, it is recommended that;

- i. Several other benchmark functions (unimodal, multimodal and composite) should be tested to evaluate the algorithm ability to balance between exploration and exploitation.
- ii. Compare the results with those obtained from other popular population-based OA like Particle Swarm Optimization (PSO), Genetic Algorithm (GA).
- iii. Explore and model more nomadic Pastoralist strategies to improve the algorithm performance.
- iv. Apply the algorithm to solve real-world optimization problems.
- v. Investigate other movement strategies like the correlated random walk and levy flight which could improve the algorithm performance.

ACKNOWLEDGMENT

This work was supported in part by FUTMINNA under NEEDs Assesment Grant 2017.

REFERENCES

[1] N. Siddique and H. Adeli, "Nature Inspired Computing: An Overview and Some Future Directions," *Cogn Compu*, vol. 7, pp. 706-714, 2015.

[2] D. H. Wolpert and W. G. Macready, "No free lunch theorems for optimization," *IEEE Transactions on Evo-*

lutionary Computation 1, pp. 67-82, 1997.

[3] D. Simon, "Biogeography-based optimization.," *IEEE Transactions on Evolutionary Computation*, vol. 12, no. 6, pp. 702-713, 2008.

[4] D. Karaboga and B. Basturk, "A powerful and efficient algorithm for numerical function optimization: artificial bee colony (ABC) algorithm," *Journal of Global Optimization*, vol. 39, no. 3, pp. 459-471, 2007.

[5] R. V. Rao, V. J. Savsani and D. P. Vakharia, "Teaching-learning-based optimization: a novel method for constrained mechanical design optimization problems," *Computer-Aided Design*, pp. 303-315, 2011.

[6] E. Atashpaz-Gargari and C. Lucas, "Imperialist Competition Algorithm: An Algorithm for Optimization Inspired by Imperialistic Competition.," *In IEEE Congress on Evolutionary Computation (CEC 2007)*, pp. 4661-4667, 2007.

[7] S. Saremi, S. Mirjalili and A. Lewis, "Grasshopper optimisation algorithm: theory and application," *Adv Eng Softw*, vol. 105, p. 30-47, 2017.

[8] S. Mirjalili, "The Ant Lion Optimizer," *Advances in Engineering Software*, vol. 83, pp. 80-98, 2015.

[9] M. Yazdani and F. Jolai, "Lion Optimization Algorithm (LOA): A Nature-Inspired Metaheuristic Algorithm," *Journal of Computational design and Engineering*, vol. 3, pp. 24-36, 2016.

[10] D. G. Msuya, "Pastoralism Beyond Ranching: A Farming System in Severe Stress in Semi-Arid Tropics Especially in Africa," *Journal of Agriculture and Ecology Research International*, vol. 4, no. 3, pp. 128-139, 2015.

[11] M. Q. Sutton and E. N. Anderson, *Introduction to Cultural Ecology*, Plymouth, UK: AltaMira Press., 2010.

[12] J. Gerald and R. Dorothy, *Pastoralism in Practice: Monitoring Livestock Mobility in Contemporary Sudan, Kenya: United Nations Environment Programme*, 2013.

[13] C. Liao, P. E. Clark, S. D. DeGloria, A. Mude and C. B. Barret, "Pastoral mobility and policy recommendations for livestock herding in the Borana pastoral system in Southern Ethiopia," *Solutions Journal*, vol. 7, no. 5, pp. 17-20, 2016.

[14] d. G. Gert, "Taking Indegenious Knowledge Serious: The case of Pastoral Strategies Among Turkana Nomads of Northwest Kenya," *ILEIA Newsletter*, Eldoret, Kenya, 2011.

[15] H. K. Adriansen, "Understanding pastoral mobility: the case of Senegalese Fulani," *The Geographical Journal*, vol. 174, no. 3, pp. 207-222, 2008.

[16] S. Hagler, "Patterns of Selection of Human Movements I: Movement Utility, Metabolic Energy, and Normal Walking Gaits," *Quantitative Biology > Quantitative Methods (q-bio.QM)*, pp. 1-21, 2016.

[17] M. Jamil and X. S. Yang, "A literature survey of benchmark functions for global optimization problems," *Int. Journal of Mathematical Modelling and Numerical Optimisation*, vol. 4, no. 2, pp. 150-194, 2013.

Design and Implementation of a Microcontroller Based Auto-Switch Power Controller

Abideen A. Akanni, Abdulahi A. Badrudeen^{*}, Ojo A. Oluwaseun and Kudirat O. Jimoh

¹Department of Computer Engineering, Federal Polytechnic Ede, Nigeria

^{*}aabadrudeen@graduate.utm.my

Abstract—A number of cases have been reported where buildings were burnt down as a result of overheating of electrical household appliance(s) such as electric heater, electric cooker, which eventually led to explosion. Apart from that, the wastage of electrical energy and the damages associated with the manual switching of the household electrical appliances is a great concern which calls for immediate intervention. The above assertion prompts us to embark on developing an automation system. This paper therefore discusses a Microcontroller-Based Auto-Switch Power Controller (MBASPC) with an in-built timer as a better alternative that supercedes the manual switching of the household electrical appliances. It is configured to operate in single mode and dual mode. When in single mode, the OFF time duration is only required after which the device cuts off power supply from the connected appliance. When in dual mode, the ON/OFF time duration and connection modes are set while the device switches after each time duration elapses. Both the switching time and the mode can be reset and changed at any time by using the press buttons. The time duration and connection modes are displayed on the Liquid Crystal Display (LCD) while a 12V, 20A relay is used to switch the connected appliance(s). PIC16F377A Microcontroller is used to carry out the task and it is programmed in C language using Mikro C. The designed MBASPC capacity is 4KVA, specifically to power low load household electrical appliances. The device was tested and performed as expected.

Keyword— Electrical energy, Household electrical appliances, Microcontroller, Time duration, Liquid Crystal Display

1. INTRODUCTION

Electrical energy is rated as one of the greatest leading factors that drives any economy to substantial growth and development (Gbadebo and Chinedu, 2009). (Theophilus, Christopher *et al* 2016) opined that one importance of power supply is the fact that it has become equally indispensable as food supply. Energy is a necessity for both industrial and economic survival. In Loko's word (2009), electricity is the driving engine of any economy of the world. Aladejare (2013) posited that apart from serving as a pillar of wealth creation in Nigeria, electricity is also the nucleus of operations and subsequently the engine of growth for all sectors of the economy.

Today, electricity plays crucial role in the growth and development of any nation in the world and its continuous availability guarantees the country's growth. This makes it a very important factor in developing the economy and the standard of living of a country (Adeel, Mian *et al.*, 2016)

It is quite unfortunate that in most developing countries especially Nigeria, users of electricity are faced with the challenges of optimising electricity usage consequent upon human factors. Some household appliances are sometimes left connected to power supply for a longer period of time than necessary thereby wasting resources. A number of cases have been reported where buildings were burnt down as a result of overheating of electrical household appliance such as electric heater, electric cooker, boiler, which eventually led to explosion (Emmanuel, Samuel *et al*, 2016). In the same vein, some sensitive electronics devices like Laptop, smart phone and other valuable electronics devices are sometimes left overcharged re-

sulting in early damage of the device(s).

In the light of aforementioned, it is highly important to control the misuse of electrical energy at homes as well as in industries. Hence, the need for automation system. Automation is the technology through which a process or device is controlled with little or without human intervention (Groover, 2014) and Rifkin(1995)..This brought about the design and implementation of a Microcontroller-Based Auto-Switch Power Controller (MBASPC) as a better alternative device that supercedes the manual switching of the household electrical appliance(s). MBASPC prevents the wastage of electrical energy by ensuring the appliance consumes electrical energy only when required thereby minimizing the cost of electrical power consumption, protecting the appliance(s) and directly or indirectly preventing the electrical fire hazard.

2. METHODOLOGY

The design involved hardware module and software module. The hardware module comprises sub-modules such as the power supply unit, microcontroller unit, display unit and switch unit. All these units work together to form a single device. The software module consists of the programming language MikroC used in the design as shown in figure 1.

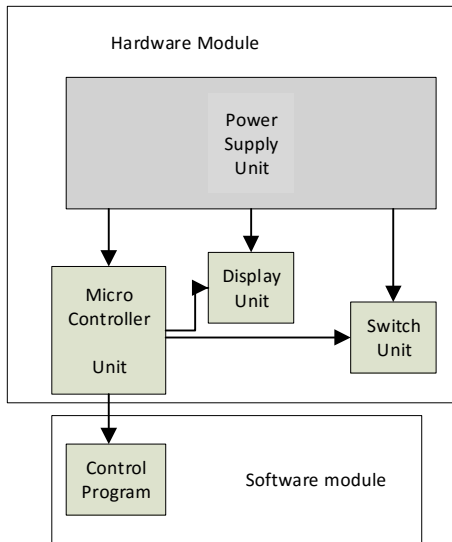

Fig.1: Block diagram of the designed project.

2.1 Hardware Module

2.1.1 Power Supply Unit

The microcontroller unit and the display unit are powered by a +5V d.c fixed regulated power supply using 7805 while the switch unit is powered by +12V d.c fixed regulated power supply using 7812. The power supply unit consists of: 220V/12V a.c step down transformer, Full wave bridge rectifier, +5V d.c regulator (7805), +12V d.c regulator (7812) and 2200µF Electrolytic capacitor

The 220V a.c mains power supply is stepped down to 12V and the bridge rectifier rectifies the a.c to d.c. Rectification is necessary for the purpose of converting a.c voltage to d.c voltage in order to supply power to the other units.

The capacitor is responsible for filtering any ripple coming out of the rectifying stage before it gets to the input of the regulator. There are two regulators in the circuit for regulating and maintaining a stable d.c output. The regulators used are the 7805 integrated circuit which provides +5V regulated d.c for the microcontroller unit and the display unit, and the 7812 integrated circuit which provides +12V regulated d.c for energizing the relay.

2.1.2 Microcontroller Unit

This unit consists of the buttons for the configuration of the device, and the PIC16F877A microcontroller which contains a set of instructions required in controlling the device. In modern day technology, electronic circuits involving microcontrollers are first simulated using computer software, before eventual implementation. A typical simulator application is The Proteus used for this project. The microcontroller has all the support chips incorporated inside its single chip and operates on a set of instructions (or the user program) stored in its memory. The microcontroller fetches the instructions from its program memory one by one, decodes these instructions, and then carries out the required operations.

2.1.3 Display Unit

This unit comprises 2x16 Liquid Crystal Display (LCD) which displays the countdown time and connection mode set by the microcontroller for the device. Liquid-crystal display (LCD) is a flat panel display that uses the light modulating properties of liquid crystals. Liquid crystals do not emit light directly. This module is monochrome and provides a 14-pin connector to the microcontroller

2.1.4 Switch Unit

This unit consists of the relay that is used to control the ON/OFF switch of the device. A 12V, 20A relay is used to achieve this. Relays are remote control electrical switches that are controlled by another switch, such as a horn switch or a microcontroller as in a power train control module. Relay allows a small current flow circuit to control a higher current circuit. Relay can process high power required to directly control an electric motor or other loads. Solid-state relays control power circuits with no moving parts, relays with calibrated operating characteristics have multiple operating coils that are used to protect electrical circuits from overload. In modern electric power systems these functions are performed by digital instruments still called protective relays

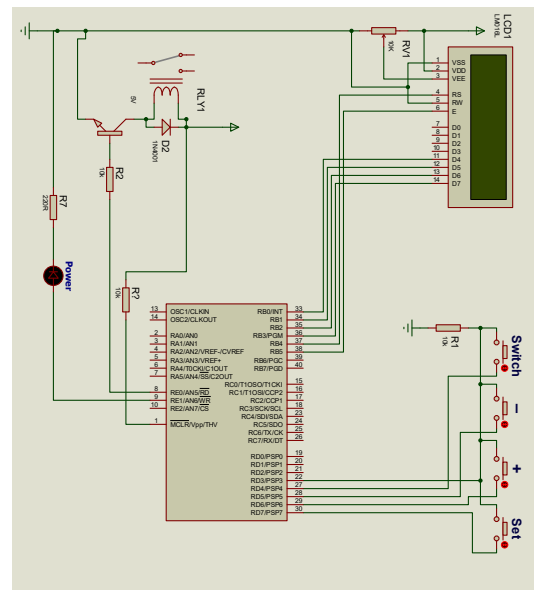

Fig. 2: Circuit diagram of the MBASPC

2.2 Software Module

The Microcontroller is nothing without the programming language. To accomplish any task on a microcontroller, there must be a set of explicit instructions. A collection of such instructions is called a program. The software module involves the programming language MikroC Pro-for-PIC, simulator (Proteus), and the integration of the microcontroller and program file (Hex File) using programmer. The choice of MikroC, for this project, is born out of the fact that, it is a portable language that requires minimal modification when transferring from one processor to another and also convenient for programming microelectronics.

2.3 Principle of Operations:

The buttons connected to the microcontroller perform various functions. The ON/OFF button is used to switch on and off the MBASPC. The select button is used to move the cursor to hour or minute before the time is been set. The enter button is used to send the selected time to the integrated circuit (IC) and start button commences the count-down. MBASPC has an in-built timer which does the countdown. Lastly, reset button is used to reset/restart the MBASPC device. The MBASPC has two terminals, one terminal is connected to the mains power supply while the device to be controlled is connected to the other end of the MBASPC. It is configured to operate in single mode and dual mode. When in single mode, the OFF time duration is only required after which the device cuts off power supply from the connected appliance.

When in dual mode, the ON/OFF time durations and the connection modes are set while the device switches after each time duration elapses. The switching time can be reset at any time using the press buttons while the mode can be changed anytime using the press buttons. The time duration and connection modes are displayed on the Liquid Crystal Display while a 12V, 20A relay is used to switch the connected appliance. PIC16F877A Microcontroller is used to carry out the task and it is programmed in C language using MikroC-Pro-for-PIC

2.4 Soldering of the Components on the Circuit Board

The tools used in soldering are a soldering iron, soldering flux and solder. The soldering iron bit is cleaned before and after use. The soldering iron tip is rubbed on a damp sponge after each solder.

During soldering, the surfaces were cleansed using soldering flux and the amount of heat was properly controlled, too much heat usually results in damage of components while insufficient heat results in dry joint which prevents the conduction of electricity.

3 SYSTEM TESTING AND RESULTS

The designed system was tested in order to ascertain its functionality. The instruments used include but not limited to digital multimeter, continuity tester etc. The various forms of tests that were carried out on the designed system are discussed in the next subsection

3.1 Out of Circuit Test

This refers to the test carried out on all the components used in the designed system before they are mounted on the board in order to ascertain their working condition. LEDs and resistors on the display module were tested using multimeter. The power supply unit voltage and current were measured with multimeter to verify the stabilization of the unit. Table 1 shows the output of the voltage and current

Table 1: Voltage and Current Output

Parameters	Voltage(Volts)	Current(Amps)
Input Voltage to the Transformer	220.00AC	
Output Voltage to the Transformer	9.00AC	
Output Voltage/current after Rectification	9.34DC	1.00
Output Voltage/current after Regulation	5.00DC	0.50

3.2 In-circuit Test

This test was carried out in order to confirm whether there is short circuit, open circuit, or no continuity in the circuit by using digital multimeter.

Short circuit test: When short circuit occurs, a very high current flows through the circuit which may tend to burn the component as a result of excessive heat that will be generated. When digital multimeter was used, nothing of such occurred.

- a. Open circuit test: No current flows in any open circuit. The implication is that there is a fracture or opening in the circuit. We did not experience it when tested with multimeter.
- b. Continuity test: The test was carried out on the various cables to confirm if there is any broken wire, by switching to ohm range the continuity tester. The instrument also certified the continuity test.

3.3 Testing the implemented device

It is very important to test the designed project to ascertain its functionality. The pin 11 and pin 12 of the microcontroller were fed with the required voltage 0V and 5V respectively while the circuit was observed to see how it worked. It is necessary that a supply voltage of 5V is maintained, otherwise, the voltage regulator is checked. Also, the microcontroller unit was tested using the control program, the display unit and the power supply unit were not left out in testing. The control program and the hardware soldering were checked, corrected until the system worked as expected.

4 PACKAGING

The device is housed in a plastic casing for proper compacting. The images of the device are shown in Figures 3 (a) and (b) as the internal and back elevation respectively.

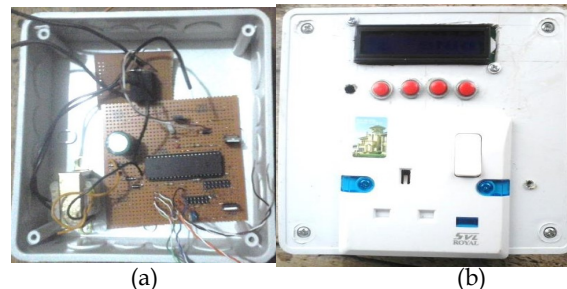

Figure 3: Internal Packaging of the circuit board (a) and the front view of the implemented device (b)

5 MBASPC and the existing Power Controller Systems

MBASPC is an improvement on Auto-Switch in TV set and some modern electric kettles which are configured to operate in single mode in which the off time duration is only required after which the Auto-Switch Power controller cuts off power supply. However, MBASPC is also configured to operate in dual mode in which the ON/OFF time duration is required whereby the MBASPC switches after each time duration elapses. Another aspect that can be compared with the MBASPC is the fixed delay in stabilizer to a predetermined time. The delay in MBASPC is not fixed. It is programmed in such a way that the delay can be reset or changed from time to time by the user. Apart from stabilizer, phase control circuit for power control in microwave oven involved repetitively triggering of the Triac at some fixed point. Power controller in the aforementioned systems cannot be compared with the MBASPC device in all ramifications.

6 CONCLUSION

Microcontroller-Based Auto-Switch Power Controller with an in-built countdown timer has been designed and constructed to control low load household electrical appliance(s) in such a way that it prevents the wastage of electrical energy by ensuring the appliance(s) consumes electrical energy only when required thereby minimizing the cost of electrical power consumption, protecting the appliance(s) and directly or indirectly preventing the electrical fire hazard. It is capable of controlling more than one household electrical appliance provided the total power of the appliance(s) is not more than 4.4kw which is the maximum power of the device. It has been tested and worked as expected.

7 RECOMMENDATION

MBASPC has same off time duration for all connected household electrical appliances. Future work can focus on a design that can have different off time durations for a set of connected appliances. High value components capable of enabling the designed system control very high loads should also be incorporated in order to make the system more functional in its modus operandi.

REFERENCES

- [1] Adeel A., Mian R (2016). Design and Implementation of Cost Effective Automatic Transfer Switch, International Journal of Engineering Research and General Science. Vol.4, issue 5, September-October, 2016.
- [2] Theophilus I, Christopher K. et al. (2016). Electricity Consumption and Industrial Production in Nigeria, Journal of Policy and Development Studies, vol. 10, No2, May 2016.
- [3] Gbadebo O. & Chinedu O (2009). Does energy consumption contribute to economic Performance? Empirical evidence from Nigeria, Journal of Economics and International Finance Vol. 1 (2), pp. 044-058, July 2009.
- [4] Aladejare S. (2013). Energy use and Economic Performance in Nigeria: An Empirical Study from Petroleum, Electricity and Dry Natural gas. International Journal of Physical and Social Sciences. <http://www.ijmra.us>, vol.3, issue 12.
- [5] Groover Mikel (2014). Fundamentals of Modern Manufacturing Materials processes and Systems.
- [6] Emmanuel K.A., Samuel K. et al (2016) Trend of Fire outbreaks in Ghana and Ways to prevent these incidents. Occupational Safety and Health Research Institute Published by Elsevier. An open access article under the CC BY-NC-ND license (<http://Creative Commons.org/license/sby-nc-nd|4.0|>)
- [7] Rifkin, Jeremy (1995) The End of Work: The Decline of the Global Labor Force and the Down of the Post Market Era. Putman Publishing Group pp 66 - 75.
- [8] Bernstein, G. H. (2009). "Microcontroller Applications", Microsoft® Encarta® 2009
- [9] Choudhary, H. (2014). Microcontroller Programmer/Burner. Online article at <http://www.engineersgarage.com/tutorials/microcontroller-programmer-burner>.
- [10] Grindling G. and Weiss B. (2007). Introduction to Microcontrollers
- [11] Paul, H. (2000). The Art of Electronics. London: Syndicate of the University of Cambridge.
- [12] Sudhakar K. S., A. A. Anil, K. C. Ashok and S. S. Bhaskar, (2013) Automatic Street Light Control System, International Journal of Emerging Technology and Advanced Engineering.

Performance Analysis of a Modified Otsu-based Constant False Alarm Rate (CFAR) Algorithm under Varying Signal to Noise Ratio in Radar Systems

Segun. Saliu*, Adeiza J. Onumanyi and Joshua A. Abolarinwa

Department of Telecommunication Engineering, Federal University of Technology, Minna, Niger State, Nigeria.

*s.saliu@futminna.edu.ng

Abstract— *The process of developing effective Radar target detection systems depends largely on the improved performance rate of the Constant False Alarm Rate (CFAR) technique deployed within the Radar system. These CFAR techniques typically estimate adaptive threshold values with the aim to maximize the probability of detection while maintaining the desired probability of false alarm. In this paper, we present a modified Otsu based CFAR algorithm that automatically estimates an effective adaptive threshold by processing each data sample within a given reference window for radar target detection. The performance of the proposed algorithm was evaluated using real-life acquired Radar return signals and the results obtained indicate that our algorithm performs similarly to the optimum (cell averaging) CA CFAR detector in a homogeneous environment, while typically outperforming other CFAR algorithms in similar conditions.*

Keyword— Adaptive, CFAR, Detection Probability, False alarm probability, Modified Otsu algorithm, Radar target, Threshold.

1. INTRODUCTION

A Radar system detects the presence or absence of targets by transmitting energy pulses into space [1]. The reflected pulses are then processed to determine the target presence or absence of targets within the scanning area [2]. In processing the received pulses, different algorithms use different methods to estimate the noise parameter within the signal, which is used to determine the power threshold also known as the detection threshold [3]. The accuracy of target detectors depends on how accurate the target processor is able to estimate this noise parameter. Different changing (Adaptive) threshold techniques have been proposed to estimate the noise power in order to maximize the probability of detection and to maintain a constant false alarm rate. Some of them include (mean level CFARs) such as CA CFAR processor which adaptively sets the threshold by estimating the mean level in a window of N range cells [4]. The CA-CFAR processor is the optimum CFAR processor that maximizes the probability of detection in a homogeneous background, but it experiences serious performance degradation at clutter edges and multiple target situations [3]. Some other mean level schemes were developed to alleviate the problems associated with the CA-CFAR like the greatest of CFAR (GO-CFAR) and the smallest of CFAR (SO-CFAR). The GO-CFAR has shown that in regions of clutter power transitions [5], only a minor increase can be expected in the false alarm rate; however the detector is incapable of resolving closely spaced targets. The SO-CFAR detector performs well in resolving two closely spaced targets but experiences performance degradation if interfering targets are located in both leading and lagging windows. Furthermore, the SO

CFAR processor also fails to maintain a constant false alarm rate at clutter edges [6].

Consequently, we consider the development of a new CFAR algorithm based on the Modified Otsu's algorithm [7]. The modified Otsu CFAR algorithm (MO-CFAR) unlike the mean level CFAR algorithms estimates the noise parameter by computing the specific index equivalent to the noise statistic from a computed between class variance in a window of N range cells. These N range cells surrounding the cell under test (CUT) are then used to set the adaptive threshold. The method has been shown to perform like the CA-CFAR in homogeneous background and experiences a lower false alarm rate than the other mentioned methods in heterogeneous background.

The rest of the paper is organized as follows: **Section 2** provides the basic assumptions description of the system model, **Section 3** provides an overview of the methodology, **Section 4** provides and discusses the results obtained, and the conclusion is provided in **Section 5**.

2. BASIC ASSUMPTIONS AND MODEL DESCRIPTION

In the CFAR detection scheme, the outputs from the square law detector device of the Radar system are sent serially into a shift register whose outputs are used by the modified Otsu algorithm to compute the test statistic, z (see Figure 1). In our model, the CFAR processor used by Gandhi in [3] has been replaced with the modified Otsu algorithm to compute the test statistic.

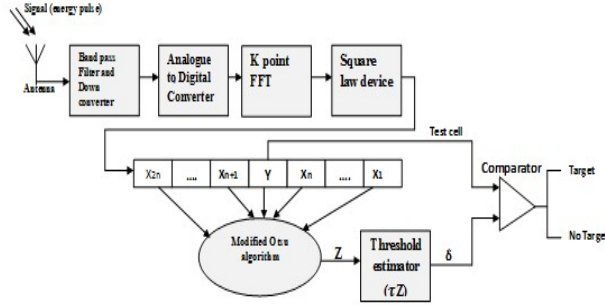

Figure 1: System model of the proposed MO-CFAR algorithm based on Modified Otsu algorithm.

Following Figure 1, a target is declared to be present H_1 if Y (the signal from the cell under test) exceeds the threshold τz and a target is declared absent H_0 if Y is less than τz . The (null hypothesis) H_0 defines a noise only or (target absent) condition, while the (alternate hypothesis) H_1 defines the signal plus noise or (target present) condition. Statistically, these hypotheses are defined as

$$H_0: Y(n) = W(n), \quad n = 1, 2, \dots, V \quad (1)$$

$$H_1: Y(n) = X(n) + W(n), \quad n = 1, 2, \dots, V \quad (2)$$

Where $W(n)$ is the additive white Gaussian noise (AWGN), n is the time sample index, v is the number of measured samples, $Y(n)$ is the received signal and $X(n)$ is the transmitted signal. In addition, despite being complex valued, we note that the real spectrum component of the noise is used in this case, and not the phase components. The value of V is computed using

$$V = 2^{\lceil (\log_2(Tf_s) - 1) \rceil} \quad (3)$$

Where T is total sensing period, and f_s is the sampling frequency. The signal's energy is computed using,

$$Y(k) = \left[\sum_{n=1}^V y(n) \cdot \exp(-j(\frac{2\pi}{T})nk) \right]^2, \quad k = 1, 2, \dots, V \quad (4)$$

Where k is the sampling frequency index, also note that the performance of the detector is evaluated using the probability of detection and the probability of false alarm given as

$$P_d = P(Y(k) > \tau z | H_1), \quad k = 1, 2, \dots, V \quad (5)$$

$$P_{fa} = P(Y(k) > \tau z | H_0), \quad k = 1, 2, \dots, V \quad (6)$$

3. DESCRIPTION OF THE PROPOSED MODIFIED OTSU BASED CFAR ALGORITHM

In this section, we describe the modified Otsu algorithm according to [6], which serves as the basis CFAR technique

for use in our work. Each step of the algorithm including its use as a CFAR technique for Radar purpose is described as follows:

Step 1: Sense the input signal, $y(n)$, $n = 1, 2, \dots, V$, and compute the energy of the signal as $Y(k)$, $k = 1, 2, \dots, V$. Then set of signal samples, $Y(k)$, $k = 1, 2, \dots, V$, representing a single spectral sweep, $S=1$ is sufficient to start the algorithm. In applying this step to radar target detection, note that we will only need to sense the input signal within a given sliding window of size N and compute the energy for a single sample set, then continue the process until the total sample set V is processed. This modification ensures that a single threshold is not computed for the total sample set as in the case of Onumanyi et al [7], but computed for a single sample.

Step 2: Set the number of histogram bins as $M = 256$.

Step 3: Obtain the set of sample counts per bin C_i , $i = 1, 2, \dots, M$, and the set of bin center values, B_i , $i = 1, 2, \dots, M$, for the one dimensional data, $Y(k)$, $k = 1, 2, \dots, V$, using,

$$(C_i, B_i) = F_D(Y(k), M), \quad D = 1 \quad (7)$$

Where the dimension, D , is now considered as $D = 1$, and $F_D(\bullet)$ is a normal histogram function. The syntax for calling this histogram algorithm in MATLAB is given as " $[C_i, B_i] = hist(Y(k), M)$ ".

Step 4: Compute the sample probability P_i for the j^{th} bin using

$$P_i = C_i / \sum_{i=1}^M C_i, \quad i, j = 1, 2, \dots, M \quad (8)$$

Step 5: Compute the set of sample cumulative probabilities, d_j for the j^{th} bin using

$$d_j = \sum_{i=1}^j P_i, \quad j = 1, 2, \dots, M \quad (9)$$

Step 6: Obtain the sample mean, μ_j , for the j^{th} bin using

$$\mu_j = \sum_{i=1}^M (P_i \cdot B_i), \quad j = 1, 2, \dots, M \quad (10)$$

Step 7: Calculate the total mean, ϵ using

$$\epsilon = \sum_{i=1}^M \mu_i \quad (11)$$

Step 8: Compute the set of between-class variance σ_j for the j^{th} bin using

$$\sigma_j = [(\epsilon \cdot d_j - \mu_j)^2 / d_j (1 - d_j)], \quad j = 1, 2, \dots, M \quad (12)$$

Step 9: Find the subset of the maximum between-class variance σ_z using

$$\sigma_z = \arg \max\{\sigma_j\}, \quad j \in M \quad (13)$$

This step ensures that the algorithm achieves an estimate

of the noise floor by searching for the threshold at the maximum between-class variance, by doing this, a form of noise variance estimation is done.

Step 10: Determine the specific index z of the subset with the condition

$$Z = R \text{ if } R \geq M/2 \text{ and} \quad (14A)$$

$$Z = E \text{ if } R < M/2 \quad (14B)$$

The condition specifies that when the measurement contains only noise samples (that is, if $R \geq M/2$) then the algorithm returns the upper bound, R , of the subset. However, if otherwise, the algorithm selects the lower bound index, E .

Step 11: Compute the detection threshold Δ using,

$$\Delta = \tau Z \quad (15)$$

Where τ is a constant threshold factor. This value was defined according to Gandhi [4].

$$\tau = (NP_{fa}^{-1/S} - 1) / (1 + S) \quad (16)$$

Where s is the signal to noise ratio.

4. RESULTS AND DISCUSSIONS

To evaluate the performance of the CFAR technique, the values of P_d and P_{fa} are computed according to Fawcett [8]. We computed the probability of detection P_d using

$$P_d = T_P / A_P \quad (17)$$

Where T_P is the number of truly detected signal samples and A_P is the total number of actual true signal samples. The probability of false alarm was computed using

$$P_{fa} = F_P / A_N \quad (18)$$

Where F_P denotes the falsely detected signal samples and A_N is the total number of actual noise samples.

Table 1: Performance analysis of the Modified Otsu (MO-CFAR) algorithm in varying snr conditions.

	Probability of Detection	Probability of False alarm
Noise Only	-	0.05
Signal plus Noise (2dB snr)	0.5	0.05
Signal plus Noise (5dB snr)	0.75	0.03
Signal plus Noise (10dB snr)	0.80	0.04

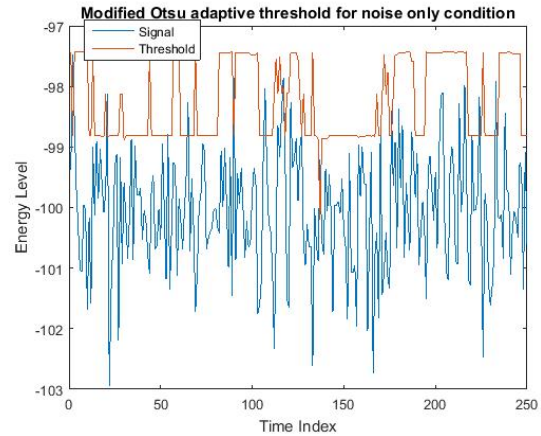

Figure 2: Detection thresholds for MO-CFAR algorithm in noise only condition.

4.1 Performance in the Noise only (target absent) condition H_0

To evaluate the noise only or target absent condition, a spectrum containing only noise was constructed by simulating an AWGN (Additive White Gaussian Noise) with zero mean and unit variance. The spectrum was computed for 250 samples using the detector in fig 1. In this condition we are most concerned with the probability of false alarm since a noise only spectrum is not expected to contain any radar target for detection. The figure 2 above is a graph that shows the estimated thresholds in this condition. It was seen in the table 1, that the modified Otsu based CFAR algorithm experienced a false alarm rate of 5% in this condition.

Note that, in all figures, the red lines signifies the detection thresholds while the blue ones corresponds to the signal amplitudes in decibels within a given time.

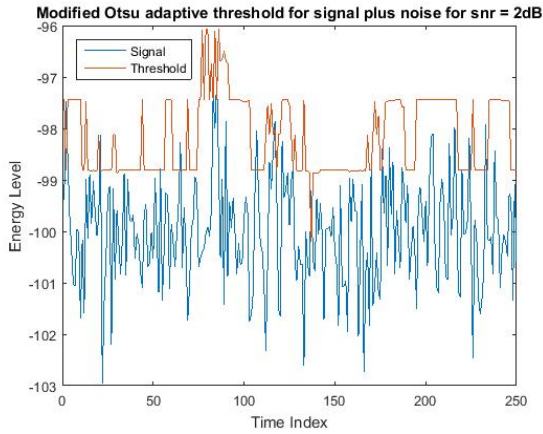

Figure 3: Detection thresholds for MO-CFAR algorithm for signal to noise ratio of 2dB.

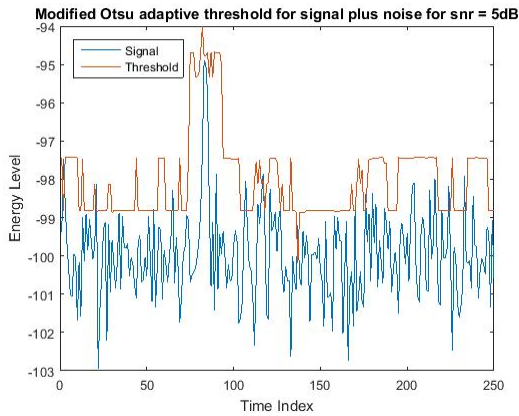

Figure 4: Detection thresholds for MO-CFAR algorithm for signal to noise ratio of 5dB.

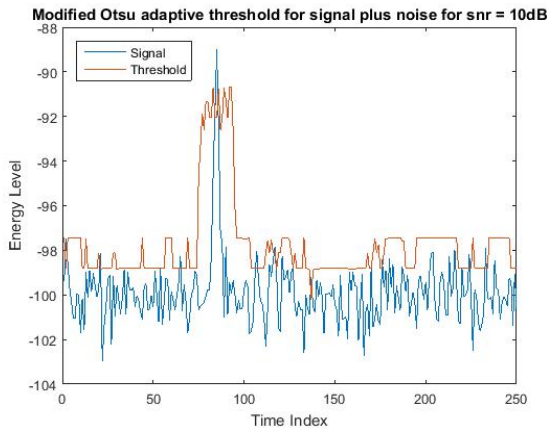

Figure 5: Detection thresholds for MO-CFAR algorithm for signal to noise ratio of 10dB.

4.2 Performance analysis in signal plus noise background H_1 of varying signal to noise ratio

To evaluate the algorithm’s performance under varying signal to noise ratio, we also simulated the condition by computing 250 samples of IID (independent and identical-

ly distributed) RVs (random variables) and varied the signal strength relative to a fixed noise level. The signal to noise ratio was varied from 2dB in figure 3 to 5dB in figure 4 and to 10dB in figure 5. The table 1, shows the detection probabilities, false alarm probabilities and the varying signal to noise ratio conditions. We observed that as the signal to noise ratio improved, there was a gradual improvement in the probability of detection as it experienced a detection probability of 50% at 2dB in (figure 3), 75% at 5dB in (figure 4) and 80% at 10dB in (figure 5). The algorithm also kept a false alarm rate of less than 6% in the entire varying signal to noise ratio conditions. The performance degradations at lower signal to noise ratio conditions is supported by similar results obtained by Datla in [9], suggesting that energy detectors often fail to distinguish signals from noise because of the noise uncertainty effect.

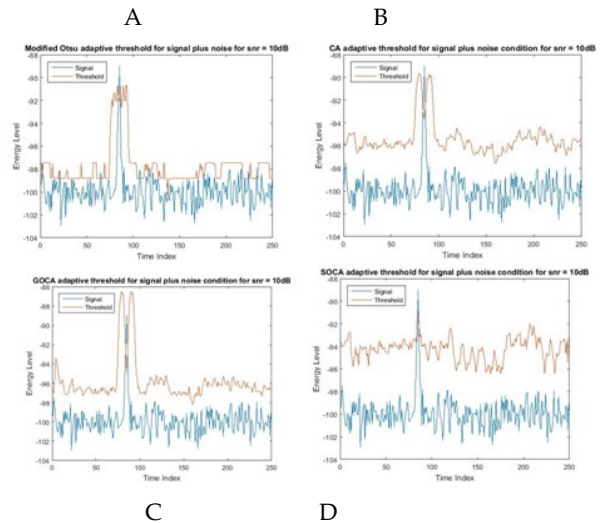

Figure 6: Detection thresholds for MO-CFAR, CA-CFAR, GO-CFAR and SOCFAR in a homogeneous signal plus noise H_1 or (target present) environment for SNR of 10dB

To evaluate the performance of the algorithm relative to other well known CFAR detectors, we simulated the signal plus noise homogeneous condition at a signal to noise ratio of 10dB, and computed the detection thresholds and their corresponding detection probabilities and false alarm probabilities. The techniques simulated and compared were, MO-CFAR, CA-CFAR, GO-CFAR and SO-CFAR. It was seen that the MO-CFAR in (figure 6A) had the highest detection probability of 80% with a corresponding false alarm probability of 0.04, exceeding the detection probabilities of CA-CFAR (figure 6B) and GO-CFAR (figure 6C) which had a detection probabilities of 60% respectively, with false alarm probabilities of 0.00 while the SO-CFAR (figure 6D) had a detection probability of 40% and a false alarm probability of 0.00 recording the lowest probability of detection.

Table 2: shows the detection probabilities and false alarm probabilities of the MO-CFAR, CA-CFAR, GO-CFAR and SO-CFAR in a homogeneous H_1 or (target present) environment.

	Probability of Detection	Probability of False alarm
MO-CFAR	0.80	0.04
CA-CFAR	0.60	0.00
GO-CFAR	0.60	0.00
SO-CFAR	0.40	0.00

5. CONCLUSION.

In this paper, we have presented a modified Otsu based CFAR algorithm for radar target detection and evaluated its performance in noise only and signal plus noise environment under varying signal to noise ratio conditions. The detection thresholds for the proposed CFAR were computed along with the detection probabilities and false alarm probabilities. Its performance in these environments showed that the modified Otsu based CFAR performance improved as signal to noise ratio increased.

REFERENCES

[1] FulvioGini "Introduction to radar processing" (2014).
 [2] Michael Parker. "Digital signal processing 101 second edition" (2017)
 [3] Gandhi P.P (1988) "Analysis of CFAR processors in non homogeneous backgrounds".
 [4] H.M. Finn, R.S. Johnson, Adaptive detection mode withthreshold control as a function of spatially sampled clutter-level estimate, RCA Rev. 29 (3) (1968) 414-467.
 [5] Hansen. V.G. and Sawyers.J.H. (1980) Delectability loss due to greatest of selection in a cell averaging CFAR.IEEE Transactions on Aerospace and Electronic Systems. AES-16 (Jan. 1980), 115-118.
 [6] Trunk, G.V. (1978) Range resolution of targets using automatic detectors. IEEE Transactions on Aerospace and Electronic Systems. AES-14 (Sept. 1978), 750-755.
 [7] Onumanyi A.J, OnwukaE.N, AibinuA.M (2017) "A Modified Otsu algorithm for improving performance of the energy detector in cognitive radio"Int J. Electron. Communication (AEÜ) 79 (2017) 53-63
 [8] Fawcett T. An introduction to roc analysis. Pattern RecognitLett 2006;27(8):861-74.
 [9] Datla D, Wyglinski AM, Minden GJ. A statistical approach to spectrum measurement processing. Inf TelecommunTechnology 2007.
 [10] Zaimbashi A. (2014) "An adaptive cell averaging

based detector for interfering targets and clutter-edge situations".
 [11] Hansen, V.G. (1973) Constant false alarm rate processing in search radars. In Proceedings of the IEEE 1973 International Radar Conference, London. 1973, pp. 325-332.
 [12] Otsu N. A threshold selection method from gray-level histograms.Automatica 1975;11(285-296):23-7.
 [13] Datla D, Wyglinski AM, Minden G. A spectrum surveying framework for dynamic spectrum access networks. IEEE Trans VehTechnol 2009; 58(8):4158-68.

Performance of the Recursive One-Sided Hypothesis Testing Technique under varying Signal to Noise Ratio Conditions in Cognitive Radio

J. O. Okonkwo*, A. J. Onumanyi, B. A. Salihu, H. Bello Salau, S. S. Oyewobi

Dept. of Telecommunication Engineering, Federal University of Technology, Minna, Niger State, Nigeria

*james.okonkwo2@gmail.com

Abstract— *The Recursive one-sided hypothesis testing technique (ROHT) is one notable example of an Adaptive threshold estimation technique (ATT) for energy detection in Cognitive Radio (CR). It is known to compute accurate threshold values based on the proper choice of its parameter values, namely the coefficient of standard deviation and the stopping criteria. However, determining the performance limits of the ROHT algorithm with regards to its minimum Signal to Noise Ratio (SNR) level remains an unexplored exercise in the literature. Thus, in this paper, a preliminary study of the ROHT algorithm is carried out to examine the effect of varying SNR conditions on the performance limit of the algorithm. The algorithm was evaluated using signals varied from SNR = 10 dB down to 1 dB. It is shown that below the SNR = 3dB margin, the performance of the ROHT may no longer be guaranteed for effective detection performance. Hence the need to improve the performance of the ROHT algorithm for use in CR, using adaptive optimization technique.*

Keywords— Adaptive; Cognitive Radio; Energy Detector; Recursive One-sided Hypothesis Testing; Threshold

INTRODUCTION

A cognitive radio (CR) is a wireless communication radio that intelligently senses its Radio Frequency (RF) environment for the presence/absence of Primary User (PU) signals, and uses the vacant channels for opportunistic communication while vacating occupied channels to avoid interference [1], [2]. The concept of CR was first introduced by Joseph Mitola III in 1999 [3], in which he proposed CR for opportunistic communication based on the use of Software Defined Radios (SDRs). CRs are intended to obtain the best available spectrum for communication through the use of cognitive abilities and re-configurability characteristics. In this case, cognitive ability refers to the capacity of the secondary user (SU) to sense radio conditions within its immediate RF environment, while re-configurability infers the ability to adjust its transmission frequency and power, bandwidth and modulation scheme.

Typically, CRs acquire spectra information via the use of Spectrum Sensing (SS) techniques. The use of SS is specified in the IEEE 802.22 draft standard for Wireless Regional Area Network (WRAN) [4], [5]. It specifies several methods for SS namely, the Interference Temperature Detection method, the Matched Filter Detection method, the Cyclostationary Feature Detection method, and the Energy Detection (ED) method. However, the ED is considered the most viable SS technique mainly for its ease of deployment, low computational power, low complexity and its independence of the Primary User (PU) signal waveform [6].

Newer ED designs are required to adapt their respective threshold values in accordance with varying channel conditions. This has led to the design of several adaptive threshold estimation techniques (ATT) in the literature [6]–[9] with the Recursive One-Sided Hypothesis Testing (ROHT) algorithm being one of the most viable algorithms

for use in the ED [10], [11]. The ROHT is known for its simplicity, effectiveness and efficiency [10]–[13]. However, determining the performance limits of the ROHT algorithm with regards to its minimum Signal to Noise Ratio (SNR) level remains an unexplored exercise in the literature. This knowledge will enable users to determine particular conditions below which the ROHT's performance may no longer be guaranteed.

Thus, in this paper, we present a preliminary study of the ROHT algorithm to examine the effect of varying SNR levels on its performance limits. It is noted that the ROHT has an SNR limit below which its performance may not be guaranteed for use in the ED. The rest of the paper is structured as follows: Section 2 provides a brief overview of ROHT algorithm, exposition of the ROHT model and its process of operation. Section 4 presented the results and discussion, while the Section 5 provides the conclusion that was drawn.

2. THE SYSTEM MODEL

The detection system under consideration in this work is represented in Figure 1. Typically, we considered the reception of a Radio Frequency (RF) signal emanating in a typical wireless radio environment. These signals are received at the front end of the energy detection system via an antenna designed to operate within a specified frequency range(s), for example, within the VHF/UHF band to detect TV white spaces. The received continuous waveforms, $y(t)$, are passed into the energy estimator block where filtering and analogue to digital conversion takes places. To obtain the frequency domain version of the input signals, the energy estimator block computes the Discrete Fourier Transformation (DFT) of the signal. It then conducts a squaring operation and an averaging function to obtain $Y(n)$.

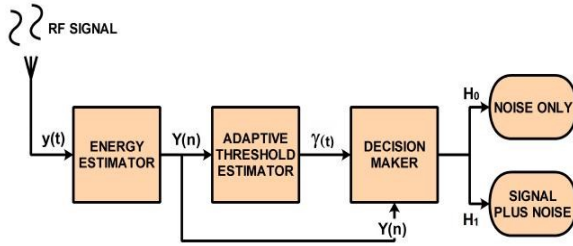

Figure 1: The Energy Detection System

The energy samples, $Y(n)$, are considered to be the test statistic in this case. These samples are passed into the adaptive threshold estimator block to dynamically compute an appropriate threshold value, $\gamma(T)$; which is a function of a certain sensing period, T . The test statistic, $Y(n)$, is compared to γ , to determine the state of the channel. If the channel is vacant ($Y(n) < \gamma$), then H_0 is declared implying that the channel contains only noise samples, and if the channel is occupied ($Y(n) \geq \gamma$), then H_1 is declared implying the presence of signal plus noise in the channel. These hypothesis are generally defined as:

$$H_0: Y(n) = W(n), \text{ for } n = 1, 2, \dots, N \quad (1)$$

$$H_1: Y(n) = X(n) + W(n), \text{ for } n = 1, 2, \dots, N \quad (2)$$

Where n denotes the frequency sample index, N is the total number of frequency samples, $X(n)$ represents the transmitted PU signal, $W(n)$ is modelled as Additive White Gaussian Noise (AWGN), and $Y(n)$ denotes the energy of the received signal at the output of the energy estimator.

3. THE ROHT ALGORITHM

The Recursive One-Sided Hypothesis testing (ROHT) algorithm is considered for use in the adaptive threshold block of Figure 1. We describe in this section the process involved in the ROHT algorithm. The flow chart of the ROHT threshold computation process is presented in Figure 2 [11].

The algorithm begins by initializing the set of signal components within the received energy measurements. It is assumed that the received measurement contains more noise components than signal components and thus the purpose of the ROHT is to disprove this hypothesis. The algorithm then proceeds to set the initial decision threshold which is given as a function of the standard deviation coefficient, z -value, the standard deviation, and the mean of the energy samples in the i^{th} iteration. Based on the z -value and the initial threshold, the algorithm assumes that a given percentage of the energy samples on the right hand side of the normal Gaussian distribution belongs to the signal components, while considering other samples to the left hand side of the distribution as noise components. The identified signal portions are discarded and the process repeats. The algorithm comes to a halt once the difference in the standard deviation between two consecutive iterations is less than a specified random positive value given as β . The estimated threshold, the mean and the standard

deviation are considered to be the final values for the entire frequency band under consideration at a time. The following pseudo code is presented for the ROHT algorithm [11]:

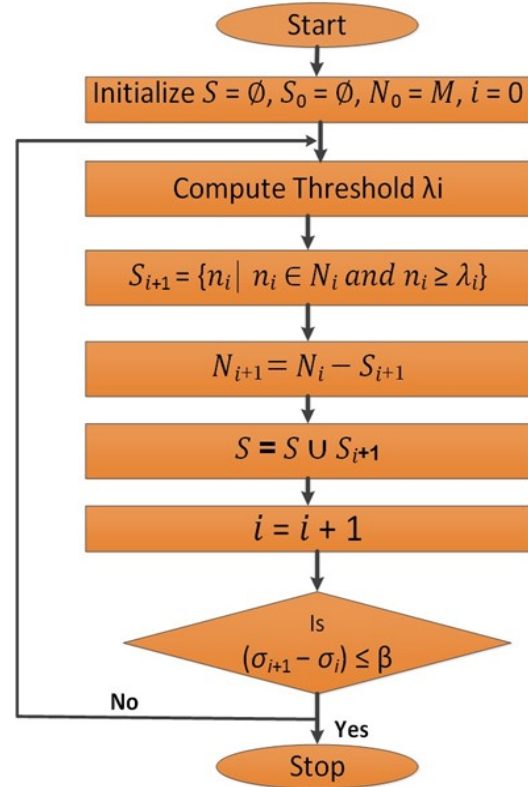

Figure 2: The ROHT Algorithm [11]

- I. Initialize $S = \emptyset, S_0 = \emptyset, N_0 = M, i = 0$
- II. Do
 - 1) $\lambda_{i+1} = z\text{-value} * \sigma_i + \mu_i$
 - 2) $S_{i+1} = \{n_i \mid n_i \in N_i \text{ and } n_i \geq \lambda_i\}$
 - 3) $N_{i+1} = N_i - S_{i+1}$
 - 4) $S = S \cup S_{i+1}$
 - 5) $i = i + 1$
- III. Until $(\sigma_{i+1} - \sigma_i) \leq \beta$

4. RESULTS AND DISCUSSION

In this section, we present results from the training and testing phases of the ROHT algorithm. The algorithm was trained with simulated noise only signals to ascertain the algorithm's parameter values. In this case, the false alarm rate is of utmost concern to the CR engineer, so we note that the fixed parameter values cannot be changed during the testing phase, which models a real life deployment scenario. After the training phase, the ROHT algorithm was evaluated based on signal plus noise datasets with varying signal-to-noise (SNR) levels.

4.1. Training with the noise only condition, H_0

To determine the false alarm rate and to show how the

ROHT algorithm performed in noise only condition, we simulated a sensed spectra containing $N = 250$ samples of only Additive White Gaussian Noise (AWGN). A representation of this noise only spectra (a single sweep) is shown in Figure 3. The parameters of the ROHT algorithm were iteratively tuned until we arrived at an effective value of z - value = 2.5 and $\beta = 0.5$, respectively. The probability of false alarm of $P_{FA} = 0.04$ achieved for these values were read off the performance curve shown in Figure 4.

4.2. Performance in the signal plus noise condition, H_1

To demonstrate the performance of the ROHT algorithms under different SNR conditions, we simulated an FM signal, and we varied the signal strength relative to a fixed noise level. The SNR was reduced from a high SNR level (SNR = 10dB) to a low SNR level of 1dB. In this work, an SNR of 0dB was not considered because it implies that the signal is totally buried in the noise. It is noted in [12] that sensing below SNR = 0dB is a difficult task for an ED in CR especially when the ED has no knowledge of the noise floor nor the PU's frequency. The threshold estimated by the ROHT algorithm for each SNR condition is presented in Figure 5 and Figures 7–9, while the

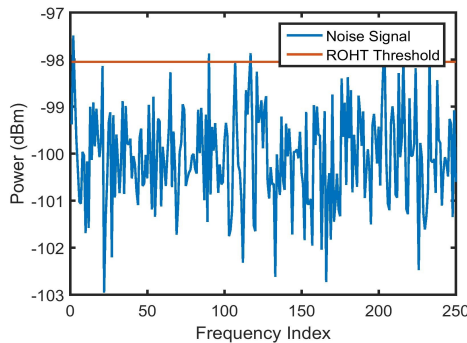

Figure 3: Noise only spectra showing the threshold estimated using the ROHT algorithm

performance curves for the signal plus noise conditions is shown in Figure 6. It is shown in Figure 5 that the estimated threshold effectively detects the signal samples for the SNR = 10 dB condition, while clearly lying above the noise level. Similar characteristics are shown in Figures 7 - 9 for the SNR = 5 dB, SNR = 3 dB and SNR = 1dB conditions, respectively. However, below the SNR = 3dB, particularly at SNR = 1dB, the threshold is shown to miss the very low signal samples,

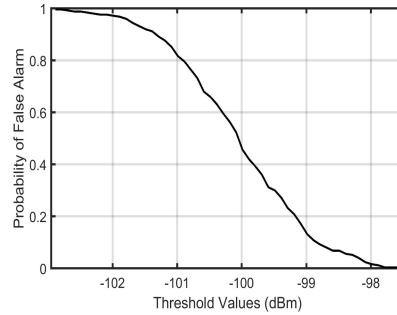

Figure 4: The probability of false alarm computed for the noise only dataset based on a true threshold value of -97 dBm.

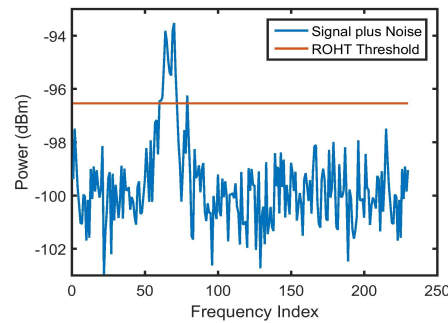

Figure 5: Signal plus noise spectra at SNR = 10dB showing the threshold estimated by the ROHT algorithm

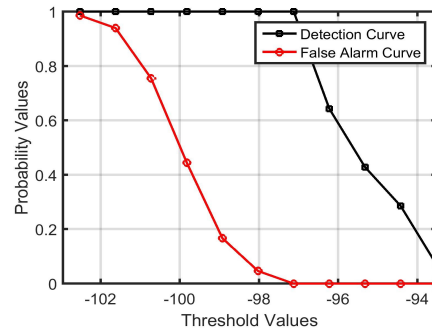

Figure 6: Performance for the Signal plus Noise dataset for (SNR=10dB to 1dB)

nevertheless maintaining a good false alarm rate by lying above the noise level. This preliminary results indicate that the ROHT algorithm estimates effective thresh-old values only until the SNR = 3dB condition, below which the detection performance of the algorithm may no longer be guaranteed to meet the IEEE 802.22 re-quirement given in [5].

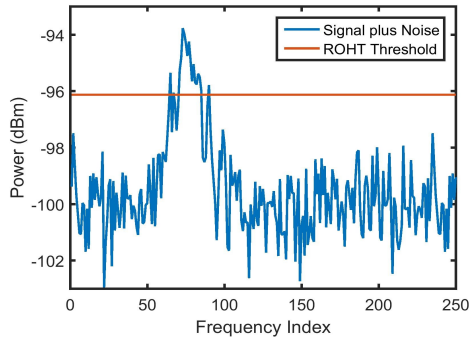

Figure 7: Signal plus Noise spectra at SNR = 5 dB showing the threshold estimated by the ROHT algorithm

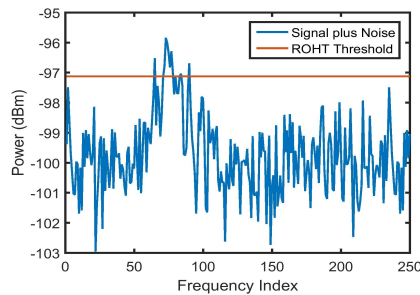

Figure 8: Signal plus Noise Spectra at SNR = 3 dB showing the threshold estimated by the ROHT algorithm

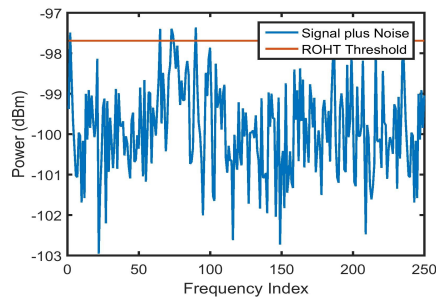

Figure 9: Signal plus Noise spectra at SNR = 1dB showing the threshold estimated by the ROHT algorithm

5. CONCLUSION

The ROHT algorithm has been presented and evaluated under different SNR conditions ranging from SNR = 10 dB down to SNR = 1 dB. The results obtained indicate that the performance of the ROHT algorithm may not be guaranteed below the SNR = 3 dB. These results will be valuable in the design of effective adaptive energy detection systems for spectrum sensing in CR. Further research will be carried out to develop automatic and optimized methods for improving the performance of the ROHT algorithm in low SNR conditions.

REFERENCES

[1] I. F. Akyildiz, W. Y. Lee, M. C. Vuran, and S. Mohanty, "Next generation/dynamic spectrum access/cognitive radio wireless networks: A survey," *Computer Networks*, vol. 50, pp. 2127–2159, 2006.

[2] T. Yucek and H. Arslan, "A survey of spectrum sensing algorithms for cognitive radio applications," *IEEE communications surveys & tutorials*, vol. 11, no. 1, pp. 116–130, 2009.

[3] J. Mitola and G. Q. Maguire, "Cognitive radio: Making software radios more personal," *IEEE personal communications*, vol. 6, no. 4, pp. 13–18, 1999.

[4] H. Hu, H. Zhang, H. Yu, and Y. Chen, "Spectrum-energy-efficient sensing with novel frame structure in cognitive radio networks," *AEU - International Journal of Electronics and Communications*, vol. 68, no. 11, pp. 1065–1072, Nov. 2014.

[5] IEEE802.22, "Enabling broadband wireless access using cognitive radio technology and spectrum sharing in white spaces," *IEEE 802.22 Working Group on Wireless Regional Area Networks*, 2011.

[6] C. Liu, M. Li, and M.-L. Jin, "Blind energy-based detection for spatial spectrum sensing," *IEEE Wireless Communications Letters*, vol. 4, no. 1, pp. 98–101, feb 2015.

[7] B. K. Jariwala and V. R. Manilal, "A Survey: A Cognitive Radio for Wireless Communication," *IOSR Journal of Electronics and Communication Engineering*, vol. 9, no. 1, pp. 57–63, 2014. [Online]. Available: <http://www.iosrjournals.org/iosr-jece/papers/Vol9Issue1/Version-4/L09145763.pdf>

[8] R. K. Dubey and G. Verma, "Improved spectrum sensing for cognitive radio based on adaptive double threshold," *International Journal of Emerging Trends in Electrical and Electronics (IJETEE)*, vol. 11, no. 2, pp. 1–6, 2015.

[9] A. Chavez, R. Littman-Quinn, K. Ndlovu, and C. L. Kovarik, "Using tv white space spectrum to practise telemedicine: A promising technology to enhance broadband internet connectivity within healthcare facilities in rural regions of developing countries," *Journal of telemedicine and telecare*, vol. 22, no. 4, pp. 260–263, 2016.

[10] D. Datla, A. M. Wyglinski, and G. J. Minden, "A statistical approach to spectrum measurement processing," *Information and Telecommunications Technology*, 2007.

[11] D. Datla, A. M. Wyglinski, and G. Minden, "A spectrum surveying framework for dynamic spectrum access networks," *IEEE Transactions on Vehicular Technology*, vol. 58, no. 8, pp. 4158–4168, 2009.

[12] A. J. Onumanyi, E. N. Onwuka, A. M. Aibinu, O. C. Ugweje, and M. J. Salami, "A modified Otsu's algorithm for improving the performance of the energy detector in cognitive radio," *AEU - International Journal of Electronics and Communications*, vol. 79, pp. 53–63, 2017. [Online]. Available: <http://dx.doi.org/10.1016/j.aeue.2017.04.013>

[13] A. J. Onumanyi, E. N. Onwuka, A. M. Aibinu, O. C. Ugweje, and M. J. E. Salami, "A real valued neural network based autoregressive energy detector for cognitive radio application," *International Scholarly Research Notices*, vol. 2014, pp. 1–11, 2014.

ENGINEERING AND ENGINEERING TECHNOLOGY

Tribological Properties of Untreated Vegetable Oils as Automotive Shock Absorber Fluids

Binfa Bongfa^{1,2*}, S. Syahrullail², M.K. Abdul Hamid², P.M. Samin² and M. O. Adeoti³

¹School of Engineering, Federal Polytechnic Idah, 271101 Idah, Kogi State, Nigeria

²Faculty of Mechanical Engineering, Universiti Teknologi Malaysia, 81310 UTM Skudai, Johor, Malaysia

³Department of Mechanical Engineering, Federal Polytechnic Bida, 612101 Bida, Nigeria

*engrbinfabongfa@gmail.com

Abstract— *Automotive shock absorber fluids (ASAFs) serve in automotive hydraulic-type shock absorbers as damping fluids, lubricants, and coolants. Conventional ASAFs are petroleum-derived base oil(s) treated with additives, both of which are scarce, costly, and environmentally non-conforming. In this work, the tribological properties of atili oil, coconut oil, and groundnut oil were investigated on a Four-Ball Wear Tester (in accordance with ASTM D4172–94 method) as alternative basestocks for vehicle ASAFs. The vegetable oils, compared with a commercial petroleum-derived ASAF, showed superior friction reduction, and appreciable wear control. These results showcase these vegetable oils as suitable alternative base-stocks for this application.*

Keyword— Vegetable Oils, Automotive Shock Absorber Fluids, Friction, Wear, Four-ball Wear Tester

1 INTRODUCTION

AUTOMOTIVE shock absorber fluids (ASAFs) are included in cylinders of automotive hydraulic-type shock absorbers to serve as damping fluids, lubricants, and coolants. ASAFs are manipulated by the shock absorber mechanisms to convert the energy of the spring, located on the suspension, to absorb heat and dissipate it to the surrounding [1]. Conventional ASAFs are composed of basestocks blended with additives. The basestocks as well as the additives used in formulating these fluids are petroleum-derived or synthetic. So far, scholarly publications revealed two crop oil-based ASAFs. One including only 37% blown rapeseed oil [2], and the second including monounsaturated fatty acids esterified with 2-alkyl-1-alkanol [3], a petrochemical and oleochemical industrial product [4]. The former still post relatively high environmental problem while the latter is expensive, and susceptible to corrosion and foaming. The prospect and possibilities of formulating ASAFs using vegetable oils (VOs), because of their promising physico-chemical properties and response to additives have been reviewed [5], but no work has established their suitability from tribological point of view.

While viscosity is a primary parametric requirement for suitable viscous damping in automotive shock absorbers, the ASAF is of utmost necessity required to reduce to an acceptable level, mechanical friction between contacting relative moving surfaces of the shock absorber components (in order to reduce the generation of heat and coulomb damping), and to control wear of the same. In this work, the performance of vegetable base oils in controlling mechanical friction, and wear of automotive shock absorber components have been investigated on a Four-ball Wear Tester in accordance with ASTM D4172–94 test method.

2 MATERIALS AND METHODS

THE VOs used in this work are atili oil (ATO) (a specie of canarium schiveinfurthii), coconut oil (CNO), and groundnut oil (GNO) purchased from local markets within Nigeria. The benchmark fluid is a petroleum-based commercial shock absorber fluid obtained from a market in UK. SKF steel ball bearings of 12.7 mm diameter, 0.1 μ m C.L.A. surface roughness, 62 HRC Hardness, and chemical composition, 87.21% Fe, 10.2% C, 0.06% Ni, 1.46% Cr, 0.42% Mn, 0.07% S, 0.12% P, and 0.45% Si were obtained from a marketer in Malaysia.

The friction and wear tests were performed on a Four-Ball Wear Tester in accordance to ASTM D4172-94 test method (detail description is in [6]). After each test, the coefficient of friction (CoF) of the tribo-contact was extracted from the machine interface software on the computer and reported, while the wear scar diameters (WSDs) and the worn surface morphology were measured using a high resolution scale, (x100) and (x500) respectively, of an optical microscope. Two WSDs, one perpendicular and the other along the striations of each of the three lower balls were measured using the microscope and the average of the six readings recorded as the WSD (mm). The average surface roughness (Ra) of one of the three lower balls in each of the tests was determined using a surface roughness tester (stylus profiler-type).

3 RESULTS AND DISCUSSION

THE friction reduction performance of the nominated VOs, and the reference ASAF were expressed based on CoFs reported in Figure 1. The shorter the bar, the lower and more preferable the CoF. It can be seen from the chart (in Figure 1) that all the untreated vegetable oils (ATO, CNO, and GNO) have better friction reduction capacities than the reference fluid (COM), as seen between the tribo-contact of the balls. Among the vegetable oil samples, ATO

has the lowest CoF (hence it is the best in-between-the-balls lubricant in terms of friction reduction) followed by (GNO, while CNO has the highest (being worst) CoF. The better performance by the vegetable oils in friction reduction is due to their amphiphilic nature, consisting of a long non-polar hydrocarbon chain (hydrophobic) and a polar head (hydrophylic), giving them strong positive effects on boundary lubrication [4]. The amphiphilic characteristics which is responsible for their high polar nature give them superior "oiliness", and affinity to metal surfaces compared to the petroleum-derived oils [7].

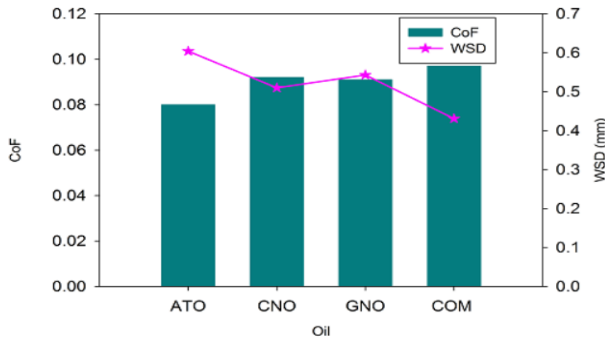

Figure 1: Plot of CoF and WSD of the tribo-contacts lubricated with the studied oils

This polar nature enables VOs absorb tenaciously with thin shearable films on metal surfaces, such that the oil molecules could sufficiently lubricate contacting faces of components designed with very low intervening spaces. The structure of arrangement of vegetable oil molecules in a tribo-contact zone is in such a manner that the highly reactive polar heads of the molecules get attached with strong orienting forces to the metal surface, while the long hydrocarbon ends stick away in a perpendicular array to the said surface [8]. The orientation enables these molecules to provide a slippery layer that hinders asperities-asperities contacts, and even when the arrayed layers are sheared off due to rubbing of the surfaces, they are quickly and simply recovered to their original estate by the strong orienting forces.

The behaviour of the CoF with time of the tested oil samples are presented in Figure 2. From the curves, the crop oils showed reducing CoFs with time, implying continuous increase of difficult-to-compress, but shearable films. ATO leads in this performance, followed by GNO. CNO is barely better than the COM in this performance. These abilities to produce stable and difficult-to-compress, but shearable thin-film attachments on interfaces of boundary lubricated tribopairs showed by the crop oils could give them recommendation as suitable ASAFs. Secondly, high reduction of friction between the relative moving contacting surfaces by these natural oils implies reduced heat generation owing to mechanical friction, compared to internal friction forces in the fluid. In such a situation, the metal elements may even extract heat generated by the fluid. This will contribute immensely to elongating the service life duration of the bio-based oils, and invariably the lubricated system, especially in non-refillable automotive shock absorbers where the life of the fluid is to a large extent the service-life of the unit. A well reduced mechanical friction in automotive shock absorbers also

implies smoother ride quality. The superior performance of ATO in friction moderation connotes that the hydrogen-bonded polar matrix produced by the oil possesses superior resilience, and could much easily and quickly get restored unto the interfaces of the balls after being sheared by the load applied, compared to those of GNO and CNO. It is also traceable to the high stearic and palmitic content in its saturated fatty acids, and its long polar chains; the components reported to be very effective in friction reduction [4]. On the other hand, the high level of lauric and palmitic acid, and low unsaturated acids in CNO, coupled with its short chains can be the reasons for its poor friction modification ability. GNO, due to its moderate level of stearic and palmitic acids, and probably longer chain than those of CNO, but lower in both than ATO, occupied a mid-way performance in friction reduction.

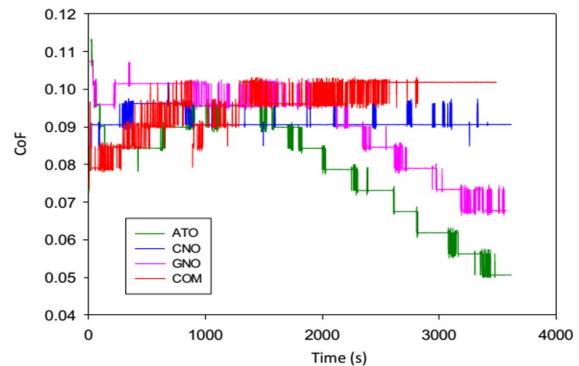

Figure 2. Variation of CoF of studied oils with time

Although the VOs have shown superiority over the commercial oil in lubricity, their capacity for retention of this property for a sufficient part of their service life in the desired application cannot be guaranteed. This is majorly due to the tribo-chemical transformation that do take place in them under severe service conditions, when temperature, metal surface, shear stress, pressure and service environment become applicable at the same time [4], and elevate the surface energy at the tribo-contacts. The rise in surface energy normally results in the desorption of the friction moderating molecules or films from the contacting faces of the tribocouple. If this occurs in an automotive shock absorber in service, it can give rise to asperities-asperities contacts at the cylinder-piston, rod-oil seal, and rod-rod guide interfaces, resulting in speedy increase of mechanical friction load. This friction can contribute to damping through coulomb effect, but to several disadvantages, including wear, poor ride quality, locking up of the suspension unit at small piston loads, and high heat generation which can cause thermo-oxidation of the fluid and even energy losses. Ideally, with crop oils as ASAFs, zero or negligible level of mechanical friction is desired, in order to reduce heat generation that can breakdown the oil, resulting in arbitrary change of the shock absorber's designed damping parameters. This can be achieved through blending of the oil with the appropriate and potent boundary lubrication additives. Therefore, any of the tested VOs will need to be formulated with boundary lubrication additive(s), to meet the service duration required of ASAFs.

The curve in Figure 1 represents the average WSDs of the

worn surfaces of the balls after the wear tests, using the studied oils as lubricants. It can be seen from the curve that ATO have the highest wear rate, followed by GNO, and then CNO. COM recorded an exceptionally low WSD, representing a good fortification against wear which may be due to the presence of antiwear additive(s). These results supported the argument of [9] which characterized the performance of boundary lubricating oils by surface phenomenon, including their chemical and physical absorbed layers and film formation on the substrates through chemical reaction. ATO and GNO might have produced weaker film bonding on the rubbing surface which were easily washed out under series of rubbing cycles and increased surface energy as temperature increased.

There is a reversal in the order of performance by the studied oils in terms of wear rate, when placed against their friction reduction. In general, the crop oils though recorded better friction reduction than the mineral oil, manifestly produced higher wear in the test. The scenario in this study confirmed the concept that crop oils could bring down significantly friction coefficient at metal-to-metal contact zones, however this may not necessarily imply that they would lower the rate of wear in the same manner. This is because the reduction of friction is effected by coating of contacting faces with slippery layers, while reduction of wear is by formation of tough coatings on the surfaces [7], which most crop oils may not be able to sufficiently generate. One other reason friction reduction ability of VOs does not guaranty their equivalent reduction in wear rate is that the two functions are dependent on their respective molecular structure. ATO, probably by forming superior slippery coating at the contact zones of the balls, reduced friction forces beyond GNO, and the later beyond CNO, but the toughness of their absorbed film could not resist wear activities as did CNO.

As observed with most native base oils [10], the fatty acids of these three VOs may have an enhanced reaction level, such that they react with the metallic soap layer formed during their tribo-interactions with the metal ball faces, and chemically convert the soaps to form lower shear-resistant compounds. While the resulting compounds should be slippery layers which reduced friction forces, they however, turn to expose the boundary lubricated faces of the balls to aggravate wear, being easily removable from the boundary lubrication zone. This behaviour is worst with ATO, followed by GNO, before CNO, as revealed in this particular test (Figure 1).

Next on the list of reasons behind the poor wear protection of the VOs is that the polar functionality in the triacylglycerol molecules have weaker surface absorption energy, hence they are easily washed off the tribo-contact zones of the balls as load and heat tower [7]. This allows direct rubbing of asperities to asperities, resulting in increased wear. The trend of this weakness of the surface absorption energy goes downward from CNO to GNO, then to ATO. Relatively, the lower unsaturated fatty acids and polarity in CNO reduce its actions against metallic films, while its dominant saturated fatty acids generate intermolecular bonding which adhere strongly to metal surfaces, giving rise to the formation of compact, thicker and shear-resistant polymeric matrix layers on the surfaces that reduce the wear rate. From Figures 1, the wide varia-

tions of CoFs and WSDs of the studied oils are sufficient to discriminate between the oil samples. This justified the selected test conditions.

The morphologies of the worn ball surfaces under the boundary lubrication of the test oils, captured using an optical microscope (X500) are shown in Figure 3. A close observation of the captured worn surfaces of the balls lubricated by the three crop base oils (Figure 3(a), (b), and (c)) showed severe wear than by the reference commercial fluid (Figure 3(d)). It can be seen in Figure 3(a) that the wear on the surfaces of ATO-lubricated balls is quite severe. This is evidenced by noticeable slight overspreading of metal layers, plowed surfaces, and deep grooves that are even so broad in some parts. The overspreading of metal layers is traceable to plastic deformation at the tips of asperities caused by rubbing of surfaces due to insufficient boundary lubricant at the contact zone. Secondly, high deficiency of oil film at the loaded interfacial zones could cause bonding of asperity tips which result in shear within the material, as the bonded section become work hardened and very strong. The sheared material is transferred to the opposite surface giving rise to overspreading of metal at the surface. The plowed surface showed that sizeable particles have been removed from the surface. This must have occurred because of loss of oil film at the contact zones which allowed high build up of stresses there, resulting in local mechanical failure in which particles could coagulate and detach away as a single entity. This happens when environmental condition within the tribo-system reduces the surface energy to a level below the elastic energy at the contact areas, resulting in adhesive wear, which could be enhanced by cavitation and corrosion activities, and fatigue wear occasioned by repeated encounter of asperities. The implication of deep and furrows on the surfaces of the ATO-lubricated balls is that, apart from the insufficient surface protection by the oils, resulting in removal of particles at the interfacial zone owing to adhesive wear, the initially removed particles became very aggressive abrasive substances which created deep grooves on the worn surfaces. The reality of the wear mechanisms being adhesive (since the oil and the ball cup were initially free of any particles), followed by abrasion, made manifest by the presence of pronounced serially linear grooves, flowing in the direction of rubbing of the rotating ball against the stationary ones. The deeper and broader grooves or higher peaks of the ridges in some part of the surfaces suggest clearly that some of the detached materials or debris which contributed in plowing the surfaces were of significantly large sizes. The surfaces of the balls lubricated by CNO and GNO (Figure 3(b) and 3(c) respectively) have similar nature with that of the ATO lubricated ball. The variation is that CNO produced smoother and less deep furrows than GNO while the latter produced similar dept but smoother furrows than those of ATO. These indicate that CNO formed relative better surface protection film matrix, followed by GNO, then ATO. The surface of the ball lubricated by the commercial oil (Figure 3(d)) have quite shallow, few, and smoother grooves when compared to any of the VOs, attesting to a higher level of surface protection. From the stand point of wear protection, the three VOs will require the support of antiwear additive(s), to serve as ASAFs.

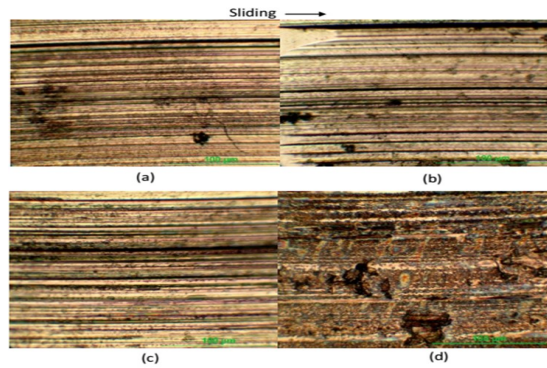

Figure 3. Morphology of the worn ball surfaces lubricated by the studied oils: (a) ATO; (b) CNO; (c) GNO; (d) COM.

Average surface roughness (Ra), averagely quantifies how the real worn surface at the end of the tribo-encounter has vertically deviated from the ideal surface before the encounter, hence, can be a suitable parameter for comparing lubricant performance. Table 1 shows the Ra values of one out of the three lower balls in the various tests performed using each of the studied oils.

Table 1: Worn ball Ra from each tested studied oil

	Oil Sample	Ave. surface roughness, Ra (μm)
1	ATO	0.287
2	CNO	0.032
3	GNO	0.382
4	COM	0.034

Among the vegetable oils, GNO shows the highest Ra, followed by ATO, and then CNO (Table 1), confirming in part the high degree of wear reported in Figure 1. This means that though the oil films of untreated ATO broke down easier than that of GNO, resulting in higher wear, smaller particle sizes were removed from the balls contact surfaces in ATO than in GNO. This can be deduced from the Ra values (Table 1) and the sizes of the grooves in the morphology in Figure 3(a) and (c). Oil films of CNO last longest and permitted removal of the smallest particle sizes among the base oils, as depicted by the Ra value in Table 1. One can deduce that the fatty acid chemistry of CNO, in collaboration with friction generated heat softens the removed particle, such that high contact pressures at the initially worn surfaces deformed them (particles) to the extent that their abrasive effects are minimized. The softening influence is lower with ATO. In GNO there appears to be heat-transformation hardening of the initial worn off particles resulting in creating deep grooves on the wearing surfaces of the balls by abrasive mechanism. COM, despite higher CoF than the VOs, still showed lower Ra. This indicates that Ra is more of the function of wear mechanism than of friction forces. The better wear prevention by the COM gives the lowest Ra. The Ra values of the VOs mean that they need to be treated with wear protection additives to meet the performance of the benchmark oil.

CONCLUSION

THIS work has demonstrated that Atili oil (ATO), coconut oil (CNO), and groundnut oil (GNO) have superior friction reduction capabilities compared to a commercial petrole-

um-based automotive shock absorber fluid (COM). This is purportedly due to the amphiphilic characteristics (owing to high polar nature) of the VOs which give them superior “oiliness”, and affinity to metal surfaces compared to the petroleum-derived oil. However, they have lower wear prevention abilities and created higher average surface roughness (Ra) compared to the commercial fluid. The VOs will require antiwear additive(s) to meet the performance of the commercial oil. With their (VOs) lower CoFs, they can appreciably reduce coulomb damping in automotive shock absorbers, especially when they are treated with friction modifier(s), giving room to dominantly viscous damping; thereby offering better ride quality, and lower heat generation.

ACKNOWLEDGMENT

The authors wish to thank the Faculty of Mechanical Engineering, Universiti Teknologi, Malaysia. This work was supported in part by grants from Research Management Centre (RMC) UTM, RUG (02G34, 02G35, 09H64), and Ministry of Education Malaysia FRGS (4F610).

REFERENCES

- [1] N. B. Kate and T. A. Jadhav, “Mathematical modeling of an automobile damper,” *Int. J. Eng. Res.*, vol. 2, no. 7, pp. 467–471, 2013.
- [2] D. L. Wright, “Shock absorber and similar mechanism.” US Patent 2,236,662, 01-Apr-1941.
- [3] D. Pirck and H.-D. Grasshoff, “Non-polluting shock absorber and level controller fluids.” US Patent 5,474,714, 12-Dec-1995.
- [4] J. C. Bart, E. Gucciardi, and S. Cavallaro, “Renewable feedstocks for lubricant production,” *Biolubricants Sci. Technol.*, pp. 121–248, 2013.
- [5] B. Bongfa, S. Syahrullail, M. K. Abdul Hamid, and P. M. Samin, “Suitable additives for vegetable oil-based automotive shock absorber fluids: an overview,” *Lubr. Sci.*, vol. 28, no. 6, pp. 381–404, 2016.
- [6] B. Bongfa, A. A. Peter, A. Barnabas, and M. O. Adeoti, “Comparison of lubricant properties of castor oil and commercial engine oil,” *J. Tribol.*, vol. 5, no. 1, pp. 1–11, 2015.
- [7] B. N. Rhodes, “Vegetable Oil Based Internal Combustion Engine Oil,” *Chem. Ind. YORK-MARCEL DEKKER-*, vol. 111, p. 557, 2006.
- [8] A. Adhvaryu, S. Z. Erhan, and J. M. Perez, “Tribological studies of thermally and chemically modified vegetable oils for use as environmentally friendly lubricants,” *Wear*, vol. 257, no. 3–4, pp. 359–367, 2004.
- [9] W. Castro, J. M. Perez, S. Z. Erhan, and F. Caputo, “A study of the oxidation and wear properties of vegetable oils: soybean oil without additives,” *J. Am. Oil Chem. Soc.*, vol. 83, no. 1, pp. 47–52, 2006.
- [10] L. I. Farfán-Cabrera, E. A. Gallardo-Hernández, M. Vite-Torres, and J. R. Laguna-Camacho, “Frictional Behavior of a Wet Clutch Using Blends of Automatic Transmission Fluid (ATF) and Biolubricant (Jatropha Oil) in a Pin-on-Disk Tester,” *Tribol. Trans.*, vol. 58, no. 5, pp. 941–946, 2015.

Coconut-Castor Oil Blend as Sustainable Basestock for IC Engine Oils: The Low-Temperature Fluidity

Binfa Bongfa^{1,2*}, S. Syahrullail², M.K. Abdul Hamid², P.M. Samin² and M. O. Adeoti³

¹School of Engineering, Federal Polytechnic Idah, 271101 Idah, Kogi State, Nigeria

²Faculty of Mechanical Engineering, Universiti Teknologi Malaysia, 81310 UTM Skudai, Johor, Malaysia

³Department of Mechanical Engineering, Federal Polytechnic Bida, 612101 Bida, Nigeria

*engrbinfabongfa@gmail.com

Abstract – This paper reports the depression of the pour point of coconut oil through binary mixture with castor oil, for lubricant in IC engines. The PP of the lead oil is reduced from 18°C to 12°C and further to 3°C by blending with 50%wt castor oil and treating the mixture with 8%wt of a Malaysian synthesized pour point depressant respectively. The pour point, studied using a pour point tester (ASTM D97-12 method), of the formulation presents it serviceable in the tropics as IC engine oil. The viscosity, and viscosity index, of the blended basestock are comparable to SAE 10W-30 oil.

Keyword – Binary mixture; castor oil; coconut oil; pour point; pour point depressants; IC engine oil

1 INTRODUCTION

CURRENT advances in engine oils requirements to meet; governmental emission regulations, fuel economy demands, and modern days improved engine tolerances [1] require better basestocks for formulation of engine oils. Vegetable oils (VOs) could be these better basestocks, because of their strong adherence to metal surfaces and thin-film formation, capable of lubricating very small intervening spaces. Moreover, modern trends in pursuit of energy independent and sustainable development identify vegetable oils as best options to sparse distributed, fast depleting petroleum deposit, and eco-impacting petroleum oils. vegetable oils as regenerative and cost-effective resources, non-toxic and excellent biodegradable compounds, couple to their attractive lubricant properties such as high viscosity indices, high flash points, excellent lubricity [2], good miscibility among others are desirable basestocks for machinery lubricating oils. However, vegetable oils are observed to be short of crankcase oil requirements, majorly due to insufficient tribological properties under severe loading, low thermo-oxidation resistance, hydrolytic instability, and poor lower temperatures activities [3]. The latest, traceable to the structures and arrangements of the fatty acids moieties, and waxy content of the oils, will cause poor tribological performance at low temperatures.

The poor low-temperature activities of vegetable oils occur at/or close to the flow limiting temperature of the oils, customarily called the pour point (PP). That is why PP, determined to a reasonable degree, characterizes the low-temperature properties of lubricants [4]. At this stage, the oil particles lack the kinetics to indicate any visible motion. Hence, the oil is said to solidify. This oil solidification is perceived to occur when high temperature soluble solid materials get crystallized, forming interlocking networks which trap and cease the flow of liquid oil [5].

One essential requirements of today's crankcase oils are upgraded cold weather starting, when the oils' lowest pump-able temperatures are as low as -35°C [1]. Unfortu-

nately, vegetable oil-based lubricants exhibit cloudiness, precipitation, loss of fluidity, high resistance to pumping, and even solidify at -15°C [6], due to the tendency of their 'bend' triglycerol backbones to uniformly stack together at low temperatures, and form microcrystalline structures [7].

Most desirable pour points for specific applications are obtained by blending the processed base stocks with pour point depressants (PPDs). PPDs lower the pour points of oils through the mechanism of physical interference in which they break down the molecular clusters of the oil to prevent nucleation, or decelerate wax crystal agglomeration by coating the wax molecules, or fit themselves into the structure of the wax crystals, thereby interrupt their growth [5]. Some achievements on depressing the pour points of native vegetable oils using PPDs have been reported [3], but there is scarcity of reports on remarkable success on the lauric oils, particularly coconut oil (CN) by this approach. pour point of native CN has been reduced from 24°C to 12°C [7], from 23°C to 13°C [8], and 20°C to 10°C [9], but with as high as 10 to 15% dose of additives. These are real achievements, but short of engine oils requirements, and cost-ineffective. One common line of thought is that vegetable oils, due to their non-uniform characteristics, could complement one another to meet lubricant requirements [10]. CN possesses high value (85 to 90%) of short-chain saturated fatty acids, giving it good friction and wear control [11]. Sadly, this also gives it high pour point and poor response to PPDs.

Castor oil (CT), a lower molecular weight oil, has cis bonds in the structure of it unsaturated ricinoleic-rich hydroxyl acid [12], giving it excellent low pour point (-33°C), good friction and wear control, but exceptionally high viscosity [6], and undesirably low viscosity index.

The nature of respective dominant fatty acids and the potential lubricant profiles of CN and CT take positions at either extremes, particularly the low temperature fluidity. This reasonably suggest that, a blend wedlock between the two oils could result in considerable depression of the pour point of CN to fit into lubricants base stock stand-

ards. However, mixing the two oils in several proportions yielded no impressive results [7]. 50:50 proportion by weight of CN to CT (Indian cultivars) only reduced the pour point of the former from 24°C to 21°C. Poor understanding of crystallization mechanisms of mixed triacylglycerols acids has made bleak the prospect of achieving desirable low-temperature characteristics through the blending of vegetable oils. This may only be established through several experiments [6]. The conclusion [7] that mixing CN with CT is not effective in reducing the pour point of CN is, somewhat too early, since the resultant mix was not treated with PPD(s). This argument by the authors of the present work is based on a reported work in which the influence of a 20% polyalphaolefin on pour points of several vegetable oils [13] was not so significant, until after additivation.

CT is anticipated to exhibit better response to PPD than CN, owing to its rich unsaturated fatty acid (ricinoic) which is of the oleic series. The postulation by the author of this current work is that the mixture of this two oils, if treated with PPD could reasonably lower the pour point. This is possible because the presence of CT molecules which are readily penetrable by copolymer chains can encourage easy co-crystallisation activities of PPDs. Several mixtures in different proportions of these two oils were made to achieve a viscosity at 100°C equivalent to SAE10W-30 engine oil, for IC engine use, considering other advantages. The resultant mix was treated with three different PPDs, separately and in several proportions, and the pour point tested in each case. The appropriate proportion of the PPD which offered the best performance in the selected mixture was tested on pure coconut oil and reported. This is to ascertain whether the blend with castor oil altered the response of coconut oil to PPD significantly as postulated. The pour point of an SAE 10W- 30 premium engine oil was also tested for benchmarking.

2 MATERIALS AND METHODS

THE materials used in this work include coconut oil and castor oil obtained from local producers in Nigeria. Three PPDs, branded HB-EX-PPD-A1 (proprietary blend), HB-EX-PPD-AS1 (oil-soluble acrylate polymer copolymerized with vinyl pyridine), and HB-EX-PPD-L1 (maleic anhydride-styrene polymer), and a commercial SAE10W-30 engine oil obtained from Malaysia.

Blends of CN to CT (wt/wt %) made to arrived at a suitable viscosity and VI for IC engine oil (SAE 10W-30) were: M20% = 80:20, M30% = 70:30, M40% = 60:40, M50% = 50:50, and M60% = 40:60, similar to proportions of bio base oil blends in other literatures [7, 10]. Kinematics viscosities of the oils were determined using rotary viscometer according to ASTM D445, and the VIs as per ASTM D2270 methods. Based on arguments from literatures [7, 14], sample M50% was blended with 0, 2, 4, 6, and 8%wt of each of the PPDs separately and the PP tested in each case using a pour point tester (ASTM D97-12 method) [6, 15].

3 RESULTS AND DISCUSSION

FROM the viscosities at 100°C of all the tested oils (Table

1), SAE viscosities rating will classify CN and M20% as SAE 20. M30%, M40%, M50%, M60%, and the commercial engine oil (CM) will be classified as SAE 30, while CT will fall under SAE 40. Apart from CT which has very low viscosity index, each of the studied candidate oils has multi-grade viscosity index. Increase of CT in the mixture, increase the viscosity at 40°C of the mixture, but reduces the VI. The viscosity at 100°C increased until CT reached 50 %wt, after which a reduction in this viscosity is noticed. The VI of M20%, M30%, M40% and M50% are higher than that of CM. This implies that they will have sufficient viscosities to provide adequate films between rubbing surfaces at high temperatures than the commercial engine oil.

Table 1: Kinematic viscosity/VI of the oils and their blends

	Oil	Specific gravity	Kinematics Viscosity (cSt)		VI
			at 40°C	at 100°C	
1	CT	0.960	243.57	16.23	56
2	CN	0.905	26.97	8.59	327
3	M20%	0.910	34.49	9.06	261
4	M30%	0.910	41.81	9.52	222
5	M40%	0.915	44.70	9.80	213
6	M50%	0.930	61.29	11.99	196
7	M60%	0.940	69.44	9.75	121
8	CM	0.860	51.98	9.43	167

Candidate oils M20%, M30% and M40% have reasonably lower viscosities at 40°C (Table 1) than the CM, implying better pumpability, hence better flow to tribo-contact zones at low temperatures. Candidate blends M50% and M60% have higher viscosities at low temperatures than the CM (Figure 1), implying poorer pumpability and higher losses to viscous friction at lower temperatures. However, the moderate tribo-film possibility by M50%, due to its closer viscosity range to CM will rather offer a preferred oil film thickness capable of reducing wear and friction.

At high temperatures, candidate blend M20% may have slightly lower film supply than CM, but candidates M30%, M40%, M50% and M60% will offer better tribo-films than the CM.

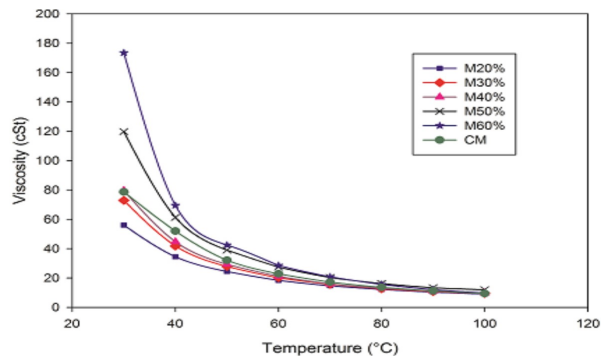

Figure 1. Viscosity-temperature plots of the mixed base oils and the commercial oil

3.1 Pour points of the experiment oils

A The pour point of the coconut oil sample in this experiment is measured to be 18°C, very close to the value (20°C) obtained in literature [9], but significantly differs from 23°C and 24°C [7, 8]. These variations may not be unconnected with the climate, soil and growing location of the oil plants, among other factors responsible for the non-uniform characteristics of vegetable oils, even those of the same cultivar. CT was used at varying proportion (20, 30, 40, 50, and 60% wts) to blend CN to see how the former can affect the pour point of the latter. 20 and 30 %wt of CT made no noticeable impact on the pour point of CN, but when diluted with 40 %wt of CT, the pour point of CN stepped down to 12°C (see Table 2). However, further diluents (at 50 %wt and 60 %wt of CT) could not make any improvement on the pour point again. This confirmed that diluents have limited effect on the pour points of vegetable oils [6]. The achieved lowest pour point by this mixture may without further treatment provide certain levels of lubrication in engines at relatively low temperatures, especially in the tropics. However, it is evident that the viscosity of the oil (mixture) at warm-up in these regions, will exhibit poor flow to intervening spaces, and greater frictional losses the conventional counterparts under the same conditions. These losses at warm-up can be so high, around 2.5 times above the frictional losses in sufficiently heated lubricants [16].

Table 2: Pour point of the studied oils

	Oil Sample	Pour point (°C)
1	CT	-18
2	CN	18
3	M20%	18
4	M30%	18
5	M40%	12
6	M50%	12
7	M60%	12
8	CM	<-30

It is not so certain how CT molecules affect the molecules and/or wax content of CN in lowering the PP. However, one can suppose that there is a co-nucleation of the CT molecules with those of the lead oil which modifies the original crystallisation matrix of the latter, as temperature lowers, such that the composite matrix delays crystal growth and may not allow early fusion of nucleated crystals that will cause solidification or hinder fluidity at the original solidification temperature of CN. Notwithstanding, at lower temperatures, a limit may be reached where the differing of solidification by the influential molecules (CT) is not possible as the bonding of the lead oil molecules gets stronger with falling temperature. Possibly, 40, 50, and 60 %wt of CT in CN formed a plateau zone (from the PP values in Table 2) after which the PP of the blended oils may fall. But the resultant viscosities (at 40°C) and viscosity indices of mixtures having higher proportions of CT may not be suitable for the intended application, since the two parameters (of the mixtures) are noted to increase and decrease respectively with rising proportion of the CT.

3.3 Response of the selected blended base oil to PPDs

M50% was selected and treated with varying proportions of PPDs to prove the postulation of the authors of this work, and to argue and/or concomitantly put up a course on the 'brickwork' laid by Ajithkumar [7]. Although the responses of M50% to PPDs failed to meet the minimum standard requirement for pour point of lubricants (Figure 2), one of them still ensures safe pour point within low temperature working limits in the tropical regions. Impressively, at 8 %wt of HB-EX-PPD-A1, the PP of the said oil was depressed to 3°C. This PPD is likely to be of the linear alkyl side-chain type, having varying length structure with most of the chain lengths closely matching that of hydrocarbon chains in the mixed base oil, giving it an optimum performance.

To verify the contribution of CT to the response of CN to the PPDs, the very proportion (8 %wt) of the best performing PPD (HB-EX-PPD-A1) in M50% was tested on pure CN. The result (Figure 2) showed that mixing CN with the CT has contributed immensely to the response of the former to the PPD. The presence of the ricinoleic fatty acid from the CT in the mixed oil (M50%) may have engineered the favourable response of CN to the said PPD. This by far justifies the postulation by the authors of the present work: that the mixture of CN with CT may not show immediate significant effect on the low-temperature fluidity of CN, but may provide a good playground for PPDs.

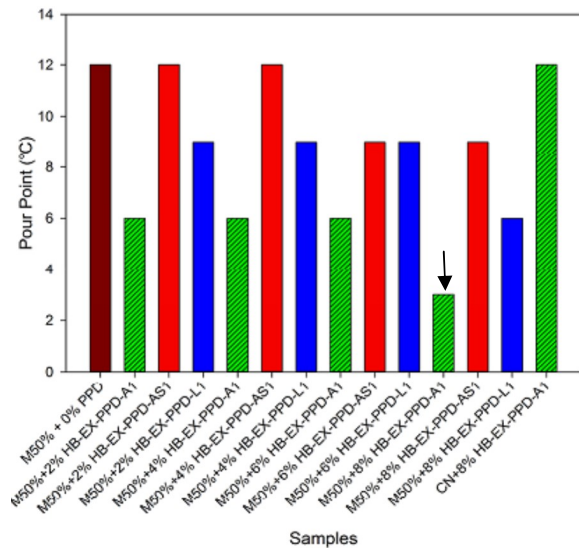

Figure 2. Effects of PPDs on coconut-castor oil (50:50 wt/wt) mixture, and on pure coconut oil

It is noticeable from the response of pure CN to 8 %wt blend of HB-EX-PPD-A1 that the presence of ricinoleic molecules of CT in blend M50% might have suppressed the resistance of the dominant lauric acids in CN against PPD. This may be achieved by making soft the clustering molecules of the composite oil for the PPD to break and defer nucleation, or creating more penetrable allowances for the inclusion of molecules of PPD into the propagating crystals, to envelop the small nucleated crystals and or co-crystallizing with them (the nucleated crystals) at slower rate. By these, the PPD may be able to postpone early crystallization of the M50% at higher temperatures than what had happened in pure CN. Moreover, the ricinoleic acid

molecules might have brought a balance between the saturated and the unsaturated fatty acids in the mixed base oil, giving it an equivalent low-temperature characteristic suitable for the activities of PPDs.

The effect of HB-EX-PPD-A1 on the mixed base oils have not yet indicated pour point reversal. Higher proportion of HB-EX-PPD-A1 may further reduce the pour point of this mixture. However, due to economic and technical reasons, a higher proportion is not advisable. The mixed vegetable oils are in crude form, implying high waxy fluid, therefore, the performance of HB-EX-PPD-A1 point to the fact that it has high wax interaction factor (i.e. high strength of interaction or waxy side-chains).

2 and 4%wt of HB-EX-PPD-AS1 in the mixed candidate oil (M50%) produced no effect on its (oil) pour point. At 6 %wt addition, the pour point of the oil was reduced by 3°C to 9°C. Further increase of the dose made no improvement on this property. This means that the spatial stabilisation of the PPD against the crystals of the base oil became insufficient. Hence, the wax crystals built up sufficient structure(s) that halted the mobility of the oil molecules. Additional %wt of the PPD may only add extra wax to the oil molecule network leading to PPD reversal.

2%wt of HB-EX-PPD-L1 reduced the pour point of the oil to 9°C, but no reduction was recorded until at 8 %wt of the pour point. This remarkable response at 8 %wt concentration means that the base oil wax particles were responsible for non-reduction at the intermediate %wt.

CONCLUSION

ONE-TO-ONE mix ratio of coconut oil to castor oil produced adequate viscosity, equivalent to SAE 10W-30 engine oil, and with even higher viscosity index. This also lowered the pour point of the coconut oil, and more importantly, prepared a better base for pour point depressants to have reasonable impacts on the pour point of coconut oil. Employing a proprietary pour point depressant, branded HP-EX-PPD-A1, at 8 %wt in the said binary mix of the oils lowered the pour point to as low as 3°C. This result gives assurance that the treated oil can flow to the various tribological contacts (intervening spaces) of IC engine assembly at all practical temperatures conceivable in the tropical region.

ACKNOWLEDGMENT

The authors wish to thank the Faculty of Mechanical Engineering, and Faculty of Petroleum Engineering, Universiti Teknologi, Malaysia. This work was supported in part by grants from Research Management Centre (RMC) Universiti Teknologi, Malaysia, RUG (02G34, 02G35, 09H64), and Ministry of Education Malaysia FRGS (4F610).

REFERENCES

[1] S. C. Lakes, "Automotive Crankcase Oils," *Synthetics, mineral oils, and bio-based lubricants: chemistry and technology*, L. R. Rudnick, ed., pp. 421-432, Boca Raton FL: CRC press, 2013.

[2] B. Bongfa, S. Syahrullail, M. K. A. Hamid, and P. M. Samin, "Suitable additives for vegetable oil-based automotive shock absorber fluids: an overview," no. March, pp. 381-404, 2016.

[3] L. A. Quinchia, M. A. Delgado, J. M. Franco, H. A. Spikes, and C. Gallegos, "Low-temperature flow behaviour of vegetable oil-based lubricants," *Industrial Crops and Products*, vol. 37, no. 1, pp. 383-388, 5//, 2012.

[4] S. Z. Erhan, and S. Asadauskas, "Lubricant basestocks from vegetable oils," *Industrial crops and products*, vol. 11, no. 2, pp. 277-282, 2000.

[5] S. P. Srivastava, *Advances in lubricant additives and tribology*: Tech Books International, 2009.

[6] S. Asadauskas, and S. Z. Erhan, "Depression of pour points of vegetable oils by blending with diluents used for biodegradable lubricants," *Journal of the American Oil Chemists' Society*, vol. 76, no. 3, pp. 313-316, 1999.

[7] G. Ajithkumar, N. Jayadas, and M. Bhasi, "Analysis of the pour point of coconut oil as a lubricant base stock using differential scanning calorimetry," *Lubrication Science*, vol. 21, no. 1, pp. 13-26, 2009.

[8] N. H. Jayadas, and K. P. Nair, "Coconut oil as base oil for industrial lubricants—evaluation and modification of thermal, oxidative and low temperature properties," *Tribology International*, vol. 39, no. 9, pp. 873-878, 9//, 2006.

[9] D. Abeyundara, C. Weerakoon, J. Lucas, K. Gunatunga, and K. Obadage, "Coconut oil as an alternative to transformer oil." pp. 1-11.

[10] L. Quinchia, M. Delgado, C. Valencia, J. Franco, and C. Gallegos, "Viscosity modification of different vegetable oils with EVA copolymer for lubricant applications," *Industrial Crops and Products*, vol. 32, no. 3, pp. 607-612, 2010.

[11] I. Golshokouh, S. Syahrullail, F. Ani, and H. Masjuki, "Investigation of Palm Fatty Acid Distillate as an Alternative Lubricant of Petrochemical Based Lubricants, Tested at Various Speeds." p. 72.

[12] H. Mutlu, and M. A. Meier, "Castor oil as a renewable resource for the chemical industry," *European Journal of Lipid Science and Technology*, vol. 112, no. 1, pp. 10-30, 2010.

[13] S. Z. Erhan, B. K. Sharma, and J. M. Perez, "Oxidation and low temperature stability of vegetable oil-based lubricants," *Industrial Crops and Products*, vol. 24, no. 3, pp. 292-299, 2006.

[14] J. C. J. Bart, E. Gucciardi, and S. Cavallaro, "7 - Formulating lubricating oils," *Biolubricants*, J. C. J. Bart, E. Gucciardi and S. Cavallaro, eds., pp. 351-395: Woodhead Publishing, 2013.

-
- [15] ASTM-D97-12, "ASTM D97 Standard Test Method for Pour Point of Petroleum Products," ASTM International, 2012, p. 5.
- [16] A. Roberts, R. Brooks, and P. Shipway, "Internal combustion engine cold-start efficiency: A review of the problem, causes and potential solutions," *Energy Conversion and Management*, vol. 82, pp. 327-350, 2014.

Toward Green Road Freight Transportation Trends: Truck Platoon Application

S. Moh Ahmed^{1,2*}, Said. Hayat¹, Yassin El Hillali², Atika Rivenq²

¹ IFSTTAR, Villeneuve d'Ascq Cedex, France

² UVHC, IEMN-DOAE Valenciennes, France

*nomsaidahmed@gmail.com

Abstract – The place of freight transportation cannot be underestimated or disregarded in the growth of the economy as it's fast rising to a world market. A large part of the inland freight transport is evident in its use on roads. It is dynamic and relative to change as it can be subjected to changes due to the un-ending innovations of man over the coming years, as cognizance needs to the recent trends of initiatives and innovations which have led to the improvement of our technological world. The application of truck platoon in freight transportation has occasioned an introduction of integrated goods freight transportation which has optimized logistics and real-time updates about our vehicular traffic communication, collaborative driving, and autonomous vehicles. In this research work, we gave an insight into the problems in making a reality, a better and adequate movement of goods by the road system to reduce environmental issues and how we can proffer solutions with the aid of technology. We emphatically explained a medium which can increase the effectiveness of this movement scheme by truck platoon transports in order to fulfill the task on a prescribed road network..

Keyword – Logistics; Truck Platoon; v2v, v2i Technology

2 INTRODUCTION

TRANSPORTATION is one of the key logistic functions that combine separate types of production procedures, from manufacturing to delivering products to consumers. Optimization of transport can largely determine the efficacy of the entire logistic system; the demand for mobile service is fast growing and closely related to the economic growth [1]. The movement scheme assists the general transport of people and goods. However, the mobility aspect is also accountable for the larger percentage of worlds energy & emission due to rise in the technical knowledge & global nation, then transport needs not to be underestimated in the production sector. There is, however, a quest for developing a more sustainable fuel for the transportation sector. A fast-growing improvement in technology has prompted the production of automatic vehicles with less use of fuel, cruise control and joint driving ability. We are in 21st century as a result of major technological advancement in the environment [2]. We are in an era where major advances would be introduced into the market and society over the next couple of decades. For example, vehicular communications [3, 5] enable a large set of new applications, such as collision warning and avoidance [3], automated intersections, and vehicle platooning [4,6]. Vehicular position and velocity data are readily available today [5]. For freight transportation, such data can be combined with advanced vehicle models to make decisions on fuel-optimal routes. Transport systems spanning over large geographic areas with real-time data gathering is been used for increasing efficiency and flexibility in the planning of transport assignments [7], the development of a new freight transport system architecture based on these emerging technologies poses several obstacles. One challenge is simply the overall scale of the system: in the EU there are about 2 million heavy trucks [8]. Recently, the Green transportation and sustainable freight

transportation are increasingly important issues in view of rising fuel costs and environmental concerns. Although all forms of transportation contribute to greenhouse gases and congestion, trucking has the largest impact. Truck platoon technologies can be optimized for green road freight transportation to reduce environmental hazard without affecting the maximum output of the trucks.



Fig1: trucks platooning

2 ENVIRONMENTAL CONCERNS

The largest source of air pollution in this world is Transportation. Pollution caused by trucks and car are responsible for immediate and long-term effects on the environment, Exhausts from car emit a large percentage of gases and solid matter which are responsible for acid rain, global warming and environmental / human health hazards. Also, Fuel spills and noise generated by Engine causes pollution. Cars, trucks and other forms of transportation are the largest contributor to air pollution in the United States, but car owners can reduce their vehicle's effects on the environment [9]



Fig2: Road freight emissions [10]

2.1 The impact of Road Freight Transport on the Environment

According to studies, road freight transport causes 57% of worldwide carbon dioxide (CO₂) emissions, while additional levels come from warehousing and handling. In 1995, 22% of CO₂ emissions came from the energy use (fossil energy sources) in the transport sector [37]. Road freight grew rapidly during the second half of the twentieth century, because the transport policy in many countries focused predominantly on low-cost, short and prompt ways of delivering goods, especially food. Vehicles, even if more polluting, were considered as economical and faster modes of transport than trains (Jaroszowski, 2012). Transport, just like the growing demand for electricity, has impacted the total increase in global gas emissions

in OECD countries. During the last 30 years, gas emissions have been noticed to rise more or less 1.7% per year. The average consumption of electric power and private cars in Australia, for example, accounts for about 20% of gas emissions, whereas 80% is connected with public and business services or consumer goods supply. Not only is the carbon dioxide emission is a worldwide problem in transportation. In 1996 the National Greenhouse Gas Inventory Committee published the results of non-CO₂ emissions in the road sector, where it was clearly shown that medium and heavy trucks used in freight transport also produced great amounts of harmful gases such as: CH₄, N₂O, NO_x and CO (Lenzen, Dey, Hamilton 2008). (Table 1).

Table1: Truck emissions: the constituents of air pollution and their impacts [11].

Constituents of air pollution	Impacts
Particulate matter (PM)	These particles of soot and metals give smog its mucky appearance. Fine particles (less than one-tenth the diameter of a human hair) pose more serious threat to human health, as they can penetrate deep into lungs. PM is a direct (primary) and indirect pollution from hydrocarbons, nitrogen oxides, and sulfur dioxides. Diesel exhaust contributes to PM pollution.
Hydrocarbons (HC)	These pollutants react with nitrogen oxides in the presence of sunlight to form ground-level ozone, a primary ingredient in smog. Though beneficial in the upper atmosphere, at the ground-level this gas irritates the respiratory system, causing coughing, choking, and reduced lung capacity.
Nitrogen oxides (NO _x)	These pollutants cause lung irritation and weaken the body system defences against respiratory infections such as pneumonia and influenza. Furthermore, they assist in the formation of lower-level ozone and particulate matter.
Carbon monoxide (CO)	This odourless, colourless, and poisonous gas is caused by the combustion of fossil fuels such as gasoline and is emitted primarily from cars and trucks. When inhaled, CO blocks oxygen from the brain, heart, and other vital organs. Fetuses, newborn children, and people with chronic illnesses are especially susceptible to the effects of CO.
Sulfur dioxide (SO ₂)	Power plants and motor vehicles create this pollutant by burning sulfur-containing fuels, especially diesel. Sulfur dioxide can react in the atmosphere to form fine particles and poses great health risk to young children and asthmatics.
Hazardous air pollutants (toxics)	These chemical compounds are linked to defects at birth, cancer, and other serious illnesses. The Environmental Protection Agency estimates that the air pollutants emitted from cars and trucks ; which include Benzene, acetaldehyde, and 1,3-butadiene – account for half of all cancers caused by air pollution.
Greenhouse gases	Motor vehicles also emit pollutants, such as carbon dioxide, that contribute to global climate change. In fact, cars and trucks account for over one-fifth of the United States' total global warming pollution; transportation, which includes freight, trains, and air flight, accounts for around thirty percent of all heat-trapping gas emissions.

3 GREEN FREIGHT TRANSPORT

Freight movement is responsible for 16% of all corporate greenhouse gas emissions thereby qualifies it as one of the largest contributors to carbon footprint. The emissions is gotten directly from trucks, trains, ships and planes which carry goods. Companies have the power and financial incentive to minimized their environmental impact from freight. By employing smarter logistics strategies, they can operate more efficiently and affordably [12, 20].

4 CONCEPTUAL DEFINITION OF TRUCK PLATOONING

Truck platooning refers to automatic driving of trucks in small convoys, a short distance apart, resulting in smooth traffic flow, with higher traffic safety, fuel savings and a reduction in CO₂ emissions. [12] Truck platooning involves carrying out the automatic control of Truck convoys on highways. A truck in the platoon can be in one of three cases: leader mode, follower mode and free mode; free mode represents the free case where the Truck does not join to any platoon. The leader mode and the free mode are manual control, while the follower control mode is completely automatic. Each transition between these

modes is one of the principal platoon supervision operations. These operations are: creating a new platoon, merging two platoons, and the truck input/output procedures are from a platoon. The follower is operated by both control systems (i.e. longitudinal and lateral control systems). A multiple-sensor system is used to provide vehicles velocity, acceleration and localization of vehicle, and also the inter-trucks spacing in the platoon. [19]. The triple measurement device is used for determining the inter-truck spacing signal: multi sensor representing as laser range-finder, a camera which is embedded and an observer, on the basis of the system dynamic equations. This redundancy makes it possible to perform sensors fault detection and identification. Furthermore, it can be exploited to increase the reliability of the follower control mode by introducing a global PS architecture that includes a data fusion level and a decision-making system. The free mode represents the case where the truck does not belong to any platoon.

5 TECHNOLOGIES FOR TRUCK PLATOONING

An overview, from local to global level technologies that enable truck platooning is shown in Figure 2. On local level, technologies within a small range of the vehicle are effective, such as Cruise Control (CC) and Adaptive Cruise Control (ACC). The ACC system is an extension on the CC system and has been illustrated as a means to enable vehicle platooning [26]. Cruise Control is a system which takes over the throttle of the vehicle to maintain a steady speed as set by the driver. The throttle valve controls the power and speed of the engine by limiting the amount of air intakes and is actuated automatically, instead of by pressing a pedal, when the cruise control system is engaged [29]. The Adaptive Cruise Control system is an extension on the CC system, which automatically adjusts the vehicle speed to maintain a safe distance from vehicles ahead. ACC uses either radar or laser sensors to detect the speed of and distance to the vehicle ahead. If the distance to a vehicle or object ahead diminishes, the system will send a signal to the engine or braking system to decelerate the vehicle and the other way around for increasing distance [29].

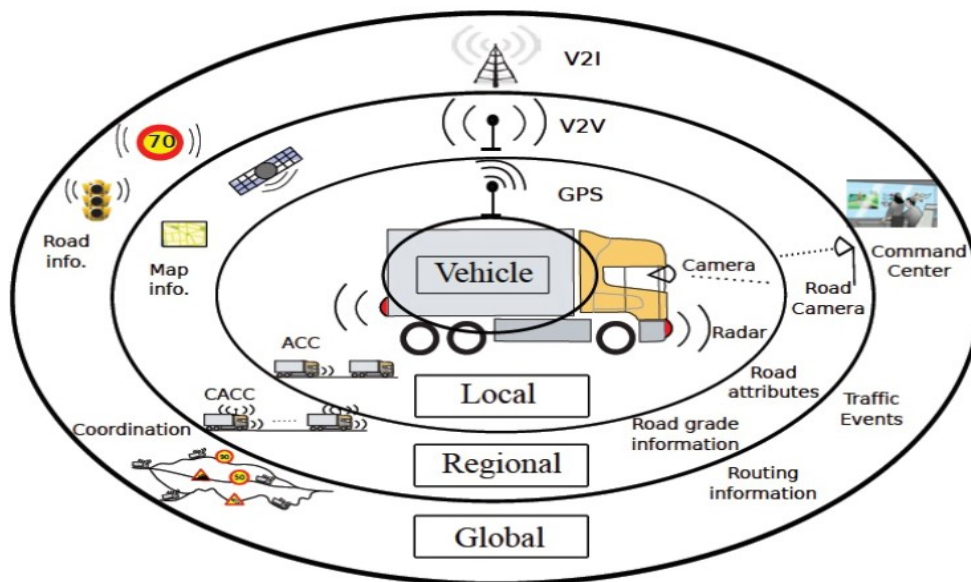

Fig3: Technologies for truck platooning [21].

An extension on the ACC system is Cooperative ACC (CACC), which uses longitudinal auto- mated vehicle control by accounting for road information, such as road grade, and traffic events occurring further ahead in the platoon, such as traffic congestion. This is obtained by wireless communication in short and wide range relative to the vehicle, i.e. by Vehicle to Vehicle (V2V) communication and Vehicle to Infrastructure (V2I) technology, respectively [35] [32]. The interaction between vehicles is enabled through V2V communication and can therefore improve safety. By combining Global Positioning Systems (GPS) and V2V technology, the relative position estimates of neighboring vehicles can be made with high accuracy. Hence, smoother control can be implemented through prediction based upon the gathered information, enabling

cooperative driving and realizing automated vehicle platoons [30] . On global level, implementation of routing and road information is enabled through V2I technology. A command center or fleet manager can monitor the vehicles in real-time traffic through V2I, enabling the possibility to react upon road and traffic information and optimize the transport mission and thereby the vehicle’s fuel consumption. For example, fuel consumption can be decreased by adjusting the vehicle speed in order to form a platoon. Furthermore, an alternative path can be found through V2I to ensure the arrival deadline of the transport mission when obstructing traffic situations are encountered [33] [18]. Technologies such as V2V and V2I are part of Intelligent Transport Systems and services (ITS), where ITS denotes the integration of Information and Communication Tech-

nology (ICT) with transport infrastructure, vehicles and users [21]. Figure 3 represents an illustration of ITS, where ITS includes all types of communication in and between vehicles (V2V communication) along with communication between vehicles and infrastructure (V2I communication). With the aid of these communication devices, a cooperative system is formed for supporting and replacing human functions in various driving processes in order to enhance operational performance, mobility, environmental benefits, and safety. [21].

6 EFFECTIVE TRUCK PLATOONING

Platooning is found to contribute towards energy saving in the following aspects:

First is the reduction of aerodynamic drag while the second is the provision of larger room due to increased road capacity to surrounding traffic. The first is microscopic contribution, while the latter is macroscopic contribution. Microscopic contribution involves conducting the simulation of computational fluid dynamic with the aims of investigating the aerodynamic drag reduction [12]. The CD-value of the front truck and the last truck decreases above 20 %, and that of the middle truck decreases by about 50 %. This implies that when 3 trucks are driving with a small gap then the aerodynamic drag decreases,

and this contributes to energy saving. Therefore, when trucks are driving at high speed, the aerodynamic drag is larger than the rolling resistance; there would be decrease in the fuel consumption of the platoon by about 15 %.

6.1 Platoon truck Energy Consumption

According to the Energy ITS project; since 1990, while the energy consumption trend in the industry sector has been almost constant, those in the civil sector and transportation sector have increased. In the transportation sector it has increased by 7 % in 2010 as compared to that of 1990. In 2010, the energy consumption by automobiles accounts for 89 % for passenger transportation and for 90 % for freight transportation, while the transportation volume (passengers-km or ton-km) by automobiles accounts for 65 % for passengers and 61 % for freight transportation. The fuel consumption was measured during the experiments on a test track under the conditions that the velocity was constant and 80 km/h, the gap was 10m and 4.7m, and the trucks were empty-loaded. Figure 1 shows the results. The measurements indicate 13% energy saving at 10m gap and 18 % saving at 4.7m gap. When the trucks are ordinarily loaded and drive at 80 km/h, the fuel saving will be 8 % when 10 m gap of 10 m, and 15 % when 4 m gap. [22]

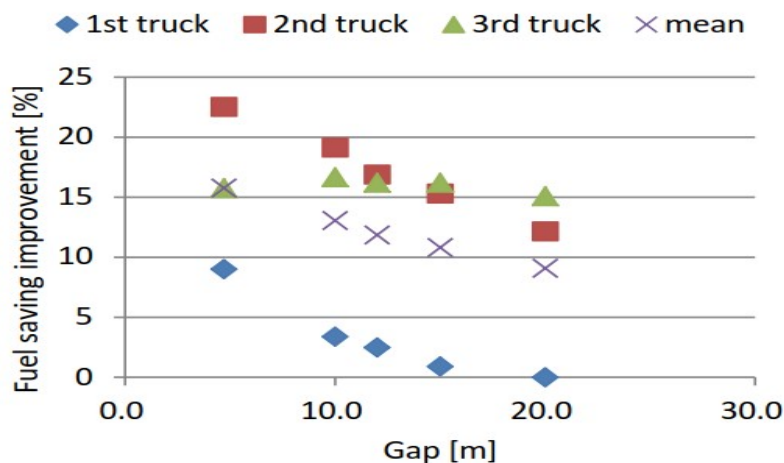

Fig 4: Relationship between the fuel saving improvement and the gap in the platoon [22].

6.2 Platoon truck Emission

The CO₂ emission trend in Japan and in general, the increasing rate of the CO₂ emission from the transportation sector is larger than that from whole Japan. Like the energy consumption trend, due to unfavorable economy, the increasing rates have been decreasing recently, and in summary the increments rate of the sector is 8.6 %. In 2008 compared to that in 1990, and that of Japan is 6.2 %. The CO₂ emission from the transportation sector (228 M ton in 2008) accounts for 19 % of the total emission from Japan (1,214 M ton in 2008), and 90 % of CO₂ of the transportation sector is released from automobiles. Thus, automobiles are major causes of the global warming, and since the energy of current automobiles that use an internal combustion engine is petroleum that emits CO₂ after burning, the counter-measure of the global warming for automo-

biles(current) is energy saving.

7.2 TRUCK PLATOONING PROJECTS IN THE WORLDWIDE

The acknowledgement section should come at the end of the manuscript before the reference section. Sponsorship and financial support acknowledgments should be included in the acknowledgment section. Financial support should be acknowledged in the following manner: This work was supported in part by ABC under Grant EFG1234.

Individuals who contributed in other ways to the work or who rendered some form of assistance to the article should also be acknowledged here.

7.3 State of the Art

In the last few decades, several platooning projects have started to explore different aspects of platooning. These projects defined platooning objects, platoon properties, and platoon operations as per their own notion.

1. **SARTRE** - In a European platooning project SARTRE, a vehicle is defined as following vehicle, lead vehicle, other vehicle, potential following vehicle, potential lead vehicle, potential platoon vehicle, or platoon vehicle. Different platoon operations such as create platoon, join platoon, maintain platoon, leave platoon, and dissolve platoon are defined as platoon use cases (Bergenheim et al., 2010; Robinson et al., 2010).
2. **PATH** - The US based truck platooning project PATH only referred to two types of platoon objects as ; lead vehicle and preceding vehicle and platoon properties such as inter-vehicle spacing, inter-platoon spacing, platooning vehicle types, number of vehicles in platoon, platoon length, vehicle acceleration or deceleration, communication time lag and delay, and highway operating speed (Carbaugh et al., 1998; Michael et al., 1998; Rajamani et al., 2000). Operations like lane keeping, lane change, join, and split are tested in this project.
3. **SCANIA** - The Swedish truck maker SCANIA has started two platooning projects: Distributed Control of a Heavy Duty Vehicle Platoon, and iQFleet (Bergenheim et al., 2012b). Here, Deng (2016) modeled a platoon class as a group of heavy duty vehicles with platooning capability and having three mandatory properties: platoonID, speed and a list of platoon members. Deng classified the driving behavior of a platoon into basic and advance operations. Basic operations include acceleration, deceleration and desired inter-vehicle distance adjustment. In contrast, speed planning and platoon aggregation and disaggregation are considered advance operations.
4. **Others** - In the Japanese platooning project Energy ITS, Tsugawa et al. (2011) defined the control system for path following and lane keeping operations. CHAUFFEUR3 demonstrated different maneuvers - coupling, termed as 'flthe joint', decoupling, termed as 'inverted fljoin joint', and platooning driving such as lane changing, accelerating and braking. Vehicles used in a platooning project COMPANION are not necessarily bound to the same source and destination: platoons can be formed on the flu by merging vehicles and other platoons, traveling jointly for parts of the route. To encourage development, integration and deployment of cooperative driving, the Grand Cooperative Driving Challenge were organized in 2011 and 2016. In terms of platoon operations, the challenge mainly tested collaborative vehicle movement as a platoon based on predetermined technology and interoperable communication standards and tested a join operation and allowed the change of role of participating vehicles (Lidström et al., 2011; Bergenheim et al., 2012b). Other than the above mentioned platooning projects, Amoozadeh et al. (2015) presented a platoon management protocol and simulated three basic platoon maneuvers: merge, split, and lane change. They also explained three platooning scenarios: leaving of

the leader, leaving of a follower, and entry at the end. The platoon management protocol considered first different variables that any platoon enabled vehicle should have, namely vehicle ID, platoon ID, platoon depth, platoon size and platoon members. Though different research projects and research articles discussed some of the platoon maneuvers and platoon properties, none of them defined those operations formally. More prominently, the different projects defined platooning objects and platoon operations in incompatible ways. For example, the join operation in SARTRE is the same as the aggregation operation in SCANIA's projects, and the coupling operation in CHAUFFEUR. Not only do terminology differ, but also the object and operation concepts. SARTRE used eight different platooning objects to address different platoon operations whereas most of the other projects used three objects: platoon leader, platoon follower, and platoon, and sometimes additionally free vehicle. SCANIA's projects defined the platoon creation and the platoon join separately, whereas other projects did not address platoon creation or considered create as an implicit operation of join. Moreover, typically no justification and explanation have been provided on the operation categorizations. Therefore, the requirement of standardization of platooning objects and operation is necessary. [17]

8. TRENDS OF TRUCK PLATOONING

Truck platooning has a number of impacts on transport system and environmental system.

8.1 Transport System

These impacts include; increased road capacity

8.1.1 Increase of Road Capacity

The major aim of vehicle platooning is to increase road capacity. In order to achieve this, it is important to operate vehicles closer together than its possible with manual driving. Unfortunately, a vehicle platoon system has never been deployed on a large scale. Most of the capacity studies are hence based on simulations.

One of the studies conducted by Vander (Werf, et al., 2015) focused on the capacity impacts of an increasing market penetration of ACC and CACC vehicles, relative to manual driving [15]. They performed a microscopic simulation of a 16-kilometer one-lane highway with on- and off-ramps every 1.6-kilometer. Initially, an analysis of simulation scenarios was conducted with vehicle type compositions of 100% manual driving, 100% ACC vehicles (time gap of 1.4 seconds) and 100% CACC vehicles (time gap of 0.5 seconds). These simulations resulted in a nominal capacity of respectively 2100, 2150 and 4250 vehicles per lane per hour. Later, they analyzed a scenario with a more realistic mix of vehicles. As it turns out, both ACC and CACC improve the highway capacity in all cases. [16]. However, the impact of ACC is relatively small: a capacity increase of at most 7% was achieved compared to manual driving. It is argued that ACC achieves this benefit by smoothing the traffic flow instead of closing the operating gaps. In fact, the 1.4 seconds time gap turned out to be modest compared to an average time gap of 1.1 seconds under

manual control. The analysis shows besides that CACC has the potential to significantly increase the capacity, especially for high market penetrations. This effect is explained by the need of a CACC system to have a preceding vehicle, which is also equipped with a CACC system. After all, a preceding vehicle needs to transmit information for following vehicles to operate. If a preceding vehicle is not equipped, the system behaves like ACC and acts solely on radar information. Similar results in terms of road capacity increase have been shown in AHS studies. One of them is a numerical analysis by Michael, et al., [13]. Their main conclusion is that AHS can increase the road capacity but the increase is dependent, among others, on:

- a. the degree of inter-vehicle cooperation
- b. average platoon length,
- c. the intra-platoon spacing.

Unfortunately, most studies about the impacts of platooning systems on the road capacity are based on simulation or analytical analysis. Better would be to measure the impacts of a particular platooning system in a large-scale test-bed. However, this is capital intensive and requires a good motivation in order to do so.

8.2 Environmental Issues.

8.2.1 Reduction of Environmental Impacts

The transportation system is a large contributor to the emission of green- house gasses. Indeed, transportation can have accounted for approximately 30% of the total CO₂ emission in the USA over 2008 [29]. Since environmental issues are a hot topic, the transportation industry is also looking for solutions to reduce fuel consumption and hence reduce environmental impacts.

Truck Platooning can be one of the solutions to environmental issues like global warming. Closely operating vehicles in a platoon reduce the average air resistance and hence the fuel consumption. This result was obtained in wind tunnel tests and field experiments [32, 18]. The results of the field experiments show that fuel savings in vehicle platoons are strongly correlated to the position of the vehicle in the platoon and operating distance. A vehicle operating with a vehicle in front and back, can save fuel up to 10% (operating distance of 3 to 6 meters). The last and the leading vehicle of a platoon experience savings of respectively 7% and 3-4%. Hence, all vehicles in a platoon benefit.

9. THE FUTURE OF TRUCK PLATOONING

There are some important infrastructure barriers that must be overcome to make truck platoon a realistic and effective concept for the nearest future. Present research studies focus more on lighter trucks instead of heavy trucks. By using heavy vehicles to study platoon, it provides more useful information about the effectiveness of truck platooning on green road freight transportation. Fuel consumption from a vehicle engine occurs as the vehicle travels on the green road with the output of the fuel contributing to Aerodynamic losses, Auxiliary loads and inertial grade. Truck platooning has a number of benefits. These benefits range from an increased road capacity and improved safety to a reduction of the environmental impacts

and improved driving comfort. Understanding these benefits and the impact of Vehicle Platooning is very important; they serve as the justification of the development of vehicle platoon systems. The automated truck platoon developed in the project consists mainly of N heavier (25 ton) trucks, and currently drives at 80 km/h with the gap of 10 m on a test truck and along an expressway before public use. [35]. The functions of the platoon are lane keeping, speed control, collision avoidance, and gap keeping. Among these functions, the gap keeping function contributes to energy saving, and the last one contributes towards increasing the safety and reducing the workload of drivers. The configuration of a truck for the automated platoon. The feature of the platoon system is high reliability with redundancy in the sensing systems, the vehicle control ECU (electronic control unit), the communication system, and the actuators. The control period for the trucks is 0.5-1.5s.

In (2020), an automated platoon of 3 trucks with automated lateral control will be introduced under mixed traffic. The gap will be 10 m at an early stage and will be shortened to 4 m afterwards. In the platoon CACC (Cooperative ACC) will be performed with the V2V communications to make traffic flow smooth. A driver will be in each truck. The energy saving goal is 8 to 15 % reduction by aerodynamic reduction and 5 % reduction by smooth traffic flow.

In (2030), a fully automated platoon of 3 or 4 trucks will be operated along a dedicated lane on an expressway, and a driver will be only on the lead truck. The energy saving goal is 18 % reduction by aerodynamic drag and 10 % reduction by eco driving. The length of a platoon is bounded, because a long platoon can disturb other traffic along an expressway, and the longest platoon is a 4-truck platoon in this project. [33].

CONCLUSION

This paper has reviewed platoon trucks technology, by conceptualizing potential trends in automated technology which brings environmentally positive effects, reduces pollution and noise, as well as unusual accidents are minimized. Therefore, in a bid to developing a new innovation for transport system; the freight transportation and logistics enables better use of transport infrastructure and contributes to reducing environmental issues (hazards), congestion and distances travelled by truck. The application of the technologies is of high reliability and aiming at the near future introduction. Fuel consumption measurement on a test track and along an expressway shows that the fuel can be saved by about 13 % when the gap was 10 m. The evaluation simulation shows that the effectiveness of the platooning with the gap of 10 m when the 40 % penetration in heavy trucks is 2.1 % reduction of CO₂ along an expressway. Research is developing new and innovative solutions to enhance the environmental sustainability and efficiency of the logistics chain. Significant gains have been achieved by optimizing freight transport infrastructure, by efficiently combining transport modes, and by identifying potential performance, improvement for logistics truck CO₂ emission. However, It would also focus on the effectiveness of low-carbon policy and economy; companies,

governments and financial institutions tends to develop technologically, that is they will encourage companies which implement new technological solutions in the model of truck platooning.

REFERENCE

- [1] Olenych, I. B., & Gukaliuk, A. F. (2017). Application of the Fuzzy Modeling for Optimization of Transport Routes.
- [2] Macioszek, E., Staniek, M., & Sierpiński, G. (2017). Analysis of trends in development of freight transport logistics using the example of Silesian Province (Poland)-a case study. *Transportation Research Procedia*, 27, 388-395.
- [3] Shams, K., Asgari, H., & Jin, X. (2016). Valuation of travel time reliability in freight transportation: A review and meta-analysis of stated preference studies. *Transportation Research Part A: Policy and Practice*.
- [4] Klauenberg, J., Rudolph, C., & Zajicek, J. (2016). Potential users of electric mobility in commercial transport-identification and recommendations. *Transportation Research Procedia*, 16, 202-216.
- [5] Bubel, D., & Szymczyk, K. (2016). The Smart Freight Project as a Superior Way to Cope with Congestion and Environmental Negative Externalities in Urban Areas. *Transportation Research Procedia*, 16, 25-34.
- [6] Muratori, Matteo, Holden, Jacob, Lammert, Michael, Duran, Adam, Young, Stanley, & Gonder, Jeffrey. (2017). Potentials for Platooning in U.S. Highway Freight Transport: Preprint (Vol. 10). United States. doi:10.4271/2017-01-0086
- [7] Liang, K. Y., van de Hoef, S., Terelius, H., Turri, V., Besselink, B., Mårtensson, J., & Johansson, K. H. (2016). Networked control challenges in collaborative road freight transport. *European Journal of Control*, 30, 2-14.
- [8] Tsugawa, S., Kato, S., & Aoki, K. (2011, September). An automated truck platoon for energy saving. In *Intelligent Robots and Systems (IROS), 2011 IEEE/RSJ International Conference on* (pp. 4109-4114). IEEE.
- [9] Macioszek, E., Staniek, M., & Sierpiński, G. (2017). Analysis of trends in development of freight transport logistics using the example of Silesian Province (Poland)-a case study. *Transportation Research Procedia*, 27, 388-395.
- [10] Shams, K., Asgari, H., & Jin, X. (2016). Valuation of travel time reliability in freight transportation: A review and meta-analysis of stated preference studies. *Transportation Research Part A: Policy and Practice*.
- [11] Klauenberg, J., Rudolph, C., & Zajicek, J. (2016). Potential users of electric mobility in commercial transport-identification and recommendations. *Transportation Research Procedia*, 16, 202-216.
- [12] Bubel, D., & Szymczyk, K. (2016). The Smart Freight Project as a Superior Way to Cope with Congestion and Environmental Negative Externalities in Urban Areas. *Transportation Research Procedia*, 16, 25-34.
- [13] Ahmed, S., & Dow, F. M. (2016). Electric vehicle technology as an exploit for cyber attacks on the next generation of electric power systems. 2016 4th International Conference on Control Engineering & Information Technology (CEIT). doi:10.1109/ceit.2016.7929019
- [14] Muratori, Matteo, Holden, Jacob, Lammert, Michael, Duran, Adam, Young, Stanley, & Gonder, Jeffrey. (2017). Potentials for Platooning in U.S. Highway Freight Transport: Preprint (Vol. 10). United States. doi:10.4271/2017-01-0086
- [15] Olenych, I. B., & Gukaliuk, A. F. (2017). Application of the Fuzzy Modeling for Optimization of Transport Routes.
- [16] Liang, K. Y., van de Hoef, S., Terelius, H., Turri, V., Besselink, B., Mårtensson, J., & Johansson, K. H. (2016). Networked control challenges in collaborative road freight transport. *European Journal of Control*, 30, 2-14.
- [17] Tsugawa, S., Kato, S., & Aoki, K. (2011, September). An automated truck platoon for energy saving. In *Intelligent Robots and Systems (IROS), 2011 IEEE/RSJ International Conference on* (pp. 4109-4114). IEEE.
- [18] Maiti, S., Winter, S., & Kulik, L. (2017). A conceptualization of vehicle platoons and platoon operations. *Transportation Research Part C: Emerging Technologies*, 80, 1-19.
- [19] Pel, A. J., Agatz, N., Macharis, C., & Veelenturf, L. P. (2018). Technologies and control for sustainable transportation.
- [20] Attouche, S., Hayat, S., & Staroswiecki, M. (2000, October). A prediction system based on vehicle sensor data in automated highway. In *Intelligent Transportation Systems, 2000. Proceedings. 2000 IEEE* (pp. 494-499). IEEE
- [21] <http://business.edf.org/projects/featured/green-freight/>
- [22] van Doremalen, K. P., Nijmeijer, H., Johansson, H., & Besselink, I. J. M. (2015). Platoon coordination and routing. Master's Internship Report, Eindhoven University of Technology.
- [23] Tsugawa, S. (2013). An overview on an automated truck platoon within the energy ITS project. *IFAC Proceedings Volumes*, 46(21), 41-46.
- [24] <https://www.ucsusa.org/clean-vehicles/vehicles-air-pollution-and-human-health/cars-trucks-air-pollution> accessed (2018, February 13).
- [25] Electric Vehicle And Charging Station Technology As Vulnerabilities Threaten And Hackers Crash The Smart Grid. (2016). Eminent Association of Pioneers (EAP) August 22-24, 2016 Kuala Lumpur (Malaysia). doi:10.17758/eap.eap816010.
- [26] Olenych, I. B., & Gukaliuk, A. F. (2017). Application of the Fuzzy Modeling for Optimization of Transport Routes.
- [27] Macioszek, E., Staniek, M., & Sierpiński, G. (2017). Analysis of trends in development of freight transport logistics using the example of Silesian Province (Poland)-a case study. *Transportation Research Procedia*, 27, 388-395.
- [28] Shams, K., Asgari, H., & Jin, X. (2016). Valuation of travel time reliability in freight transportation: A review and meta-analysis of stated preference studies. *Transportation Research Part A: Policy and Practice*.
- [29] Klauenberg, J., Rudolph, C., & Zajicek, J. (2016). Po-

- tential users of electric mobility in commercial transport-identification and recommendations. *Transportation Research Procedia*, 16, 202-216.
- [30] Bubel, D., & Szymczyk, K. (2016). The Smart Freight Project as a Superior Way to Cope with Congestion and Environmental Negative Externalities in Urban Areas. *Transportation Research Procedia*, 16, 25-34.
- [31] Muratori, Matteo, Holden, Jacob, Lammert, Michael, Duran, Adam, Young, Stanley, & Gonder, Jeffrey. (2017). Potentials for Platooning in U.S. Highway Freight Transport: Preprint (Vol. 10). United States. doi:10.4271/2017-01-0086
- [32] Liang, K. Y., van de Hoef, S., Terelius, H., Turri, V., Besselink, B., Mårtensson, J., & Johansson, K. H. (2016). Networked control challenges in collaborative road freight transport. *European Journal of Control*, 30, 2-14.
- [33] Tsugawa, S., Kato, S., & Aoki, K. (2011, September). An automated truck platoon for energy saving. In *Intelligent Robots and Systems (IROS), 2011 IEEE/RSJ International Conference on* (pp. 4109-4114). IEEE.
- [34] Klauenberg, J., Rudolph, C., & Zajicek, J. (2016). Potential users of electric mobility in commercial transport-identification and recommendations. *Transportation Research Procedia*, 16, 202-216.
- [35] <https://sciencing.com/effects-car-pollutants-environment-23581.html> accessed (2018, February 18).
- [36] <http://www.youngstersofindia.in/home.html> accessed (2018, march 9).
- [37] Bubel, D., & Szymczyk, K. (2016). The Smart Freight Project as a Superior Way to Cope with Congestion and Environmental Negative Externalities in Urban Areas. *Transportation Research Procedia*, 16, 25-34.

Model Identification and Comparative Study of DC Motor Speed Control for Set Point Tracking and Disturbance Rejection

A. A Olaniyan^{*1}, S. A. Abubakar¹, K. R. Ekundayo¹, D.O. Akoh¹, S.M. Dogowa⁵

¹Department of Electrical Engineering, Ahmadu Bello University, Zaria Nigeria

²Department of Communication Engineering, Ahmadu Bello University, Zaria Nigeria

* aaolaniyan@abu.edu.ng

Abstract— Modelling and Identification of dynamic systems constitute an essential stage in practical control and applications. This paper focuses on model identification of an armature controlled laboratory DC motor, rotating in one direction and major techniques for tracking set point commands and suppressing sensitivity to load disturbances. Input-output data of the motor is acquired offline, with the aid of a MATLAB implemented recursive least square algorithm, a linear model transfer function having two poles-one zero is obtained, subsequently simulations in normal MATLAB program and Simulink are carried out to assess the model transient and steady state performances. Result of simulation show that the effect of second control loop secure the integral feedback control point and also secure the target speed. Linear Quadratic Regulator (LQR) gives stable and steady speed on close loop with respect to load and shows that the LQR compensator performs best at rejecting load disturbances.

Keywords— DC motor modelling, Load Torque Condition, LQR compensator, System identification, Tracking set point

1. INTRODUCTION

The applications of direct current (DC) Motors as components of electromechanical systems have remained vital as actuating elements in industrial processes for their advantages of easy speed and position control and wide adjustability range (Sandeep, 2016). DC Motors have been widely used in many industrial applications such as electric vehicles, steel rolling mills, electric cranes, robotic manipulators etc., due to its precise, wide, simple, and continuous control characteristics. Effective use of dc motors requires sound knowledge of the system components and their dynamic characteristics (Shuang, 2010).

DC motors are supposed to operate with high accuracy and speed despite adverse effects of system nonlinearities and uncertainties. This robustness property is of great importance if the system is part of a robotic or servo system, which requires insensitivity to unmodelled dynamics (Lischinsky, 1999). Effect of small load on the motor is absorbed by the kinetic energy of the rotor, under large load change, limitation is imposed on the rotor due to nonlinear behaviour of the magnetization characteristic of the winding circuits (Aisha et al., 2015). The overall effect of such disturbance is that it minimises the speed of the motor and reduces its robustness for specific applications. Several works on Modelling and control of DC motor for performance improvement has been reported in some literatures.

A Simulation of a speed control of DC motor drive using Genetic algorithm (GA) turned PID controller in MATLAB was presented in Shrabani et al., (2013). The work used GA for tuning the speed controller parameter,

and a comparative analysis of proposed technique with the classical method of PID control system applied to DC motor drive was presented. The study shows that the proposed controller enhances the performance of speed control of DC motor drive than the conventional PID controller.

Jide et al., 2015 proposed the feedback method for armature controlled DC motor speed control to enhance the performance of the transient response of the DC motor. The aim was to establish relationship between the speed of DC motor and the load torque at different voltages as well as investigating the performance of closed-loop systems when different voltages are applied to the armature circuit of the motor when a constant voltage is supplied to the field circuit of the motor. The proposed feedback method performance analysis of the modelled system shows that usage of feedback approach enhances the performance of the transient response of the armature controlled DC motor. Someshwar et al., (2016) work proposed a comparative analysis of the DC motor using LAG compensator and PID controller for optimizing the performance for a DC motor. In the work, Root Locus plot, Bode plot and step response were employed to analysed the system and determine its performance improvement. In the work, a LAG compensator and PID controller was applied on an unstable DC motor model in order to obtain a stable model of DC motor for optimal performance.

Most of the cited work adopted models that are analytically derived but in this work, a system identification (SI) technique using offline data acquisition is proposed and analysis of the system will be carried out for transient and steady state performance. In addition to this, the paper will design and compare three DC motor control techniques

namely feedforward command, integral feedback ward control and LQR control for tracking set point and reducing sensitivity to load disturbances to a laboratory DC Motor model provided on TPS-3011. The rest of the work is organised as follows: Section 2 presents the review of a dc motor. Section 3 is dedicated to model identification algorithm analysis and development. Section 4 presents the model performance while section 5 presents the dc motor control design and implementation. Finally, the conclusion of the work is summarized in section 6.

2. REVIEW OF MODEL DEFINITION

An equivalent circuit model of the motor is shown in Figure1

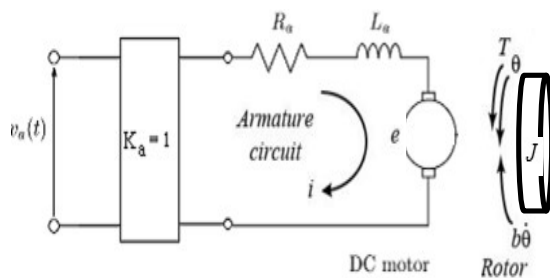

In general, the torque generated by a DC motor is proportional to the armature current and the strength of the magnetic field. Assuming that the magnetic field is constant, therefore, the motor torque (T) is proportional to the armature current i by a constant factor k_t as shown in equation (1). This is referred to as an armature-controlled motor.

$$T = K_t i \tag{1}$$

Mathematically, the back e.m.f, e , is defined as follow:

$$e = K_e \omega \tag{2}$$

where ω is the angular velocity of the shaft and K_e is a constant factor of proportionality. In SI units, the motor torque and back e.m.f constants are equal, that is, $K_t = K_e$ therefore, we will use K to represent both the motor torque constant and the back e.m.f constant. From Figure 1, the following governing equations are derive based on Newton's 2nd law and Kirchhoff's voltage law.

$$J\dot{\omega} + b\omega = K i \tag{3}$$

$$L\frac{di}{dt} + R i = V_a - K\omega \tag{4}$$

Since the intended model structure for the system in this study is the transfer function model, applying the Laplace transform to equations (3) and (4) in terms of the Laplace variable s yield equations (5) and (6)

$$s(Js + b)\theta(s) = K i(s) \tag{5}$$

$$(Ls + R)I(s) = V(s) - K(s)\theta(s) \tag{6}$$

The open-loop transfer function after eliminating $I(s)$ between equations (5) and (6) and relating the rotational speed and the armature voltage yields:

$$G\theta(s) = \frac{\omega(s)}{v_a(s)} = \frac{k}{(Ls + R)(Js + b)} \tag{7}$$

where $\omega(s)$ is rotor speed, $V(s)$ is input voltage, R armature resistance, J is rotor inertia, b is viscous friction constant, and K is back e.m.f. constant.

2.1 Model Identification

If input u , and output v is put in vector form as:

$$P = [u(1), v(1), \dots, u(N), v(N)]^T$$

Then a compact model can be written as:

$$y(t) = \varphi^T(t)\theta \tag{8}$$

where;

$$\theta = [a_1, \dots, a_m, b_1, \dots, b_m]^T \text{ and}$$

$$\varphi = [-y(t-1), \dots, -y(t-n), u(t-1), \dots, u(t-m)]^T$$

are vectors of estimated parameters and past values of input-output vector respectively. A recursive least square for estimating the parameter vector θ is given as Ljung (1987):

$$\hat{\theta}^N = [\sum_{t=1}^N \varphi^T(t)\varphi(t)]^{-1} \sum_{t=1}^N \varphi(t)y(t) \tag{9}$$

However, the MATLAB identification toolbox was used to generate a set of codes that generate transfer function from the estimated parameter employ in equation (9).

In modelling a DC motor connected to a load via a shaft, the general approach is to neglect the nonlinear effects and build a linear transfer function representation for the input-output relationship of the DC motor and the load it drives (Nayana et al., 2013). This assumption is satisfactorily accurate and valid as far as conventional control problems are concerned. Giving a system input-output data, a numerical software such as MATLAB implements recursively the algorithm and gives an estimate of the parametric model of the system in form of state space, transfer function or ARX model.

2.1.1 System Data Acquisition

The input and output signals are sampled offline at an estimated time interval of 5 seconds. Input is applied through fixed amplifier gain K from the on-board potentiometer. Output is a speed tacho-generator providing dc voltage as a measure of the motor speed. The test bed for collection of data is shown in Figure2.

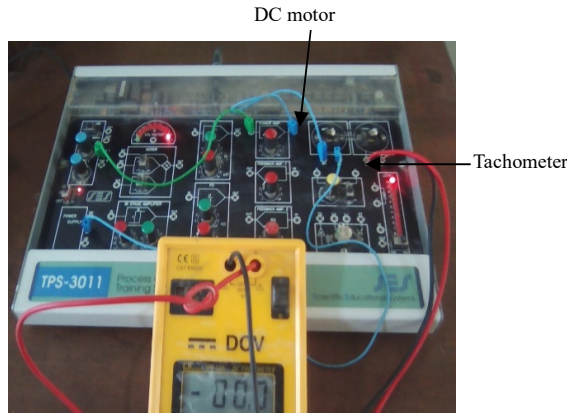

Figure 2: Process Kit with Offline DC Motor Data Acquisition Set Up

The number of input-output sampled obtained was 160 and the data samples is presented in Appendix A.

2.1.2 Model Estimation

Accurate model building is a crucial stage in practical control problems. An adequately developed system model is essential for reliability of the designed control. When the plant has uncertainties or time dependencies, or cannot be parameterized, a model for the system may be hard to obtain. For such systems, the system parameters should be determined using system identification techniques. In light of this, MATLAB identification toolbox code for model estimation is provided with the data after pre-processing. Amplifier gain is fixed at $K_p = 0.9791$ representing the dc gain of the motor. Using the Predictive Error algorithm (PEM) with specified structure having two poles, no zero, MATLAB returns the following model structure:

$$G(s) = \frac{K_p(s^2 + \tau_1 s + \tau_2)}{s^2 + \tau_z s} \tag{10}$$

The poles time constants estimates are: $\tau_1 = 0.071$, $\tau_2 = 0.071$. And zero-time constant estimate is $\tau_z = 1.94$. With the given time constants estimated and substituted into (10), the systems transfer function is given as:

$$G(s) = \frac{0.9791(s^2 + 0.071s + 0.071)}{s^2 + 1.94s} \tag{11}$$

3. SYSTEM PERFORMANCE ANALYSIS AND SIMULATION

Performance of industrial systems are greatly affected by the following types of nonlinearities:

1. Parameter variations
2. Sudden shock; due to large surge in their primary signal input or at some location along the signal path
3. Signal Impact that is sustained
4. Noise in measurement
5. Load variations
6. Nonlinearities in many parts of the system

In this work, the model was simulated based on the fol-

lowing two case scenarios: Case1 is based on Model response under no load condition while Case 2 is Model response under load torque condition with compensation.

3.1 Model response under no load condition,

The response of the developed model to a unit step input case is obtained and step response plot presented in Figure 3

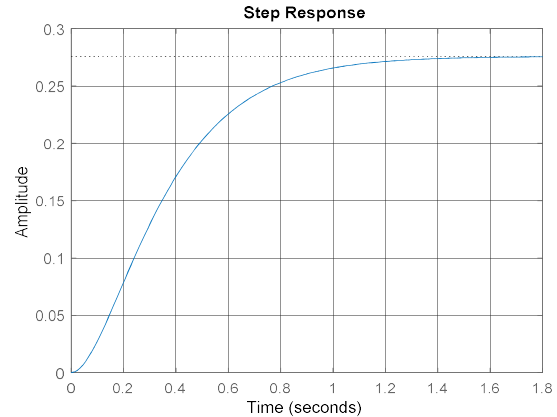

Figure 3: Model response to unit step

Figure 3 shows that the system has large steady state error of about 74.5% while the settling time was about 1.6 seconds.

3.2 Model Response Under Load Torque Condition with Compensation

In this case, the systems response was obtained using different control techniques while subjecting the system to disturbance perturbation. The implementation and results are described as follow:

3.2.1 Feedforward DC Motor Control Design

The feed forward control structure to command the angular velocity ω to a given value ω_{ref} is presented in Figure 4

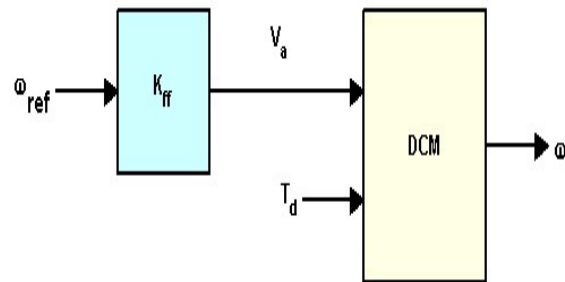

Figure 4: Feedforward control structure

The Feedforward is an open loop system with Voltage control V_a . Taking K_{ff} as DC motor gain, which is defined and set to the reciprocal of the DC gain from V_a to ω .

$$K_{ff} = \frac{1}{dcm(1)} * (dcm(1)) \tag{12}$$

where; $K_{ff} = 3.5049$

To evaluate the feedforward design in the face of load disturbances, the systems response to a step command

$\omega_{ref} = 1$ with a disturbance $T_d = -0.5 Nm$ and $-1.0 Nm$ between $t = 5s$ and $t = 10s$ were simulated and results are presented in Figure 5 (a) and (b) respectively.

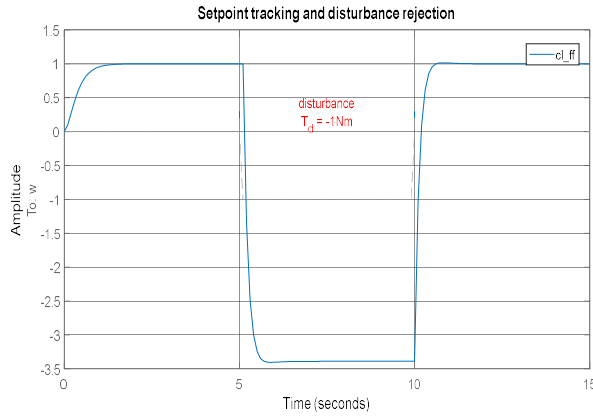

(a)

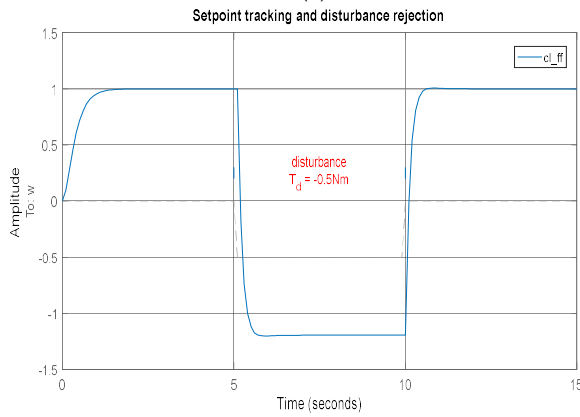

(b)

Figure 5 (a) and (b): DC motor Stepping and disturbance rejection for feedforward control

3.2.2 Feedback DC Motor Control Design (Root locus)

To enforce zero steady-state error, the use of integral control as shown in equation (12)

$$C(s) = \frac{K}{s} \tag{13}$$

To determine the gain K, the root locus technique is applied to the open-loop $\frac{1}{s} * Transfer[V_a \rightarrow \omega]$. Figure 6 shows the complete control structure for this approach.

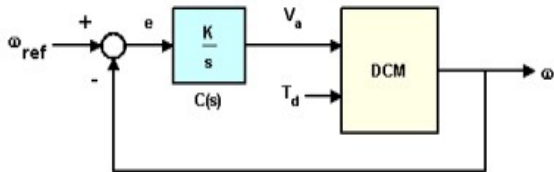

Figure 6: Feed backward control structure

The main idea of root locus design is to obtain the closed-loop response from the open-loop root locus plot for the DC motor response. By adding zeroes and poles to the original system, the root locus is modifiable using a new closed-loop response. Foremost, the root-locus for the system itself imposed with a unit circle. Figure 7 shows the root locus plot used for determining the feed backward

closed-loop gain.

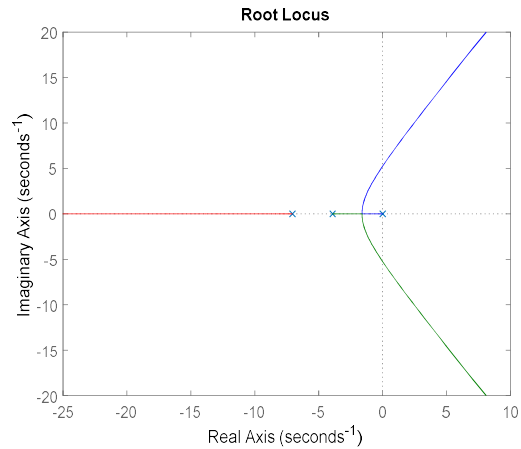
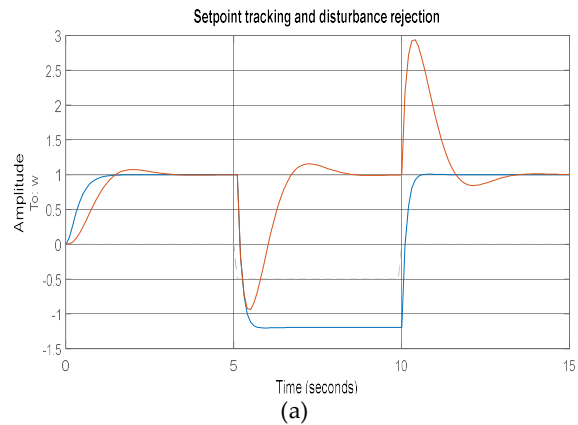
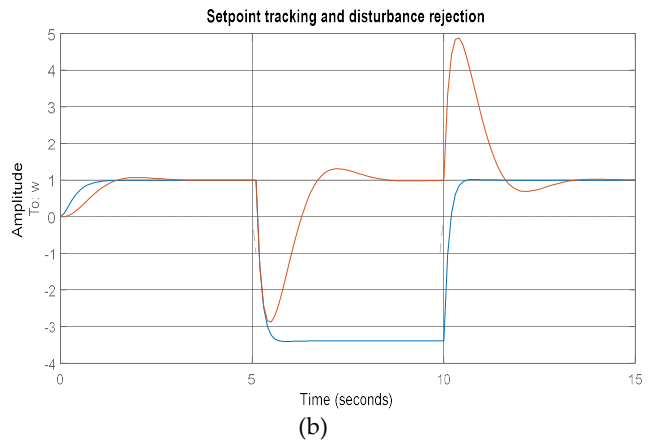

Figure 7: Root Locus design method for the DC motor system

The gain value is read from the plot to be 4.5, but a reasonable choice used in this work is $K = 5$. By Comparing this new design with the initial feed forward design on the same test case, plots for the stepping and disturbance rejection are presented in Figure 8(a) and (b):



(a)



(b)

Figure 8(a) and (b): DC motor Stepping and disturbance rejection for feedforward and feed backward control

3.2.3 LQR DC Motor Control Design

To further improve performance, try designing a linear

quadratic regulator (LQR) for the feedback structure shown Figure 9:

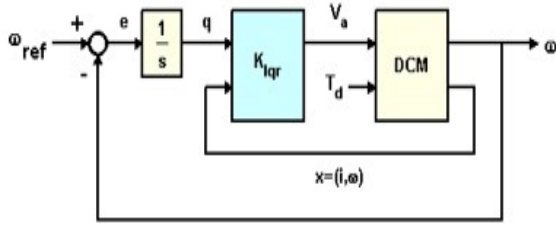
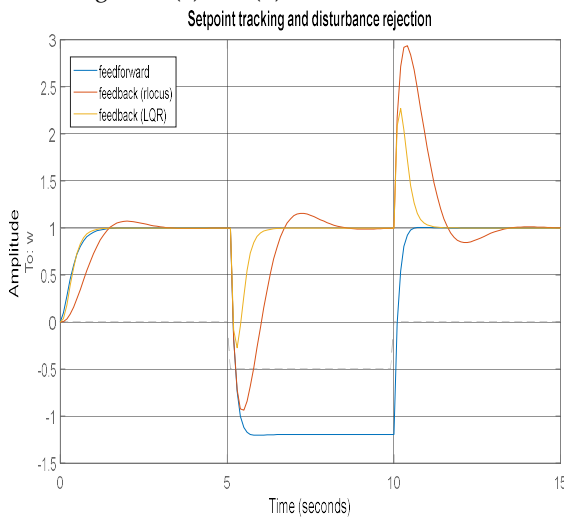
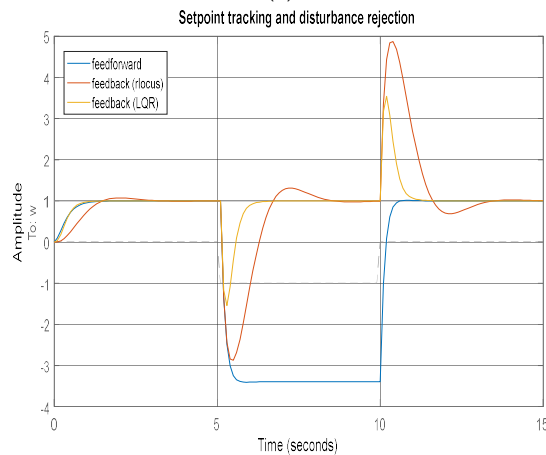

Figure.9: LQR control structure

In addition to the integral of error, the LQR scheme also uses the state vector $x = (i, \omega)$ to synthesize the driving voltage V_a . The optimal LQR gain for this cost function is computed and the closed-loop model response is presented in Figure 10(a) and (b).



(a)



(b)

Figure 10 (a) and (b): DC motor Stepping and disturbance rejection for the 3 control techniques

4. DISCUSSION OF RESULTS

Feedback (closed-loop) control can be used to stabilize systems, speed up the transient response of the DC motor,

improve the steady-state characteristics, provide disturbance rejection state, and decrease the sensitivity to parameter variations. From the result shown in figure 5(a) and (b), it can be observed clearly that the feed forward control handles load disturbances poorly as it remained sensitive to the disturbance over the entire range of time.

The root locus design approach proves to be better at rejecting load disturbances as compared to the feed forward approach and this can be seen in Figure 9(a) and Figure 9 (b) for load torque of -0.5 and -1 Nm respectively. Figure 10(a) and Figure 10(b) is a plot of the system response to the three (3) control techniques and the LQR compensator performs best at rejecting load disturbances (among the three DC motor control designs discussed). Table 1, shows the summary of the system response for both steady state and transient state performance for the 3 control technique

Table 1: Performance indices for load torque of -0.5 and -1.0 Nm

Technique	Rise time	Settling time with load torque	Steady state error
Feed forward	1.80	6.00	0.00
Feed backward	2.00	3.20	0.00
LQR control	1.80	1.20	0.00

5. CONCLUSION

The result shows that the developed is in conformity with other work. DC Motor model identification and control designed has been successfully achieved using MATLAB program to track the motor speed set point under loading and without load. The simulation results show that in terms of steady state, both techniques perform robustly while in terms of transient performance characterized by disturbance rejection capabilities, the LQR technique has a better performance amongst the other three control techniques.

REFERENCES

- [1] Abdulrahman A.A.E., Rosbi B.M., (2014) Modeling and Simulation for Industrial DC Motor Using Intelligent Control. International Symposium on Robotics and Intelligent vol. 43, no. 3, pp. 113-120,
- [2] Aisha J., Sadia M., SyedOmar J., (2015). Controlling Speed of DC Motor with Fuzzy Controller in Comparison with ANFIS Controller. Intelligent Control and Automation, 2015, vol. 6, pg. 64-74 <http://www.scirp.org/journal/ica> <http://dx.doi.org/10.4236/ica.2015.61008>

- [3] Jang J., Jeon G.J., (2000), A Parallel Neuro-Controller for DC Motors Containing Nonlinear Friction, *Neuro-Computing*, 30:233-248
- [4] Jide J., Popoola O. Joshua O., and Charity S.O., (2015). Modelling and Simulation of Armature-Controlled Direct Current Motor Using MATLAB. *SSRG International Journal of Electrical and Electronics Engineering (SSRG-IJEEE)*, volume2, Issue 3 ISSN: 2348 –8379 www.internationaljournalssrg.org
- [5] Lischinsky P, Canudas-de-Wit C, Morel G. (1999) Friction compensation for an industrial hydraulic robot. *IEEE Control System Management* ;19(1):25–32.
- [6] Ljung L., (1987), *System Identification: Theory for the User*, Englewood Cliffs, NJ, USA: Prentice Hall
- [7] Mummadi V.C., (2000), Steady State Dynamic Performance Analysis of PV Supplied DC Motors Fed from Intermediate Power Converter, *Solar Energy Mater Solar Cells*, vol.61, pp.365-381.
- [8] Nayana P., Mahajan S.B.D., (2013). Study of Non-linear Behaviour of DC Motor Using Modelling and Simulation. *International Journal of Scientific and Research Publications*, Volume 3, Issue 3, ISSN 2250-3153 www.ijsrp.org
- [9] Nordin M., Gutman P., (2002), Controlling Mechanical Systems with Backlash – A Survey, *Automatica*, No, 38, vol. 10, pp.1633-1649
- [10] Sandeep G., Meena T., (2016) Analysis DC Motor Nonlinear Behaviour Using Modelling and Simulation. *International Journal of Advanced Research in Electrical, Electronics and Instrumentation Engineering*. Vol. 5, Issue 1.
- [11] Sandeep G., (2015). To Control the Characteristics of AC Motor Using Fuzzy Logic Controller”, in *IJEEE*, Vol. No.7, Issue No. 01,
- [12] Sandeep G., (2013), “Recent trend in generation of electricity” in “International Conference on science and engineering contribution in world development, DRDO, Delhi” held in Dec, 2013.
- [13] Shuang C., Guodong L., Xianyong F., (2010). “Parameter identification of Nonlinear DC Motor model using compound evolution Algorithms”, *Proceedings of the World Congress on Engineering 2010 Vol I*, London, U.K.
- [14] Shrabani P., Jayanta B.B., (2016). Performance Enhancement of DC Motor Using Genetic Algorithm. *International Journal of Science and Research (IJSR)* ISSN (Online): 2319-7064, Volume 5 Issue 1
- [15] Someshwar D., Pathak V.K. Tripathi (2016). A Comparative Study of DC Motor for Optimal Performance Using LAG Compensator and PID Controller Implemented by MATLAB. *International Journal of Advanced Research in Computer and Communication Engineering* Vol. 5, Issue 5
- [16] Tolgay K. and Ilyas E., (2003). Nonlinear Modelling and identification of a DC motor for bidirectional operation with real time experiments, *Free Online stuff*, Retrieved October 2011 from www.elsevier.com/locate/enconman
- [17] Wu R-h, Tung P-C, (2002). Studies of Stick-slip Friction, Pre-sliding Displacement and Hunting, *journal of Dynamic Systems- Trans ASME*, 124:111-117

Appendix A: Dc Motor Input-Output Data

S/N	INPUT (V)	OUT-PUT (V)	S/N	INPUT (V)	OUT-PUT (V)	S/N	INPUT (V)	OUT-PUT (V)	S/N	IN-PUT (V)	OUT-PUT (V)
1	0.96	0.21	41	4.88	8.53	81	2.34	2.93	121	4.02	6.16
2	1.09	0.49	42	4.86	8.22	82	2.27	2.81	122	4.05	6.32
3	1.25	0.77	43	4.82	7.99	83	2.14	2.48	123	4.12	6.42
4	1.55	1.35	44	4.80	7.87	84	2.02	2.32	124	4.22	6.58
5	1.66	1.52	45	4.78	7.72	85	1.94	2.29	125	4.28	6.68
6	1.74	1.68	46	4.67	7.51	86	1.91	2.18	126	4.31	6.81
7	1.87	1.93	47	4.55	7.25	87	1.89	2.03	127	4.37	6.95
8	1.97	2.14	48	4.46	7.07	88	1.67	1.74	128	4.49	7.11
9	2.06	2.30	49	4.36	6.88	89	1.65	1.63	129	4.51	7.22
10	2.14	2.46	50	4.21	6.58	90	1.56	1.48	130	4.54	7.27
11	2.31	2.80	51	4.16	6.46	91	1.54	1.41	131	4.57	7.35
12	3.46	5.12	52	4.08	6.31	92	1.44	1.36	132	4.66	7.43
13	3.58	5.38	53	4.01	6.18	93	1.42	1.30	133	4.73	7.62
14	3.67	5.52	54	3.97	6.10	94	1.38	1.25	134	4.80	7.79
15	3.73	5.66	55	3.93	6.01	95	1.21	1.20	135	4.82	7.83
16	3.77	5.76	56	3.87	5.95	96	1.18	1.15	136	4.88	7.89
17	3.82	5.88	57	3.82	5.87	97	1.08	1.09	137	4.91	7.98
18	3.84	5.93	58	3.77	5.72	98	1.05	1.01	138	4.96	8.29
19	3.90	6.01	59	3.67	5.46	99	1.03	0.73	139	4.94	8.57
20	3.96	6.09	60	3.61	5.38	100	0.69	0.48	140	4.90	8.02
21	4.00	6.16	61	3.51	5.19	101	0.86	0.21	141	4.88	7.99
22	4.07	6.32	62	3.42	5.01	102	1.08	0.49	142	4.87	7.87
23	4.12	6.42	63	3.32	4.82	103	1.22	0.77	143	4.82	7.72
24	4.20	6.58	64	3.27	4.72	104	1.53	1.35	144	4.79	7.49
25	4.26	6.68	65	3.21	4.62	105	1.60	1.52	145	4.76	7.35
26	4.32	6.81	66	3.16	4.49	106	1.77	1.68	146	4.65	7.08
27	4.39	6.95	67	3.09	4.37	107	1.87	1.93	147	4.54	6.74
28	4.47	7.11	68	2.99	4.18	108	1.93	2.14	148	4.46	6.48
29	4.53	7.22	69	2.91	4.02	109	2.00	2.30	149	4.38	6.36
30	4.55	7.27	70	2.83	3.87	110	2.18	2.46	150	4.27	6.29
31	4.59	7.35	71	2.75	3.71	111	2.51	2.80	151	4.20	6.18
32	4.63	7.43	72	2.69	3.59	112	3.47	5.12	152	4.16	6.10
33	4.73	7.62	73	2.61	3.43	113	3.59	5.38	153	4.09	6.01
34	4.81	7.79	74	2.53	3.26	114	3.66	5.52	154	3.99	5.95
35	4.84	7.83	75	2.43	3.07	115	3.75	5.66	155	3.93	5.87
36	4.87	7.89	76	2.32	2.87	116	3.77	5.76	156	3.88	5.72
37	4.91	7.98	77	2.18	2.64	117	3.80	5.88	157	3.80	5.46
38	4.97	8.09	78	2.14	2.59	118	3.82	5.93	158	3.77	5.38
39	4.94	8.12	79	2.09	2.51	119	3.89	6.01	159	3.67	5.19
40	4.90	8.18	80	2.04	2.43	120	3.96	6.09	160	3.52	5.01

Formation of Ceiling Boards by the Combination of Sugarcane Bagasse and Rice Husk

Seun I. Jesuloluwa* and Ige Bori

¹Department of Mechanical Engineering, Federal University of Technology, Minna
*jesuloluwaseun@gmail.com

Abstract – Constructing housing components from agricultural wastes have become a special area of research in engineering. Hence a lot of resources is pushed into this to obtain sustainable, eco-friendly and low-cost houses. This work studies some properties of ceiling boards produced from sugarcane bagasse and rice husk. The ceiling boards were produced using water, cement as binder with binder composite ratio of 3:2 by weight, sugarcane bagasse and rice husk of varying ratios by weight from 100% of bagasse to 0% of it with a 25% decrease. The compression of the boards was done manually using moulded block as weight. From the results, it was observed that the ceiling board produced with 100% sugarcane bagasse has better properties to be considered for ceiling board as compared with the most commonly used ceiling boards like Plaster of Paris (POP), asbestos and Poly Vinyl Chloride (PVC). The properties examined are thermal conductivity, thermal resistivity, water absorption and density. The better ceiling board has thermal conductivity to be 2.27W/mK, thermal resistivity of 0.441 mK/W, water absorption of 16.89 and density of 470.3 kg/m³.

Keywords – ceiling board; rice husk; sugarcane bagasse; thermal conductivity; thermal resistivity.

3 INTRODUCTION

Ceiling boards are slabs usually horizontal that covers the upper part of a room or internal space. It is not generally considered a structural element, but a finished surface concealing the underside of the roof structure or the floor of a storey above.

It is a shell concealing a roof structure above it. Roof structures could be plain, carry pipes or carry acoustic and thermal insulation. In modern buildings, ceilings carry electric light, security cameras, smoke detectors and more. There are several ceiling materials used in Nigerian homes such as asbestos, Plaster of Paris (P.O.P), Poly Vinc Chloride (PVC) and some use wood each having its own advantages and disadvantages. Some of these have been found to be hazardous to health especially the asbestos which is the most common in the average Nigerian home. Agriculture is native to Nigeria, hence a lot of waste is generated in the farm, during processing and during consumption. Hence a lot of research has been going on to check how agricultural wastes can be used as ceiling boards among other applications which will also compete favorably with the characteristics of the existing ones.

4 LITERATURE REVIEW

2.1 Wood wool composite board

A research on the mechanical properties of wood wool cement composite board using some selected Malaysian timber species was carried out [1]. The work involved using a cement to wood wool ratio of 2 to 1 by weight to make the composite board. From the result obtained, it was found out that the mechanical properties of the board were influenced by the density such that as the mechanical strength decreased as the density decreased. Also, the compressive strength increased with the thicker boards (50mm and 75mm) while as the thickness increased, the modulus of elasticity and modulus of rupture decreased.

2.2 Water melon peels

The suitability of using water melon peels as alternatives to wood-based particleboard composites was studied [4]. Water melon peels composite boards by compressive moulding using recycled low-density polyethylene (RLDPE) as a binder was produced. The RLDPE was varied from 30 to 70% by weight at intervals of 10%. The microstructure, water absorption (WA), thickness swelling index (TS), modulus of rupture (MOR), modulus of elasticity (MOE), internal bonding strength (IB), impact strength and wear properties of the boards were determined. The results showed that high modulus of rupture of 11.45 MPa, MOE of 1678 MPa, IB of 0.58 MPa, wear rate of 0.31 g was obtained from particleboard produced at 60% RLDPE. From the investigation, it was concluded that water melon particles can be used as a substitute to wood-based particleboards for general purpose applications. Aside from being environmental friendly, using water-melon and RLDPE in production of particleboard, it was also found to be very cost-effective.

2.3 Jatropha seed cake

Similarly, a study on the estimation of the properties of composite ceiling boards that employ the use of wood waste particles and jatropha seed cake was carried out [6]. In this work, Predictive models for the simulating physical and mechanical properties of the composite products was done; and used to study the characteristics of bulk density (BD), thickness swelling index (TS), modulus of rupture (MOR), modulus of elasticity (MOE) and internal bonding strength (IB) of the composite ceiling boards analyzed.

Using Equal amounts of jatropha and sawmill dust in the theoretical composite particle/ceiling board, it resulted in values of properties, bulk density 0.8975 g/cm³, thickness swelling index 9.83%, modulus of rupture 25.05 MPa, modulus of elasticity 2.42 GPa and internal bonding strength 13.86 MPa respectively. It was found out that Improved mechanical properties and denser composite

particle/ceiling board can be produced with addition of jatropa to sawmill dust under specified control conditions of fiber-matrix mixture aggregates.

2.4 Rice husk and waste paper

Likewise, the properties of ceiling boards produced from a composite of waste paper(WP) and rice husk(RH) was researched [2]. The composite was prepared using hot water starch as binder. The number of composites prepared were six varying from 100% of rice husk (RH) reducing downward to 0% while the waste paper started from 0% to 100% in a range of 20% each. Samples were prepared to suit the tests to be carried out. They were then oven dried under the temperature of 80°C for 24 hours. Then the samples were tested for water absorption, density, thermal conductivity modulus of elasticity and flexural strength properties. It was observed that the water absorption capacity of the composite material varies between 7.5% and 14.5% and this increases with an increase in waste paper(WP) content. Furthermore, it was found out that the composite exhibited a decreasing thermal conductivity with increasing WO content varying between 0.082- 0.07kW/MK for 0%:100% WP/RH mix to 100%:0% WP/RH mix respectively. Also, the density test showed that the density exhibited a decreasing trend with increase in WP content.

2.5 Sugarcane Bagasse and wood particles

A three-layer experimental particleboard using a mixture of bagasse and industrial wood particles was also investigated [3]. The boards produced were with ratio of the mixture of bagasse and wood particles, in the surface and middle layers given as 20:80, 30:70 and 40:60, respectively using the press times at two levels of 5 and 7 minutes. Two levels of urea formaldehyde resin were selected for the surface layers, namely: 9 and 11 percent. The Modulus of elasticity (MOE), modulus of rupture (MOR), internal bonding (IB) and thickness swelling (TS) of the panels were determined. The results indicated that all mechanical and physical properties of particleboards improved with an upper percentage of bagasse particles added. It was also observed that the treatment with 40% bagasse, 11% resin in the surface layers and with a 7 min press time resulted in an optimum particleboard product.

Haven reviewed literature, it was noted that investigation on the combination of sugarcane bagasse and rice husk has not been done. Therefore, the aim of this study is to investigate some mechanical properties such as thermal conductivity, water absorption, density of locally produced ceiling boards from a combination of sugarcane bagasse and rice husk using cement as its binder.

3 METHODS

The Rice husk used in this study were obtained from a rice mill in Bida, Niger state and the sugarcane bagasse were gotten on the streets of Minna as they were freshly chewed. The Sugarcane bagasse was sun dried for seven days until there was no significant water content. This was ensured by weighing and reweighing after drying using a

weighing scale. After the sugarcane was dried, they were sent to the grinding mill to reduce its size. Then, a sieving mesh was used to sieve and get an average size after grinding. The Rice husk was of an appropriate size because they were obtained from the mill.

Ordinary Portland cement was used as binder and was obtained from the building material market in Minna. Hand trowel for mixing was also gotten from the same market. Metallic mould of size 500mm by 300mm by 30mm was manufactured at a welding workshop for the purpose of the study. Furthermore, polyvinyl chloride (PVC), Plaster of Paris (POP) and asbestos ceilings were obtained also so as to compare its property also while testing the manufactured board.

3.1 Preparation of the cement bonded board

Composite, cement in the ratio of 3:2 (respectively by weight) and water, were mixed thoroughly until all the mixture was coated with cement paste. A layer of polyethylene was laid in the mould to enhance easy demoulding. Then the cement composite mix is then carefully spread out into the metallic mould. After pouring the mix into the mould, another layer of polythene was place on the mix to prevent the board from sticking to the mould cover during compression. The board was then pressed with the use of blocks for 2-3 days and the demoulded. After demoulding, the boards were cured by wetting and air drying for up to 21days. A total of 10 boards were produced consisting of 2 samples each for the following sugarcane bagasse to rice husk content ratio, 100:0, 75:25, 50:50, 25:75, 0:100 by weight.

3.2 Test Method

The following are the tests carried out and how they were done.

3.2.1 Thermal Conductivity λ:

The thermal conductivity test was conducted by steady plate method according to American society for testing and materials (ASTM) E1225 using a thermal conductivity meter (as shown in appendix A).

The probe consists of a single heater wire and thermocouple. When constant electric power (energy) is given to the heater, the temperature of the wire will rise in exponential progression. Temperature rising curve is plotted in linear line with time axis scaled in logarithm. The angle of this line increases if the sample has less thermal conductivity, and decreases if it has higher Thermal conductivity. Therefore, the thermal conductivity of a sample can be determined from the angle of the rising temperature graphic line. The formula used to calculate the thermal conductivity is as shown.

$$\lambda = \frac{q \cdot t}{A \cdot (t_2 - t_1)} \tag{1}$$

- λ ; thermal conductivity of sample [W/mK]
- q ; generated heat per unit length of sample/time [W/m] = 500 for all, but 50 for PVC.
- t₁, t₂ ; measured time length [min]

T_1, T_2 : Temperature at t_1, t_2 [K]

3.2.2 Thermal resistivity

Thermal resistance is the ability of a material to resist flow of heat. Thermal resistivity is the reciprocal of thermal conductivity and can be expressed as

$$r = 1/\lambda \tag{2}$$

Where r =thermal resistivity(mK/W)

3.2.3 Density:

This test was carried out according to the ASTM D1475 method. Sample was poured into the pycnometer and weighed. The weight was recorded as W , and the weight of the empty pycnometer as, w , in grams. The density was calculated in grams per milliliter as follows:

$$D = \frac{W - w}{V} \tag{3}$$

Where:

D = density g/ml. (1g/ml=1000kg/m³)

V = volume of pycnometer ml

3.2.4 Water Absorption Test

The samples were air dried at 323 K up to a constant weight and then immersed in a static deionized water bath. The specimens were taken out of the water at certain periods of time, wiped with tissue paper to remove surface water, reweighed and immediately put back into the water. The water absorption test was conducted according to ASTM D570 method. At least three specimens for each sample were used and the average values were reported. The percentage of water absorption (WA) was calculated by the weight difference between the samples exposed to water and the dried samples according to the following equation:

$$WA(\%) = \frac{M_f - M_i}{M_i} * 100 \tag{4}$$

where: M_f is the mass of the sample after immersion (g)

and M_i is the mass of the sample before immersion (g).

The water absorption was determined by weighing on a balance with precision of 0.001 g.

4 RESULTS AND DISCUSSIONS

The thermal conductivities and resistivities of the composite as compared to the available ceiling boards are summarized in figure 1

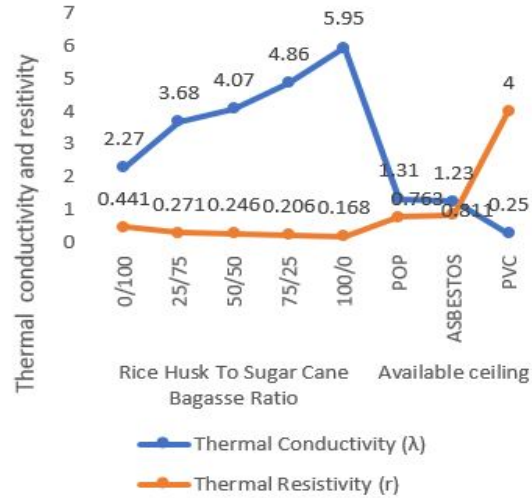

Figure 1: Thermal conductivity and resistivity test result from the composite and available ceiling

The results showed that the thermal conductivity of the composite increased as the amount of the rice husk increased. This is to say that sugar cane bagasse has a higher thermal resistance than rice husk. Among the available ceiling boards currently in used, the widely used POP has a lower thermal resistivity than the rest of its counterparts while PVC has the highest resistivity.

The above results show that using sugarcane bagasse alone to make a ceiling board will suffice for thermal applications. It will be more efficient if used with another binder that can withstand hot compress. Also, there is a possibility that it will compete with POP for thermal applications if some additives are added to it.

The water absorption of the composite as compared to the available ceiling boards are as shown in figure 2

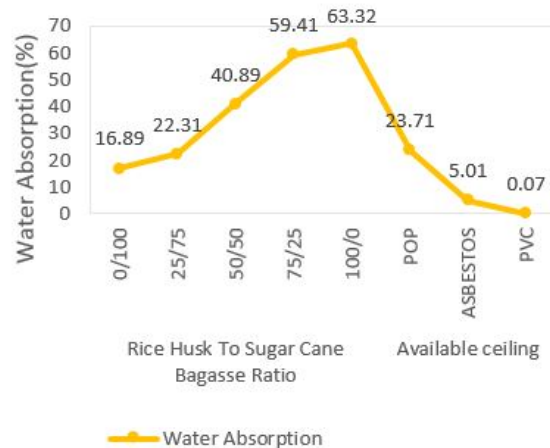

Figure 2: Water absorption test result from the composite and available ceiling

The results show that the water absorption also increase as the percentage of the rice husk increased. This trend is similar to what was observed by that the water absorption capacity is more in composites having more

rice husk [5]. The ratios with the lowest absorption are rice husk to bagasse ratios 0:100 and 25:75. And these ratios are higher than Plaster of Paris. Asbestos and PVC are far away from it and are better for water absorption.

The result for density of each composite is as shown in figure 3

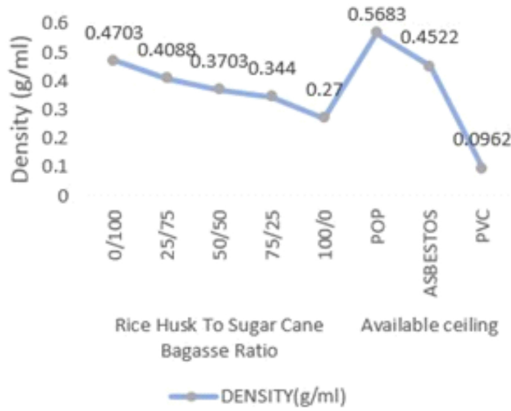

Figure 3. Density test result from the composite and available ceiling

The density of the composites decreased with an increase in the percentage of rice husk. The densest has been the one with lower thermal conductivity and water absorption.

5 CONCLUSIONS

In conclusion, the result of this experimental study showed that the most applicable composite as compared with the available ceiling materials for use for thermal applications is the ratio 0:100 (Rice husk: Sugarcane bagasse). Also, the higher the density the better for use as ceiling board.

After this study it can be recommended that the following are done for further improve on the quality and usability of this kind of ceiling board

- i. A water-resistant binder be used to improve the water absorption rate of the materials.
- ii. Ceiling boards be produced with a hot press as this might impact the thermal conductivity.

6 ACKNOWLEDGMENTS

I will love to thank Dr. Bori Ige for his guidance leading to the successful completion of this work

7 REFERENCES

[1] Ahmad Z., Wee L.S. and Fauzi M.A. Mechanical properties of wood-wool cement composite board manufactured using selected Malaysian fast grown timber species in *ASM Science Journal* · January 2011 pg 27-35.

[2] Ataguba, C.O. Properties of ceiling boards produced from a composite of waste paper and rice husk, *International Journal of Advances in Science Engineering And Technology*, ISSN;2321-9009, Feb 2016

[3] Ghalehno, M. D., Nazerian, M. and Bayatkashkoli, A.: *Experimental Particleboard from Bagasse and Industrial Wood Particles*, *International Journal of Agriculture and Crop Sciences*, 5 (15): 1626-1631, 2013.

[4] Idris, U. D., Aigbodion, V. S., Atuanya, C. U. and Abdullahi. J.: Eco-Friendly (Water Melon Peels): Alternatives to Wood-based Particleboard Composites, *Tribology in Industry*, 33(4): 173-181, 2011.

[5] Isheni Yakubu, Yahaya B.S, Mbishida M.A, Achema Felix, Karfe Gayus S.: Production of Agro waste composite ceiling board (a case study of the mechanical properties), *Journal of scientific and Engineering Research*, 4(6):208-212, 2017.

[6] Olorunmaiye, J. A., Ohijeagbon, I. O. *Journal of Production Engineering* Volume 18(2) 2015 Retrofitting composite ceiling boards with jatropha curcas seedcake material

8 APPENDIX A



Prioritised Hybrid Automatic Transfer Switch with Two Generators Shift

Abubakar S. Muhammad¹, Ibrahim Bala², Abubakar Sadiq Muhammad³, Abdulkadir A. Yako¹ and Abdulkadir H. Kofar Naisa¹

¹Department of Electrical and Electronics Engineering, Kano State Polytechnic, Kano, Nigeria.

²Transmission Company of Nigeria, Oyo State, Nigeria.

³ Department of Computer Engineering, Kano State Polytechnic, Kano, Nigeria

[*abubakarsan747@gmail.com](mailto:abubakarsan747@gmail.com)

Abstract— Due to epileptic availability of electrical power supply for industrial or domestic use, especially in developing countries, the need for continuity of electricity supply is inevitable, for this reason, this Microcontroller Based Prioritized Automatic Transfer Switching system is designed to use four sources namely; public utility, solar, generator1 and generator2, to change from one of them to another with priority given. Utility is given the top priority followed by solar and then generator1 will run for six hours while checking other sources, if any of them is returned, then it will be disconnected and switched off, then the load is reconnected to the existing source, otherwise if the hours elapsed and no return of power from the other sources, then generator2 is connected for the next six hours as in the case of generator1. The cycle will be repeated continuously. The manual method used for the switching system is a major setback and can make the entire process vulnerable to fire outbreak, inefficiency and wastage of time. In this paper, the proposed design will bring an improvement and eliminates potential dangers, risk associated with ordinary manual transfer switching system, continuity of supply and hence greater transformation in technological advancement of the switching system. A pic16F877A microcontroller is used to coordinate the activities of voltage sensing circuitry (for utility, solar and generators respectively), LED indicators and relay driver. A proposed block diagram of the system and flow chart were developed, the programming for the microcontroller is carried out using pickit2 programmer (in C++ programming language). Proteus suit software was used to simulate the system. The workability of the system designed was proved successful from the simulation result and the duration it takes for the system design to operate is about less than a second unless for generators where delay of about twenty seconds is observed for switching and stability.

Keywords: Automatic Transfer Switching (ATS) System; Generator; Microcontroller; Solar; Utility,

1 INTRODUCTION

Generally organization's development is distracted by intermittent power failure or constant outage. In countries where there is instability of power, investment does not easily succeed, industrial transformation cannot be easily sped up, however a heavy loss may result when some processes are interrupted such as surgery in health care organization and some online financial proceedings in government and private agencies [1].

To avoid these inconveniences, secondary source of power is mostly introduced to cushion undesirable effect of any unprecedented power failure. The transition can be achieved by means of an ATS.

A load can be switched from many sources of power (conventionally two) by means of an ATS. It ensures that a minimum gap between the power failure and load reconnection to secondary source of power is maintained. The ATS comes in between the power sources and the load to be connected in order to disconnect the load from the utility supply when there is no electricity and transfer it to secondary supply for sustainability of load operation, it then connects it back to the original supply upon restoration of power [2].

In the system existing, power failure can be easily detected from the four switches connected to different power sources and hence the four inputs signals are connected to

the plc. If any of the four sources (solar, inverter, mains and generator), back up would be provided automatically provided from the other sources and the load is shared [3]. The need here is to design a sophisticated Transfer Switching system that can take renewable energy source (solar energy) into consideration and two generators that will be shifting from one to another after every six hours during state of redundancy from other sources. Utility is given the top priority followed by solar and then finally generators. When the power is restored in any of the prioritised sources, then the working generator would be instantly shorted down and the load is transferred from that generator to the existing load based on the priority stated previously.

2 LITERATURE REVIEW

In [4], an ATS with an enhanced design including both software and hardware modules were discussed. The generator is controlled and monitored from a remotely located computer system which can as well supervise other parameters and generator's on and off.

In [5], the ATS includes a digital multimeter using microcontroller (PIC16F877A), and Liquid Crystal Display was also used to display A.C current and voltage.

In [6], a simple changeover was designed to automatically transfer the load from utility energy to standby generator

whenever there is power outage. Microcontroller was not used in this design.

In [7], various tasks such as programming crank timer, warm up timer and mains stability switch were accomplished by means of microcontroller, and a circuit for overvoltage protection using comparator, 555 timer IC for the delay needed, were also included.

In [3], an automatic switching system designed to be multi source was implemented where the transfer of load to any source (namely solar, mains, wind and generator) is based on priority such that if any one of the sources fails, then the load would be shifted to the source next to it.

3 WORKING PRINCIPLE

The system constitutes of four sensor (which is a 5V power supply) from the respective sources namely; utility, solar, generator1 and generator2. If utility is available, it is given the top priority, and then utility relay signal would be sent from the microcontroller through the relay driver to connect load. If the mains source is absent, then solar source would automatically be connected while all other sources are deactivated and the system is busy checking for the return of the mains supply. In the absence of solar and utility source, generator1 would be started and allowed to settle for an overall delay of approximately 20s, it will then be connected to the load for 6H while checking for availability of mains or solar source. If the time scheduled for the operation of the generator1 is exhausted without having the other sources' return, then it would be disconnected and switched off while generator 2 would pick up and is connected to the load within a time delay of 20s, it will keep up working and checking for the return of other sources until 6H elapsed, if before the end of the time, there is return of power from either utility or solar, the generator2 would be disconnected and switched off while the load is transferred to the existing source, otherwise generator 1 will take over from generator2. This cycle will keep on repeating as long as the microcontroller is active. The system is made in such a way that if generator1 is working, generator 2 will never come up and vice versa.

The block diagram and flow chart of the overall system are shown in figure 1 and figure 3 respectively. Figure 2 provides the overall circuit simulation.

The Table 1 below shows the various conditions that exist and the corresponding output signals, where 0 stands for no input or output, 1 stands for there is input or output and x stands for don't care condition.

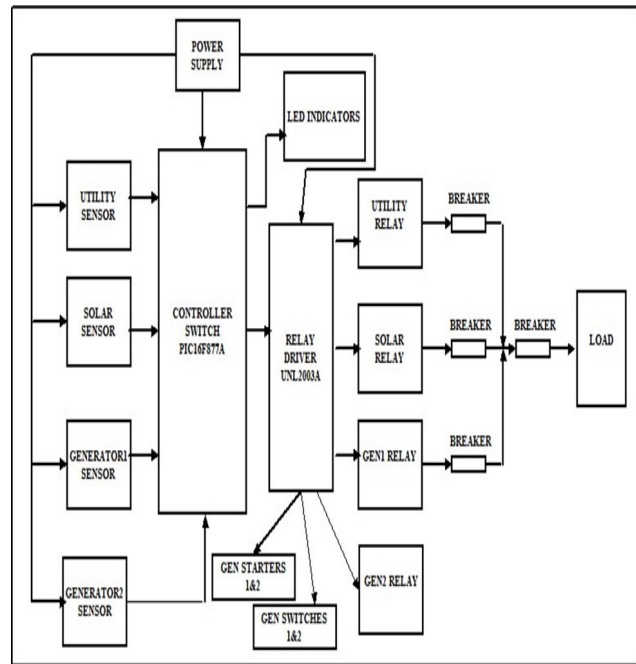

Figure 1: Block Diagram

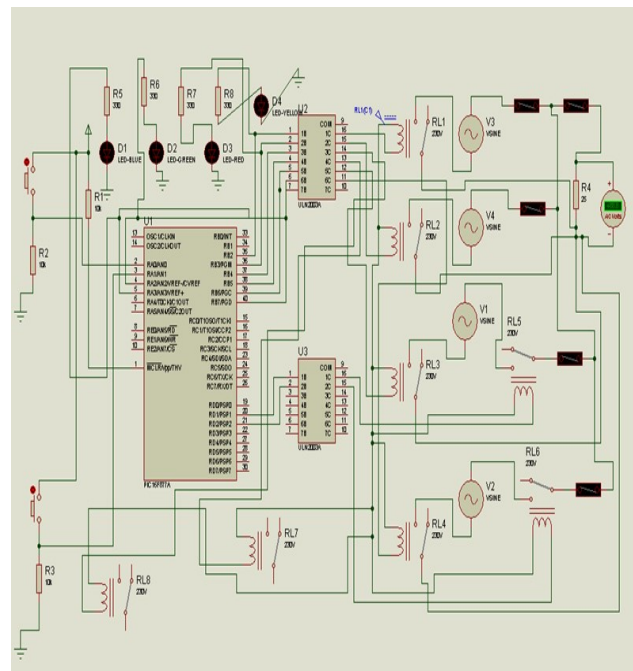

Figure 2: Simulation Circuit

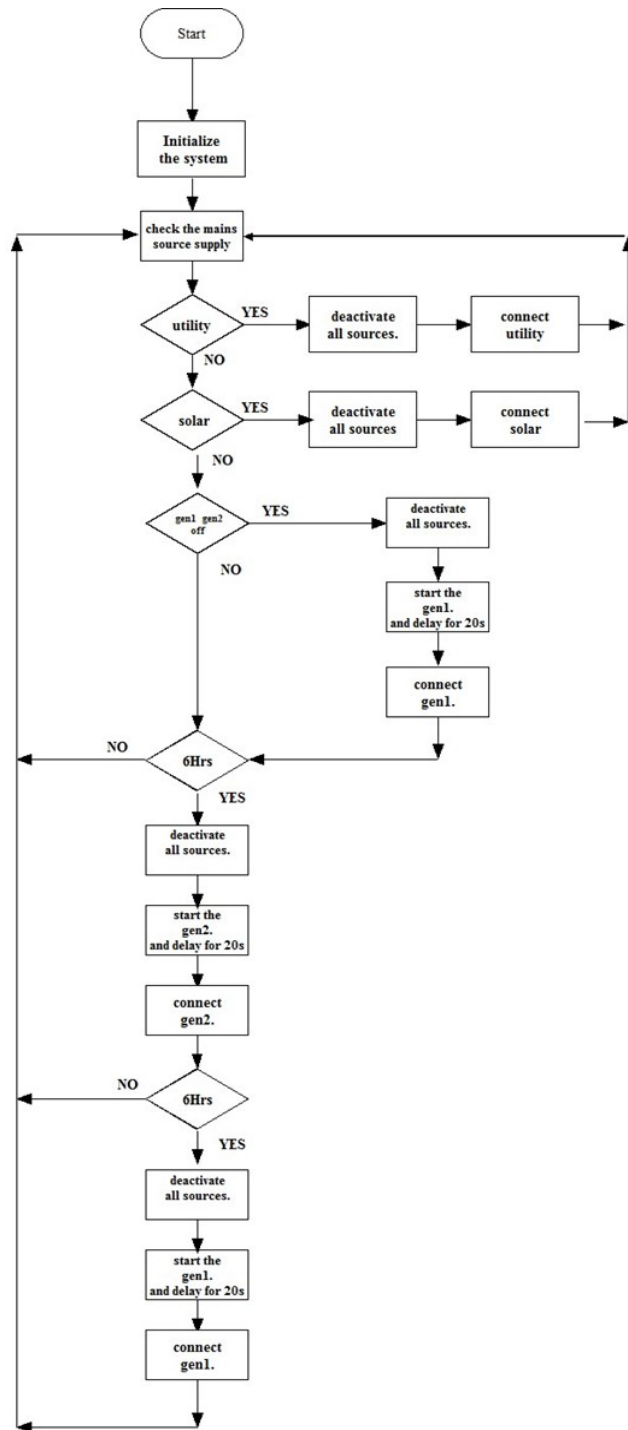

Figure 3: Flow Chart

Table 1: Proposed Power Selection Table

UTILITY SOURCE	INPUT			OUTPUT			
	SOLAR SOURCE	GENERATOR 1 SOURCE FIRST 6 HOURS	GENERATOR 2 SOURCE NEXT 6 HOURS	UTILITY SIGNAL	SOLAR SIGNAL	GENERATOR 1 SIGNAL	GENERATOR 2 SIGNAL
1	x	x	x	1	0	0	0
0	1	x	x	0	1	0	0
0	0	1	x	0	0	1	0
0	0	x	1	0	0	0	1
0	0	0	0	0	0	0	0

4 RESULT AND DISCUSSION

The result obtained from the simulation is summarised in Table 2 below where 0 stands for presence of power while 1 stands for absence of power, and it shows that utility is given the highest priority because whenever the utility source is available, it will be selected regardless of whichever source is present (from row 9 to 16). The table also shows that solar is given the next priority after utility (from row 5 to 8), then followed by generator1 which operates for six hours and then generator2 takes over, it was observed from the simulation that exchange of operation is repeated for every six hours between the two generators. If it happened that during the exchange period, the two generators are working simultaneously due possibly faulty relays, the system failed to switch one of them off, priority is given to generator 1 while keeping generator 2 disconnected. If more than one source are still giving out power, then the external circuit breakers or fuses (either between the sources or between the sources and the load) instantly disconnect the sources from each other or from the load until maintenance is carried out.

Table2: Power Selection Table

SERIAL NUM-BER	INPUT				OUTPUT			
	UTILITY SOURCE	SOLAR SOURCE	GENERATOR1 SOURCE FIRST 6 HOURS	GENERATOR2 SOURCE NEXT 6 HOURS	UTILITY SIGNAL	SOLAR SIGNAL	GENERATOR1 SIGNAL	GENERATOR2 SIGNAL
1	0	0	0	0	0	0	1	0
2	0	0	0	1	0	0	0	1
3	0	0	1	0	0	0	1	0
4	0	0	1	1	0	0	1	0
5	0	1	0	0	0	1	0	0
6	0	1	0	1	0	1	0	0
7	0	1	1	0	0	1	0	0
8	0	1	1	1	0	1	0	0
9	1	0	0	0	1	0	0	0
10	1	0	0	1	1	0	0	0
11	1	0	1	0	1	0	0	0
12	1	0	1	1	1	0	0	0
13	1	1	0	0	1	0	0	0
14	1	1	0	1	1	0	0	0
15	1	1	1	0	1	0	0	0
16	1	1	1	1	1	0	0	0

5 CONCLUSION

The system was simulated and works satisfactorily as expected, it would be of high importance if it would be used where interruption of power is a critical issue such as banks, industries and hospitals. It is designed to have a minimum delay of 1s unless during transition to generators where the delay is up to 20s for generators' stability.

6 FUTURE WORK

A backup supply should be incorporated to compensate for the delay of 20s and also a comparator design approach should be used to detect under and overvoltage.

REFERENCES

[1] Kolo, J. G. (2007). Design and Construction of an Automatic Power Changeover Switch. *AU Journal of Technical Report*, 11(2), (pp. 1-6).

[2] Azeem, M. Q., Habib-Ur-Rehman, Ahmed, S., & Khattak, A. (2017). Design and analysis of switching in automatic transfer switch for load transfer. In *ICOSST 2016 - 2016 International Conference on Open Source Systems and Tegnies, Proceedings* (pp. 129 - 134).

[3] Shinde S.P, Mohite U.V, Alatekar S.S, Chavan V.S, Patil G.B & Waware S. Y. (2017), Priority Based Automatic Multi Source Switching Using Plc, *International Journal Of Research Publications In Engineering And*

Technology, (pp. 104 – 107)

[4] Adoghe, A. U., and I. A. Odigwe. (2009). "Automatic Transfer and Controller System for Standby Power Generator." *Advanced Materials Research* 62. (pp. 187-193).

[5] Agbetuyi, A. F., Adewale, A. A., Ogunluyi, J. O., & Ogunleye, D. S (2011). "Design and Construction of an Automatic Transfer Switch for a Single Phase Power Generator." Department of Electrical and Information Engineering, Ota, Nigeria.

[6] Ezema, L. S., B. U. Peter, and O. O. Harris (2012). "De-sign of automatic change over switch with generator control mechanism." *Academic Research International*, 3(3), (pp. 125 – 130)

[7] Olatomiwa Lanre and Rasheed Olufadi (2014). "De-sign and development of a low cost automatic transfer switch (ATS) with an over-voltage protection." *Journal of Multidisciplinary Engineering Science and Technology*, 1(4), (pp. 190 - 196).

Removal of Furfural from Lignocellulosic Hydrolysates for Improved Bioethanol Production: Current Trends and Challenges

Chidinma O. Onubogu¹, Zainul A. Zakaria^{1,2} and Umi A. Asli^{1,3*}

¹ Faculty of Chemical and Energy Engineering, Universiti Teknologi Malaysia, 81310 Johor Bahru, Johor Malaysia.

²Institute of Bioproduct Development, Universiti Teknologi Malaysia, 81310 Johor Bahru, Johor, Malaysia.

³Innovation Center in Agritechology for Advanced Bioprocessing, UTM Pagoh Research Center, 84600 Pagoh, Johor, Malaysia.

*umiaisah@cheme.utm.my

Abstract— Over the years, tremendous research has been ongoing to find cost effective ways to produce bioethanol on a large scale as it serves as a form of renewable energy. Second-generation materials also referred to as lignocellulosic materials, form inedible feedstocks for bioethanol production as they are composed of agricultural residues such as oil palm empty fruit bunch, rice straw, corn straw, municipal solid waste, waste paper and forest residues. However, the use of acid for pretreatment or hydrolysis of lignocellulosic biomass leads to the formation of inhibitors that affect the fermentation process and subsequently reduce bioethanol yield. In this paper, an overview of the various methods that have been employed in the removal of furfural, a major inhibitor is discussed. Current trends and challenges faced have also been identified. An effective and low-cost method for removal of one of the major fermentation inhibitors is also presented.

Keyword— Bioethanol, Fermentation inhibitors, Lignocellulosic biomass, Palm empty fruit bunch (EFB)

1 INTRODUCTION

In order to cope with increasing energy demands and reduce emission of greenhouse gases, research has been ongoing to discover alternative sources of energy that are renewable so as to reduce dependence on fossil fuel. Global focus on the use of bioethanol as a renewable alternative has increased greatly in recent years [1]. Currently, bioethanol is being used to power automobiles as additives or extender because of its high-octane rating. For example, E85 is a blended fuel of 85% bioethanol and 15% gasoline [2]. The world's largest producer and consumer of ethanol is the United States, followed by Brazil [3]. In 2015, the US alone accounted for 15 billion gallons of the total production. Together, the U.S. and Brazil produce 85% of the world's ethanol [4]. A large amount of U.S. ethanol is produced from corn, while Brazil primarily uses sugar. Figure 1.1 shows global ethanol production by country or region, from 2007 to 2015. Global production peaked in 2015 after a dip in 2012 and 2013. Production of bioethanol can be done using various feedstocks. These feedstocks can be divided into three categories: sucrose-rich crops, starch rich crops and lignocellulosic materials [5]. Sucrose-rich crops and starch-rich crops include food resources such as corn and sugarcane and can be further classified as first-generation materials. However, due to the growing concern that the use of these materials would affect food supply, focus was shifted to the use of lignocellulosic materials as they form inedible feedstocks. Lignocellulosic materials are classified as second-generation materials [6] and can be categorized based on type of resource into four groups: crop residue resources, waste paper, municipal solid waste and forest residues [5]. Presently, attention is on the production of bioethanol from highly abundant crop residues such as oil palm empty fruit bunch, rice straw, corn straw, wheat straw etc. as it avoids the existing competition of food versus fuel caused by food-based

feedstocks [7]. This paper gives an overview of the various methods that have been used for removal of furfural from lignocellulosic biomass and presents the use of activated carbon as a cheaper and more effective method.

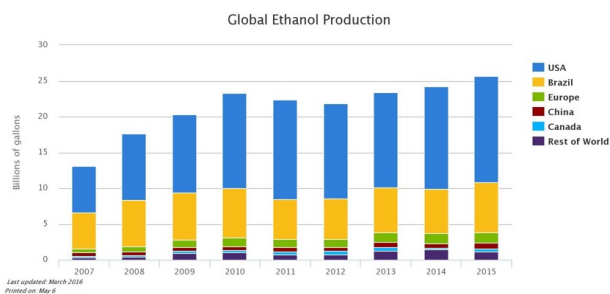

Figure 1.1 Global Ethanol Production by Country [1]

The rest of this paper is organised as follows. In Section 2, the current trends in bioethanol production from lignocellulosic biomass is discussed. Section 3 discusses the open issues in fermentation inhibitors. Section 4 presents the future direction and Section 5 concludes the paper.

2 CURRENT TRENDS IN BIOETHANOL PRODUCTION FROM LIGNOCELLULOSIC BIOMASS

In recent times, the focus has been on the use of lignocellulosic biomass for bioethanol production as it does not interfere with food availability and because it is the largest renewable resource in the world. About 442 liters of bioethanol is produced from lignocellulosic biomass per year [8]. The basic components of all lignocellulosic materials are: cellulose (30-50%), hemicellulose (15-35%), and lignin (10-20%) [9, 10]. The two ways of converting lignocellu-

losic biomass into bioethanol are: biochemical conversion and thermochemical conversion [11]. They both have to do with breaking lignocellulosic biomass' resistant cell wall structure into its basic components; cellulose, lignin and hemicellulose, which undergo hydrolysis to form sugars and are eventually converted into bioethanol then purified [11].

Nevertheless, the two conversion methods have different procedures. Thermochemical conversion has to do with gasification of the biomass at 800°C along with a catalytic reaction. The use of a very high temperature ensures the conversion of the biomass into synthesis gas (syngas) like carbon monoxide, hydrogen and carbon dioxide. The syngas formed can be used to form ethanol and water by microorganisms, using catalysts. Distillation can then be used to separate them [12].

Biochemical conversion begins with the pretreatment step which could be physical, thermo-chemical or biological pretreatment [13]. The purpose of pretreatment is to break the recalcitrant structure of the material and provide a larger surface area for easy accessibility of the cellulose to cellulase [13]. After pretreatment, cellulosic materials undergo enzymatic or acid hydrolysis (cellulolysis) and hemicellulose conversion (saccharification) to form monomeric free sugars. The next step involves biological fermentation of sugars into ethanol and final purification using distillation [12]. The most recalcitrant material among the components of cell walls; lignin, undergoes combustion to produce electricity and heat [14]. The biochemical conversion process is made up of four-unit operations: pretreatment, hydrolysis, fermentation and distillation [15] and it is the most commonly used technique for production of bioethanol.

Cellulose, the main constituent of plant biomass, is a structural polysaccharide with glycosidic linkages and additional hydrogen bonding which makes it rigid and hard to break. During hydrolysis, cellulose is broken down into its component sugar molecules [16]. The product formed is a six-carbon sugar called glucose. The process is called saccharification. Hemicellulose is a second major constituent made up of five-carbon (pentoses) and six-carbon (hexoses) sugars. Hemicellulose comprises of xylose and arabinose (five-carbon sugars), and galactose, glucose and mannose (six-carbon sugars). Due to the amorphous nature of hemicellulose, they are more easily broken down during hydrolysis compared to cellulose [17]. The main five-carbon sugar gotten from hardwood and agricultural residues hemicellulose is xylose while mannose is gotten from the hemicellulose of softwood [18].

3 INHIBITORS

Pretreatment of lignocellulosic materials can lead to the formation of various inhibitory substances that slow down the action of fermenting microorganisms. These substances have different sources and are broadly divided into three, namely: furan derivatives, weak acids and phenolic compounds [19]. Lately, a lot of research has been carried out to determine the effect of a single inhibitor on the growth and fermentation of yeast [20]. Results have shown that the presence of these inhibitors in the fermentation process can reduce the specific growth rate [21], re-

duce biomass production [21] and also reduce specific and volumetric productivity of ethanol [22].

When methods like acid pretreatment, acid hydrolysis and sulfite pulping are used for the hydrolysis of hemicelluloses, the pentose and uronic acids formed go through dehydration, leading to the generation of 2-furaldehyde (furfural). The six-carbon sugars that are also formed from hemicelluloses hydrolysis go through dehydration to form 5-hydroxymethyl-2-furaldehyde also referred to as HMF [23]. Furfural and HMF are the furan derivatives. HMF can undergo further degradation to form formic and levulinic acids when exposed to conditions such as high temperature and acid concentration, and extended time of reaction [24]. Another acid formed due to hydrolysis of hemicelluloses' acetyl group during acidic treatment of biomass is acetic acid. Levulinic acid, formic acid and acetic acid are the weak acids formed. Phenolic compounds are formed when the β -O-4 ether and acid-labile linkages in lignin are split during acidic treatments. When the concentration of these compounds in the biomass hydrolysate is above threshold concentration, they affect the fermentation process and subsequently the ethanol yield. Therefore, for effective fermentation to take place, the removal of these inhibitors from biomass hydrolysate is necessary.

Based on previous studies, furfural has been identified as a major inhibitor found in most hydrolysates of lignocellulosic biomass [25]. Furfural inhibits growth and alcohol production by *Saccharomyces cerevisiae*, which is commonly used during the fermentation process. It was suggested that the inhibition of glycolysis and reduced ethanol production were caused by the action of furfural on important glycolytic enzymes such as triosephosphate dehydrogenase and alcohol dehydrogenase [26]. Therefore, there has been more focus on the removal of furfural leading to improved bioethanol production.

Various processes such as membrane separation, distillation, over-liming, nanofiltration, solvent extraction, adsorption etc. have been applied for the removal of furfural from a solution. Azeotropic distillation at a temperature of 180-200°C and a pressure of 8-10 atm was used to remove furfural from an aqueous solution. During distillation of aqueous solution of furfural at atmospheric pressure, a heteroazeotrope containing 35% by weight of furfural is produced. This makes it difficult to fully remove furfural by distillation as 84.1% by weight of furfural is contained in the organic phase and 18.4% is in the water phase when condensation occurs [27]. The use of organic solvents such as toluene, methyl isobutyl ketone (MIBK) and isobutyl acetate (IBA) for extraction of furfural from aqueous solution has also been studied [28]. In as much as the use of toluene was less expensive compared to MIBK and IBA, and there was less solvent loss during the extraction process, toluene was found to be more toxic than the other two solvents. The use of supercritical carbon dioxide for extraction of furfural at high temperature (298-333K) and high pressure (80-340 bar) has also been studied [29]. It was noticed that with decrease in temperature and increase in pressure, the solubility of furfural increased. The application of organic solvent extraction on an industrial scale is limited by the large amount of solvent that will be used.

The use of flat sheet hydrophobic polyurethane urea

membranes for pervaporative separation of furfural/water mixtures was investigated and the process was seen to be diffusion-limited [30]. The membranes showed selectivity for furfural as the separation factor between furfural and water was 638 and the permeate flux was 44.7g/m²h. With an increase in the feed temperature and the feed's furfural content, there was a corresponding increase in the partial flux of furfural. Although the polyurethane membranes were seen as appropriate for the separation process, the pretreated biomass consists of various chemicals that could cause membrane fouling if the process were to be applied industrially. Nanofiltration was also applied for removal of furfural [31]. It was found that increasing the operating temperature tended to increase the pore size of the membrane, causing a decrease in retention of sugars.

Different adsorbents such as zeolite, polymeric resins, activated carbon etc have been used for the removal of furfural from lignocellulose hydrolysates by adsorption. The use of Amberlite polymeric resin XAD-4 (polystyrene-divinylbenzene copolymer bead) for adsorption of furfural from water was investigated [32]. At an equilibrium solution concentration of 2g/l of furfural, 90mg of furfural was adsorbed per gram of the adsorbent (XAD-4). The results obtained using XAD-7 (methacrylic ester bead) as adsorbent were similar to that of XAD-4. Different types of zeolites have been studied as adsorbents of HMF, furfural, and xylose [33]. The use of hydrophobic zeolites with the same pore size but different Si/Al ratios for adsorption, has been examined. The results showed the same adsorption isotherms for these zeolites as they selectively adsorbed the inhibitors at 298K. The results also established that zeolites containing large amounts of silica perform more efficiently in the removal of furfural and HMF.

Application of coconut-based commercial activated carbon for furfural removal was investigated [2]. The equilibrium adsorption was attained in six hours and the adsorption kinetics followed the pseudo-second order rate. The use of two types of activated carbon (commercial activated carbon and polymer-derived activated carbon) for adsorption of furfural from an aqueous solution was studied [3]. The results showed effective removal of furfural from the biomass hydrolysate, that led to efficient fermentation. However, the use of adsorption for removal of furfural sometimes leads to removal of some of the fermentable sugars and might affect final ethanol yield [2].

4 FUTURE DIRECTION

Current technologies used for production of bioethanol from lignocellulosic biomass are quite expensive and the high cost of the hydrolysis process and low yield are major problems [35]. For the biomass-to- bioethanol conversion process to be economical, all the sugars present in the cellulose and hemicellulose must be efficiently converted as the feedstock accounts for greater than 40% of all process costs [35-37]. The use of dilute acid for pre-treatment and hydrolysis has been well established for low cost production of fermentable sugars because it promotes the effective hydrolysis of hemicelluloses [38]. However, the major disadvantage of using dilute acid for pre-treatment is that it leads to the formation of different compounds (e.g. furfural, hydroxymethyl furfural, phenolic compounds etc.)

which act as fermentation inhibitors.

To make the process economically viable and attractive to industries, it must have low production cost and high yield. Activated carbon is the most widely used and cost-effective sorbent in industrial application [39] due to its porous structure and huge internal surface area for adsorption. Hence, recent investigations have been focused on the use of activated carbon for adsorption of furfural from lignocellulosic hydrolysates by varying various experimental parameters such as temperature, contact time, pH and adsorbent dose [40, 41].

5 CONCLUSION

In this paper, a review of the removal of furfural from lignocellulosic hydrolysates for improved bioethanol production has been presented. The various methods that have been employed in the removal of some of inhibitors which are formed from the use of acid for pretreatment and hydrolysis was discussed and future direction identified. From our review, the use of activated carbon for adsorption of furfural from lignocellulosic hydrolysates will continue to attract more research interest due to its economical benefits.

REFERENCES

- [1] Nigam, P.S., and Singh, A.: 'Production of liquid biofuels from renewable resources', *Progress in energy and combustion science*, 2011, 37, (1), pp. 52-68
- [2] Zhang, K., Agrawal, M., Harper, J., Chen, R., and Koros, W.J.: 'Removal of the fermentation inhibitor, furfural, using activated carbon in cellulosic-ethanol production', *Industrial & Engineering Chemistry Research*, 2011, 50, (24), pp. 14055-14060
- [3] Balat, M., and Balat, H.: 'Recent trends in global production and utilization of bio-ethanol fuel', *Applied energy*, 2009, 86, (11), pp. 2273-2282
- [4] Tyner, W.E.: 'US ethanol policy—Possibilities for the future', 2015
- [5] Balat, M.: 'Production of bioethanol from lignocellulosic materials via the biochemical pathway: a review', *Energy conversion and management*, 2011, 52, (2), pp. 858-875
- [6] Naik, S.N., Goud, V.V., Rout, P.K., and Dalai, A.K.: 'Production of first and second generation biofuels: a comprehensive review', *Renewable and Sustainable Energy Reviews*, 2010, 14, (2), pp. 578-597
- [7] Kim, S., and Dale, B.E.: 'Global potential bioethanol production from wasted crops and crop residues', *Biomass and Bioenergy*, 2004, 26, (4), pp. 361-375
- [8] Bohlmann, G.M.: 'Process economic considerations for production of ethanol from biomass feedstocks', *Industrial Biotechnology*, 2006, 2, (1), pp. 14-20
- [9] Mielenz, J.R.: 'Ethanol production from biomass: technology and commercialization status', *Current opinion in microbiology*, 2001, 4, (3), pp. 324-329
- [10] Girio, F.M., Fonseca, C., Carvalheiro, F., Duarte, L.C., Marques, S., and Bogel-Lukasik, R.: 'Hemicelluloses for fuel ethanol: a review', *Bioresource technology*, 2010, 101, (13), pp. 4775-4800

- [11] Demirbas, A.: 'Progress and recent trends in biofuels', *Progress in energy and combustion science*, 2007, 33, (1), pp. 1-18
- [12] Mu, D., Seager, T., Rao, P.S., and Zhao, F.: 'Comparative life cycle assessment of lignocellulosic ethanol production: biochemical versus thermochemical conversion', *Environmental management*, 2010, 46, (4), pp. 565-578
- [13] Yang, B., and Wyman, C.E.: 'Pretreatment: the key to unlocking low-cost cellulosic ethanol', *Biofuels, Bioproducts and Biorefining*, 2008, 2, (1), pp. 26-40
- [14] Gamage, J., Lam, H., and Zhang, Z.: 'Bioethanol production from lignocellulosic biomass, a review', *Journal of Biobased Materials and Bioenergy*, 2010, 4, (1), pp. 3-11
- [15] Sanchez, O.J., and Cardona, C.A.: 'Trends in biotechnological production of fuel ethanol from different feedstocks', *Bioresource technology*, 2008, 99, (13), pp. 5270-5295
- [16] Hamelinck, C.N., Van Hooijdonk, G., and Faaij, A.P.: 'Ethanol from lignocellulosic biomass: techno-economic performance in short-, middle-and long-term', *Biomass and bioenergy*, 2005, 28, (4), pp. 384-410
- [17] Yang, H., Yan, R., Chen, H., Lee, D.H., and Zheng, C.: 'Characteristics of hemicellulose, cellulose and lignin pyrolysis', *Fuel*, 2007, 86, (12), pp. 1781-1788
- [18] Taherzadeh, M.J., and Karimi, K.: 'Pretreatment of lignocellulosic wastes to improve ethanol and biogas production: a review', *International journal of molecular sciences*, 2008, 9, (9), pp. 1621-1651
- [19] Palmqvist, E., and Hahn-Hägerdal, B.: 'Fermentation of lignocellulosic hydrolysates. II: inhibitors and mechanisms of inhibition', *Bioresource technology*, 2000, 74, (1), pp. 25-33
- [20] Keating, J.D., Panganiban, C., and Mansfield, S.D.: 'Tolerance and adaptation of ethanologenic yeasts to lignocellulosic inhibitory compounds', *Biotechnology and bioengineering*, 2006, 93, (6), pp. 1196-1206
- [21] Oliva, J.M., Sáez, F., Ballesteros, I., González, A., Negro, M.J., Manzanares, P., and Ballesteros, M.: 'Effect of lignocellulosic degradation compounds from steam explosion pretreatment on ethanol fermentation by thermotolerant yeast *Kluyveromyces marxianus*', *Applied Biochemistry and Biotechnology*, 2003, 105, (1-3), pp. 141
- [22] Larsson, S., Quintana-Sáinz, A., Reimann, A., Nilvebrant, N.-O., and Jönsson, L.J.: 'Influence of lignocellulose-derived aromatic compounds on oxygen-limited growth and ethanolic fermentation by *Saccharomyces cerevisiae*', *Applied Biochemistry and Biotechnology*, 2000, 84, (1), pp. 617-632
- [23] Jönsson, L.J., and Martín, C.: 'Pretreatment of lignocellulose: formation of inhibitory by-products and strategies for minimizing their effects', *Bioresource technology*, 2016, 199, pp. 103-112
- [24] Fengel, D., and Wegener, G.: 'Wood: chemistry, ultrastructure, reactions' (Walter de Gruyter, 1983)
- [25] Heer, D., and Sauer, U.: 'Identification of furfural as a key toxin in lignocellulosic hydrolysates and evolution of a tolerant yeast strain', *Microbial biotechnology*, 2008, 1, (6), pp. 497-506
- [26] Banerjee, N., Bhatnagar, R., and Viswanathan, L.: 'Inhibition of glycolysis by furfural in *Saccharomyces cerevisiae*', *Applied Microbiology and Biotechnology*, 1981, 11, (4), pp. 226-228
- [27] Buell, C., and Boatright, R.: 'Furfural Extractive Distillation', *Industrial & Engineering Chemistry*, 1947, 39, (6), pp. 695-705
- [28] Zautsen, R., Maugeri-Filho, F., Vaz-Rossell, C., Straathof, A., Van der Wielen, L., and de Bont, J.: 'Liquid-liquid extraction of fermentation inhibiting compounds in lignocellulose hydrolysate', *Biotechnology and bioengineering*, 2009, 102, (5), pp. 1354-1360
- [29] Sangarunlert, W., Piumsomboon, P., and Ngamprasertsith, S.: 'Furfural production by acid hydrolysis and supercritical carbon dioxide extraction from rice husk', *Korean Journal of Chemical Engineering*, 2007, 24, (6), pp. 936-941
- [30] Ghosh, U.K., Pradhan, N.C., and Adhikari, B.: 'Separation of furfural from aqueous solution by pervaporation using HTPB-based hydrophobic polyurethaneurea membranes', *Desalination*, 2007, 208, (1-3), pp. 146-158
- [31] Weng, Y.-H., Wei, H.-J., Tsai, T.-Y., Lin, T.-H., Wei, T.-Y., Guo, G.-L., and Huang, C.-P.: 'Separation of furans and carboxylic acids from sugars in dilute acid rice straw hydrolyzates by nanofiltration', *Bioresource technology*, 2010, 101, (13), pp. 4889-4894
- [32] Weil, J.R., Dien, B., Bothast, R., Hendrickson, R., Mosier, N.S., and Ladisch, M.R.: 'Removal of fermentation inhibitors formed during pretreatment of biomass by polymeric adsorbents', *Industrial & engineering chemistry research*, 2002, 41, (24), pp. 6132-6138
- [33] Ranjan, R., Thust, S., Gounaris, C.E., Woo, M., Floudas, C.A., von Keitz, M., Valentas, K.J., Wei, J., and Tsapatsis, M.: 'Adsorption of fermentation inhibitors from lignocellulosic biomass hydrolyzates for improved ethanol yield and value-added product recovery', *Microporous and Mesoporous Materials*, 2009, 122, (1), pp. 143-148
- [34] Sahu, A.K., Srivastava, V.C., Mall, I.D., and Lataye, D.H.: 'Adsorption of furfural from aqueous solution onto activated carbon: Kinetic, equilibrium and thermodynamic study', *Separation Science and Technology*, 2008, 43, (5), pp. 1239-1259
- [35] Sun, Y., and Cheng, J.: 'Hydrolysis of lignocellulosic materials for ethanol production: a review', *Bioresource technology*, 2002, 83, (1), pp. 1-11
- [36] Govindaswamy, S., and Vane, L.M.: 'Kinetics of growth and ethanol production on different carbon substrates using genetically engineered xylose-fermenting yeast', *Bioresource technology*, 2007, 98, (3), pp. 677-685
- [37] Mohagheghi, A., Evans, K., Chou, Y.-C., and Zhang, M.: 'Cofermmentation of glucose, xylose, and arabinose by genomic DNA-integrated xylose/arabinose fermenting strain of *Zymomonas mobilis* AX101', *Applied biochemistry and biotechnology*, 2002, 98, (1-9), pp. 885
- [38] Zhao, X., Zhang, L., and Liu, D.: 'Biomass recalcitrance. Part I: the chemical compositions and physical structures affecting the enzymatic hydrolysis of lignocellulose', *Biofuels, Bioproducts and Biorefining*, 2012, 6, (4), pp. 465-482
- [39] Zhang, F., Rodriguez, S., and Keasling, J.D.: 'Metabolic engineering of microbial pathways for advanced biofuels production', *Current opinion in biotechnology*, 2011, 22, (6), pp. 775-783

-
- [40] Cuevas, M., Quero, S.M., Hodaifa, G., López, A.J.M., and Sánchez, S.: 'Furfural removal from liquid effluents by adsorption onto commercial activated carbon in a batch heterogeneous reactor', *Ecological Engineering*, 2014, 68, pp. 241-250
- [41] Ma, H., Ji, X., Tian, Z., Fang, G., and Yang, G.: 'Adsorption Removal of Inhibiting Compounds by Modified Activated Carbon', *Journal of Energy and Natural Resources*, 2017, 6, (2), pp. 24

Coordinated Application for Saving, Time, Energy and Money in a Smart-Home

Olakunle Elijah^{1*}, Tharek Abdul Rahman¹, Ho Chun yeen¹, Suhanya Jayaprakasam¹, Igbafe Orikumhi² and Abdul Hadi Hamid³

¹Wireless Communication Center, University of Teknologi Malaysia, Malaysia

²Department of Electronics Engineering, 5G/Unmanned Vehicle Research Center (ITRC), Hanyang University, Seoul, Korea

³Advanced Telecommunication Technology Center, University of Teknologi Malaysia

* elij_olak@yahoo.com

Abstract—In this paper, we present a system for coordinating applications, saving, time, energy and money (CASTEM) in a smart-home (SH). The system aims to address the issues of energy optimization, convenience, automation, security and safety, and entertainment in a SH. To demonstrate the application of CASTEM, a prototype has been developed which consist of a gateway, SH model, internet of things (IoT) and the preliminary results are presented. It is expected that the use of CASTEM will enhance the standard of living conditions within a SH, reduce energy wastage, provide real-time analysis and help save money.

Keyword— Automation; energy optimization; Internet of Things (IoT); smart home

1 INTRODUCTION

The emergence of internet of things (IoT), ubiquitous connective, the increase in use of smart mobile devices, have paved the way for adoption of smart home (SH) in recent time. This is motivated by the increase of an ageing population, the need to enhance the quality of life within the home, the need to reduce cost, and need to promote safety within the home among many others. The concept of SH can be defined as a residence equipped with computing and information technology which anticipates and responds to the needs of the occupants, working to promote their comfort, convenience, security and entertainment through the management of technology within the home and connections to the world beyond.

There are several use cases of SH that have been discussed in the literature. Examples of such use cases include the following: monitoring of daily activities within the home [1], energy conservation and optimization [2], [3], health care [1], [4], security management [5], and home automation [6]. Unlike the existing work which focuses on different applications in a smart home, in this paper, we propose a system for coordinating applications, savings, time, energy and money (CASTEM). The system is designed to provide convenience, coordinate the different applications in a SH, optimize energy consumption, promote security and safety of the SH and ultimately help save money. In this paper, the term smart-home also refers to a smart building. The rest of this paper is structured as follows. In Section 2, the key features of CASTEM are presented. Section 3 covers the methodology and setup of CASTEM. Section 4 discusses the preliminary results and Section 5 concludes the paper.

2 KEY FEATURES OF CASTEM

In this section, we discuss the key features that CASTEM

intends to address in a SH. They include coordinating applications, savings, time, energy and money.

2.1 Coordinating Applications

Thanks to the introduction of smart devices like the Google home and Amazon echo [7], which are voice activated for interaction with services through intelligent personal assistants. Others include smart electrical appliances such smart kettle, rice cooker, purifier, LED bulbs, lightings and locks. These smart devices can be configured using smart portable devices via Wi-Fi, Bluetooth or other forms of communication technologies. Most of these smart devices are limited to home automation via preconfigured settings or scheduling without considering energy analysis and operational efficiency. To this end, CASTEM aims to enable coordinated application of smart devices which takes into consideration operational efficiency, energy optimization, activities and real-time analysis within a SH. This can be achieved by using scheduling algorithm, use of machine learning to learn the pattern of operation and activities within the SH.

2.2 Savings

The CASTEM aims to enable savings within a SH by providing early notification in emergency situations such as fire hazard, gas leakages, and electrical overloads. Such notification can activate safety modes within the SH. In addition, the ability to reduce energy wastages by using smart sensors to detect and control electrical appliance will lead to a reduction of electricity bills. These features will enable saving of lives, money and property within the SH. Furthermore, homeowners can specify the amount of energy bill to be used within a period and the smart appliances within the home can be optimized based on environmental parameters, critical task, peak and off-peak charges.

2.3 Time

Time remains an essential part of our lives. There several

ways SH can help save our time such as providing control of all appliances within the home and remotely from our smart devices. Appliances can be pre-scheduling and remotely automated without the need to operate them directly.

2.4 Money

The current challenge of adopting SH is the initial cost of installation, especially in existing buildings. The ability to provide a return on investment (ROI) over a short period can be a motivating factor for existing homes to adopt the SH technology. Although it is expected that the cost of setting up a SH over time will get cheaper, CASTEM is expected to deliver ROI within a very short time for users. CASTEM algorithms and optimization techniques take into consideration several factors such as environmental conditions, peak and off-peak tariff, human activity within the home to help drive energy bills down while maintaining convenience. In addition, users can specify the amount of energy monthly consumption and cost to be used

2.5 Energy

The increase in connected devices will lead to increase in power consumption within the homes. Although, manufacturers are making appliances which are more power efficient, however, electricity tariffs are still on the increase. Hence, the need to reduce wastages by using different techniques such as scheduling of appliance, on and off lighting using context awareness techniques, control of heating ventilation and air conditioning (HVAC) with environmental factors such as temperature, humidity and intensity of light.

3 METHODOLOGY

The CASTEM consists of four main components which are smart-home model with sensors (rain, temperature, current, motion, gas, humidity, magnetic, light) and actuators (servo motor, buzzer) IoT cloud (Thingspeak), gateway (Raspberry Pi-3) and apps (mobile apps and desktop apps). Figure 1.0 illustrates the system model.

A prototype of the CASTEM was developed using raspberry Pi-3 as the gateway, Thingspeak as IoT cloud, and mobile app was developed using Android studio while the desktop app was developed using MATLAB 2015a. There are four phases used to achieve the aim of CASTEM. They are monitoring, analysis, optimization and prediction phases. The phases are discussed as follows. Figure 1.0: System model for CASTEM

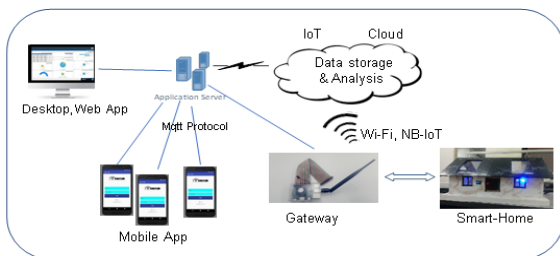

3.1 Analysis

There are several analyses that can be carried out in the SH. These include energy usage analysis, efficiency analysis,

cost analysis, operational analysis, and correlational analysis. For instance, using the Algorithm 1, the energy usage analysis can be carried out by calculating the energy consumption per time in kWh.

Algorithm 1 Energy Calculation (Kwh)

```

1: Initialize StartTime = 0, EndTime = CurrentTime, SamplingTime = 1
   ▷ CurrentTime is a function, giving sampling time is 1s
2: while True do
3:   StarTime = CurrentTime
4:   if StartTime - EndTime ≥ SamplingTime then
5:     for each x ∈ M do
6:       watt = watt + AppliancePower[x]
7:     end for
8:     TotalWatt = TotalWatt + watt
9:     TotalKwh = TotalWatt * samplingTime / 1000 / 3600
   from w to Kwh
10:    watt = 0
11:    EndTime = CurrentTime
12:  end if
13: end while
    
```

3.2 Monitoring

In the SH, real-time monitoring can be carried out and logged to the IoT cloud using sensor nodes. The Algorithm for the monitoring phase is described in Algorithm 2.

Algorithm 2 Monitoring Phase

```

1: Initialize Internet Connection
2: Initialize Sensor Node
3: Initialize StartTime = 0, EndTime = CurrentTime, SendingInterval = 30
   ▷ CurrentTime is a function, giving interval time of sending data to cloud is 30s
4: while True do
5:   StarTime = CurrentTime
6:   if No Internet Connection then
7:     Reconnect to Internet
8:   else if StartTime - EndTime ≥ SendingInterval then
9:     Read Sensor Node
10:    Process data into packet
11:    Send data to cloud
12:    Save data in local server
13:    EndTime = CurrentTime
14:  end if
15: end while
    
```

3.3 Optimization

The optimization phase enables home owners to specify the amount of energy to be consumed for the month. There are different modes that can also be activated such as super saving mode, economy mode and normal mode. The optimization of energy consumption based on maximum cap specified by the home user can be expressed as follows.

$$\begin{aligned}
 & \min_{X_i} \sum_{i=0}^T y_i \\
 & s.t. \sum_{i=0}^T y_i \leq \frac{\gamma}{T}
 \end{aligned} \tag{1}$$

where y_i and X_i is the total cost and on/off, respectively in time slot i and denoted as $y_i = [\bar{C} \square \bar{U} \square \bar{X}] \cdot \bar{R}$. $\bar{C}, \bar{U}, \bar{X}, \bar{R} = [1 \times M]$ and represents critical tasks (must be switched on), user controlled (forced on), binary on/off

and rate of each appliance, respectively. The $T, \frac{\gamma}{T}$ are the total sampling time of usage and maximum cost of energy to be consumed per month in time T .

3.4 Prediction

There are different types of machine learning methods that can be used to predict the amount of power to be consumed and to recognize the activities within the SH. Examples of such prediction models are Bayes belief networks, artificial neural network, sequential minimal optimization and logitBoost [8]. We shall explore the use of Bayes belief networks in our future work, where each group of data collected will be modelled and classified into different observation models. The state models of the devices will be compared with the measured data and based on the comparison, a self-optimizing correction factor can be implemented while providing a prediction of the behavior of each device. The prediction will provide information of possible device behavior and actions that can be taken to achieve the features of CASTEM.

4 RESULTS

In this section, we show the preliminary results of real-time monitoring of the environmental parameters such as; temperature and humidity, operation of lighting points and air condition, power consumption and accumulated power consumption for the SH model.

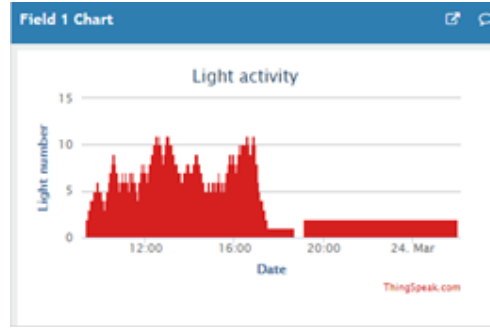

(c)

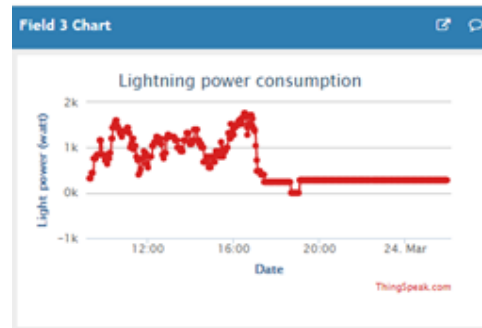

(d)

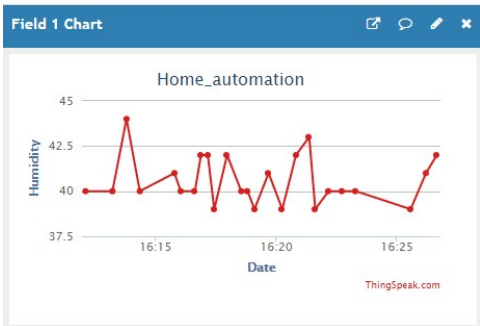

(a)

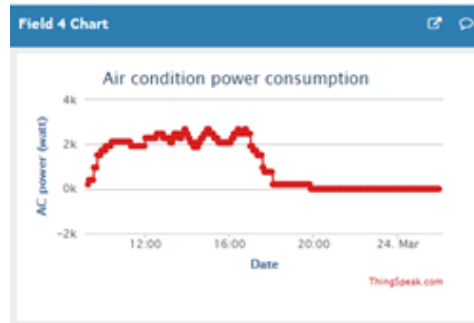

(e)

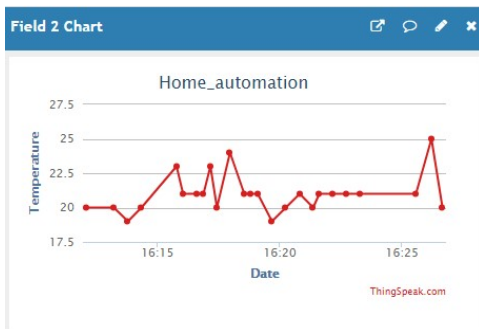

(b)

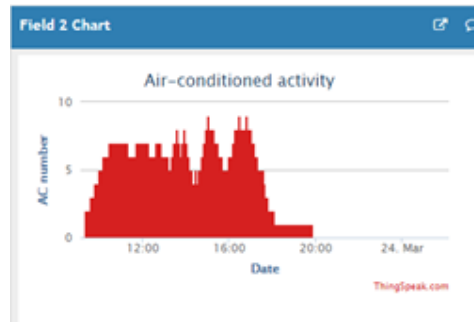

(f)

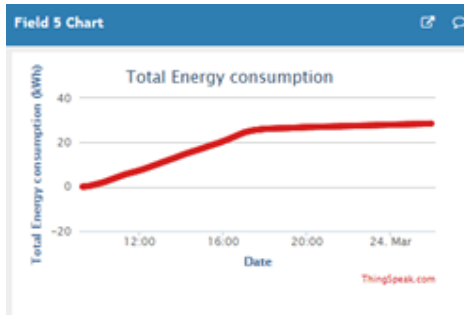

(g)

Figure 2.0: Real time monitoring of SH using Thingspeak IoT platform (a) Humidity (b) Temperature °C (c) air condition activities (d) operation of all the lightings (e) power consumption for lights, (f) power consumption for air condition, and (g) accumulated power consumption

The preliminary results in Figure 2, illustrates the monitoring activities and power usage. The results of the data analysis are not included in this paper due to limited space. From Figure 2 (c) and (d) shows that the number of lighting points and air-condition active after 19.00 hours reduces. This is because of less activities after 19.00 hours. This results to a corresponding decrease in energy consumption as shown in Figure 2 (e) and (f), respectively.

5 CONCLUSION

In this paper, a system for coordinating applications, saving, time, energy and money (CASTEM) in a smart home has been presented. It incorporates IoT and data analysis to enhance the living standard, reduce wastages, optimize energy consumption within a smart home. The system incorporates a gateway, IoT cloud and Wi-Fi communication technology. Future works intend to implement SH in wireless communication building using the narrow-band IoT (NB-IoT) communication technology, provide analyses and test the optimization techniques.

REFERENCES

- [1] Q. Ni, A. Belén, G. Hernando, I. Pau, and D. Cruz, "A Context-Aware System Infrastructure for Monitoring Activities of Daily Living in Smart Home," vol. 2016, 2016.
- [2] A. Bhati, M. Hansen, and C. M. Chan, "Energy conservation through smart homes in a smart city: A lesson for Singapore households," *Energy Policy*, vol. 104, pp. 230–239, 2017.
- [3] M. B. Rasheed *et al.*, "Energy optimization in smart homes using customer preference and dynamic pricing," *Energies*, vol. 9, no. 8, 2016.
- [4] D. Pal, S. Funilkul, N. Charoenkitkarn, and P. Kanthamanon, "Internet-of-Things and Smart Homes for Elderly Healthcare: An End User Perspective," *IEEE Access*, vol. 6, pp. 10483–10496, 2018.
- [5] A. C. Jose and R. Malekian, "Improving Smart Home Security: Integrating Logical Sensing into Smart Home," *IEEE Sens. J.*, vol. 17, no. 13, pp. 4269–

- 4286, 2017.
- [6] V. Yadav, S. Borate, S. Devar, R. Gaikwad, and A. B. Gavali, "A Review on Smart Home Automation using Virtue of IoT," vol. 2, no. 1, pp. 1–3, 2017.
- [7] B. Li *et al.*, "Acoustic modeling for Google home," in *Proceedings of the Annual Conference of the International Speech Communication Association, INTERSPEECH*, 2017, vol. 2017–August, pp. 399–403.
- [8] C. Chen, B. Das, and D. J. Cook, "A data mining framework for activity recognition in smart environments," *Proc. - 2010 6th Int. Conf. Intell. Environ. IE 2010*, 2010.

MANAGEMENT AND SOCIAL SCIENCE

Benefits of Electronic Commerce Technology Adoption among Small and Medium Sized Enterprises in Nigeria

Kabir Alhaji Abiso¹ and Musibau Akintunde Ajagbe^{2*}

¹Finance Department, Kala Balge Local Government Council, Maiduguri, Nigeria.

²Faculty of Management Sciences, Durban University of Technology, RSA

* ajagbetun@gmail.com

Abstract— Though, Nigeria has a very huge population and it's potentially a very lucrative market for electronic commerce (e-commerce) services. Notwithstanding the substantial number of the populace who has access to the internet, not many of the small and medium sized enterprises (SMEs) adopt e-commerce in conducting their day to day business operations. This study explored the benefits of e-commerce technology adoption among SMEs in Nigeria. A semi-structured interview guide was used to collect data from 25 SMEs owners in Maiduguri city, Nigeria. Recorded data were transcribed verbatim, coded and manually analysed through thematic and content analysis technique. The authors reported that the three categories of people who benefit from e-commerce adoption in Nigeria are the entrepreneurs himself, the customers and the organization. The findings are presented in the perspectives of the entrepreneurs as regards how business owners, customers and organizations benefit from e-commerce technology adoption in the day to day operations of small and medium sized enterprises. This study recommended that future authors could extend the data collection to customers in order to compare their perspectives to that provided by the entrepreneurs or business owners.

Keyword— Electronic Commerce, Small and Medium Sized Firms, Perceived Benefits, Technology Adoption, Nigeria.

1 INTRODUCTION

This article commenced with a background discussion concerning the research area. The background of the study consisted of a brief literature review of the concept of small and medium sized enterprises (SMEs), the concept of electronic commerce technology, and importance of e-commerce technology among SMEs. The next section presented the methodology for the study, the analysis of demographic profile, interview analysis and discussion, and conclusion of the study.

1. BACKGROUND OF THE STUDY

Small and medium sized enterprise (SME) is an economic coinage that has been defined in various forms and shapes. However, the quantitative perspective of SMEs has been based mainly on the turnover or assets and number of employees. Nonetheless, the qualitative opinion depend on how the firm is integrated (Hajiha et al., 2010; Hajli and Bugshan, 2012; Bilau et al., 2015a; Bilau et al., 2015b; Bilau et al., 2015c). Hence, empirical research has exposed some definitions including government agencies. The Small Business Administration in America cited in Saffu et al. (2012) based their definition on section 3 of the Small Business Act of 1953. The act defined an SME as one that is independently owned and operated and which is not dominant in its field of operation. Authors in United Kingdom took a more quantitative strategy, describing the concept as: having less than 50 personnels and is not a subsidiary of any other organization. In addition, few other authors described an SME as: one in which one or two persons are

required to make all of the critical decisions without the aid of internal specialists and with owners only having specific knowledge in one or two functional areas of management (Turban et al., 2010; Hajli and Bugshan, 2012). Not only do the definitions of SME vary, but there are wide ranging views on the characteristics of SMEs in various countries and contexts (Cragg et al., 2011; Ghobakhloo et al., 2011). Nonetheless, Ghobakhloo et al. (2011) concluded that SMEs are not 'small large businesses' but are a separate and distinct group of organizations compared to large businesses.

Agwu and Murray (2015) reported that SMEs today, represent about 90% of firms in the Nigerian industrial sector on numerical basis. Saffu et al. (2012) stressed that to remain competitive at the international arena, firms today must prepare themselves and their employees to function successfully in a knowledge-based economy (Ajagbe, 2014). However, information technology (IT) was suggested as an important instrument in meeting that challenge. Oluyinka et al. (2014) suggested that by accelerating their ability to master IT, SME owners will enable themselves and their employees to compete successfully in today's global knowledge economy.

Electronic commerce (EC) has been defined in several ways depending on the context and objective of the study. Jamali et al. (2015) perceived e-commerce in SMEs as the utilization of ICT and applications to support business activities. The authors elaborated the definition where they refer e-commerce as a set of technology that is utilized to support online business transactions between the organizations and their direct end customers and between the organizations and others within their business network(s). Turban et al. (2010) provided a more specific definition

where they stated that “e-commerce is the process of buying, selling, transferring, or exchanging products, services and/or information using computer networks mostly the Internet and Intranets.” Gomez (2012) argued that e-commerce is useful for SMEs because they play a vital role in shaping the future economy and even considered as the backbone of industrial development of any nation. The SME sector has a huge potential not only to promote domestic-led growth but also to strengthen the infrastructure in the country. Moreover, in this new competitive environment, SMEs need to adopt innovative and informed e-marketing strategies to remain distinct, profitable and succeed in domestic and international markets.

The realization of the importance of ICT adoption in SMEs has motivated many countries to spend more on ICT solutions and awareness programs in order to gain the promised benefits (Gomez, 2012; Abiso and Ajagbe, 2018). Researchers have discussed adoption of internet and e-business by SMEs in the developed countries (Solomon and Ajagbe, 2014). However, there are limited studies discussing ICT adoption in developing countries. Despite the importance of ICT and the emphasis laid by various governments to encourage its adoption, SMEs have been slow in taking it up for various reasons. One of the reasons may be the perceptions that the benefits of ICT implementation may not outweigh the cost. Dixon (2010) revealed that Malaysian SMEs were slow in the adoption of internet-based ICT due to their perceived lack of necessity for their businesses and also due to financial constraints. Gomez (2012) examined the relationships between use of ICT, the benefits a firm derives from membership in a rural business cluster and the success of rural companies.

Agwu and Murray (2015) stressed that a well articulated e-commerce within an organisation often facilitates growth and expansion. Awiagah et al. (2015) however stated that the application and use of e-commerce in developing countries can lead to substantial savings in communication costs, marketing, advertising, as well as production processes and the delivery of goods and services to various parts of the globe. MacGregor (2010) further stressed that the possibility of shopping online from anywhere is the most obvious and most commonly cited advantage of e-commerce, and was found to be the most important perceived consumer benefits of internet shopping. Saffu et al. (2012) in the submissions argued that since the boundaries of e-commerce are not defined by geographical or national borders, consumers will benefit from a wide selection of vendors and products, including a wider availability of hard-to-find products. Thus, the objective of this research is to explore the perceived benefits of adoption of e-commerce technology among small and medium sized enterprises in Nigeria. Hence, the main research question of this study is: how beneficial is the adoption of e-commerce technology among small and medium sized enterprises in Nigeria?

3 METHODOLOGY

The qualitative research paradigm was chosen for this study because a review of the literature indicated a need for a better understanding of the experience of owners of

SMEs in Nigeria who have used e-commerce technology in their day to day business operations (Ajagbe, 2014; Ajagbe, et al., 2015; Abiso, 2017). This study employs purposeful sampling and the case study as a reporting mechanism. The researchers used the organisational unit of analysis to measure the selected sample population for the study. The triangulation technique was used by collecting data with the use of multiple approaches. This study followed an inductive qualitative approach, and consisted of an average of 67 minutes interviews with about 25 participants from selected SMEs in Maiduguri city, Nigeria which have high rates of internet penetration. The respondents are SMEs owners who have adopted electronic commerce technology in their business operations.

Initial data was coded to indicate the concept or dimension it represents, and the researcher linked concepts together into a theory, or explanation of the phenomenon studied. Tesch (1990) posited that analyzing qualitative data requires understanding how to make sense of text and images so that you can form answers to your research questions. Creswell (2007) opined that qualitative research is an interpretative research, in which you make a personal assessment as to a description that fits the situation or themes that capture the major categories of information. The interpretation that you make of a transcript, for example, differs from that someone else makes. This does not mean that your interpretation is better or more accurate; it simply means that you bring your own perspective to your interpretation (Taylor et al., 2006). For the purpose of this analysis, the researcher used both “in vivo codes and lean codes” because it was sometimes discovered to be necessary to use the codes exactly the same way the participants mentioned during the interview, while other situations warrants the researcher to rephrase the words in his own words. Table 1 showed the result of the coding process.

Table 1: Result of the coding process

Major Emerging Code	Sub-Codes	Coding Categories
Benefits of E-Commerce	2 Sub-Codes	112 Codes
Main Code	2 Sub-Codes	112 Codes

4 ANALYSIS OF DEMOGRAPHIC PROFILE

Analysis of the gender profile revealed that 06(24%) among 25 respondents are females while 19(76%) among 25 respondents are males. This is an indication that majority of the respondents interviewed are males. It could also mean that more males are involved in trading activities in northern part of Nigeria.

Analysis of the educational profile revealed that 01(4%) among 25 respondents are master degree graduate, 09(36%) among 25 respondents have bachelor degree, 08(32%) among 25 respondents have OND/NCE and 07(28%) among 25 respondents have SSCE/PSLC. This indicates that majority of the respondents have requisite level of education to participate in the interview.

Analysis of the SMEs surveyed revealed that supermarkets

consisting of 9 participants and represents 36% of the participants of the study, restaurants consisting of 10 participants represents 40% of the participants of the study, boutique consisting of 4 participants represents 16% of the participants of the study and furniture consisting of 2 participants represents 8% of the total participants interviewed for the study.

5 INTERVIEW ANALYSIS AND DISCUSSION

5.1 Emerging Themes from the Study

5.1.1 Benefits of Adoption of E-Commerce as an Entrepreneur

Saffu et al. (2012) argued that SMEs have actively searched for methods that are suitable to adopt and integrate e-commerce into their business processes. The authors suggested the benefits of e-commerce implementation are; increased sales, improved profitability, increased productivity, reduced costs associated with inventory, procurement and distribution, improving the quality of service, and guarantee competitive position. This statement compliments the result of this study about the need to understand the benefits of adopting e-commerce technology by SME owners. Analysis of interview transcript revealed that they benefits of adopting e-commerce technology by SMEs include; reduction of stress, less time consuming, it help in reducing the movement of money from one location to another, makes business transaction less cumbersome for the participants. This enhances customers' satisfaction as business funds are secured and proper accountability is encouraged. Respondent 12 who is an SME owner mentioned that:

"I am glad that we invested in E-Commerce because it makes it easy for me to oversee my business from afar and monitor other branches without been physically present. It makes work easy for our employees and also helps in smooth running of our business activities"

In addition, Ghobakhloo et al. (2011) examined the adoption of e-commerce by SMEs and found that SMEs could gain competitive advantage through adopting e-commerce as it could improve their market performance by having better access to the market. Oluyinka et al. (2014) found among other issues that SMEs markets needed a high degree of human interaction.

5.1.2 Benefits of Adoption of E-Commerce as a Customer

Thus, interview analysis indicated that they benefits of adopting e-commerce technology by customers of small and medium sized enterprises include; It makes their transaction or buying easy, It reduces stress of going to bank, It makes the business customer friendly, they enjoy cashless system of payment, customers feel comfortable with service and product delivery. However, in line with the current findings, MacGregor (2010) stressed that the possibility of shopping online from anywhere is the most obvious and most commonly cited advantage of e-commerce, and was found to be the most important perceived consumer benefits of internet shopping. Saffu et al. (2012) in their submissions argued that since the boundaries of e-commerce are not defined by geographical or national borders, consumers will benefit from a wide selec-

tion of vendors and products, including a wider availability of hard-to-find products. According to respondent 15 who is an owner of a supermarket stressed that:

"electronic commerce makes it less stressful and less cumbersome for his customers to shop for goods and services because they can make payment at the comfort of their home and receive goods within a short period of time".

5.1.3 Benefits of Adoption of Electronic Commerce as an Organization

In this study, findings from analysed interview transcript revealed that to a great extent introduction of e-commerce enhances positive business operations. It increases the rate of customer participation, provides suitable environment for competition, increase in income and enhances ease of work. In addition, electronic commerce increases the rate of customer patronage, it improves efficiency of doing business and enhances ease of work processes on the side of the employees. Thus, one of the respondents who is an owner of a furniture outlet stressed that;

"adoption of e-commerce technology bring the following benefits to the firm; enhances production and product delivery, internationalisation, increase in income and ease of work, increases the number of customers to the firm, reduces the movement of cash both from customer and organization (RES 4)".

The findings from this research is consistent with previous findings from Agwu and Murray (2015), who stressed that a well articulated e-commerce within an organization often facilitates growth and expansion. Awiagah et al. (2015) however stated that the application and use of e-commerce in developing countries can lead to substantial savings in communication costs, marketing, advertising, as well as production processes and the delivery of goods and services to various parts of the globe.

Category of Responses	No of Responses	%age of Responses
Yes, Beneficial	22	88
No, don't think so	03	12
	25	100

Table 2: Benefits of Adoption of E-Commerce

However, from table 2 above, analysis of interview transcript indicated that 22(88%) among 25 respondents mentioned that they use of e-commerce is beneficial to their organizations, whereas 03(12%) among 25 respondents do not think that adopting internet technology is beneficial to their business operation. Table 2 showed responses from participants who believed that adoption of e-commerce is beneficial to SMEs as it emerged from the coded interview transcript.

6 CONCLUSION

The aim of this study was to find out the benefits of e-commerce adoption among SMEs in Nigeria. This study reported that the three categories of people who benefit from e-commerce adoption in Nigeria are the entrepre-

neurs himself, the customers and the organization. In this, study the entrepreneurs revealed that they have benefited; through increased sales, improved profitability, increased productivity, reduced costs associated with inventory, procurement and distribution, improving the quality of service, product and service awareness, and guarantee competitive position. However, from the perspective of the business owners, their customers have also benefited from e-commerce technology adoption because: it makes transaction or buying easy, reduces the stress of going to bank, enjoy cashless system of buying, customers can make their choice online, comfortability with product delivery. From the perspective of the business owners, their organization has benefitted from adopting e-commerce technology in areas of: increased business expansion, enhanced profitability, internationalization of business operations, strong competitive advantage, improved organization image and integrity. This study recommended that future authors could extend the data collection to customers and SME managers in order to compare their perspectives to that provided by the entrepreneurs or business owners. Also themes that have emerged from this study could be quantitatively tested to determine the generalizability of findings from this study.

7 REFERENCES

- [1] Ajagbe, A. M. (2014). Funding Criteria in Technology Based Firms. An Unpublished Thesis submitted to Universiti Teknologi Malaysia in partial Fulfilment of award of Doctoral Degree in Management.
- [2] Abiso, A. K. (2017). Electronic Commerce Technology Adoption among Small and Medium Sized Firms in Nigeria. PhD Thesis submitted to Graduate School, Oxford University, Namibia.
- [3] Ajagbe, A. M., Isiafwe, T. D., Sholanke, B. A. and Oke, A. O. (2015). Qualitative Inquiry for Social Sciences. In the Proceedings of the Covenant University International Conference on African Development Issues (CU-ICADI 2015) held on 11-13th May, pp. 319-325.
- [4] Agwu, M. E. and Murray, J. P. (2015). Empirical Study of Barriers to Electronic Commerce Adoption by Small and Medium Scale Businesses in Nigeria. *International Journal of Innovation in the Digital Economy*, 6(2): 1-19.
- [5] Awiafah, R., Kang, J. and Lim, I. J. (2015). Factors affecting e-commerce adoption among SMFs in Ghana. *Information Development*, 1-22.
- [6] Abiso, K. A. and Ajagbe, A. M. (2018). Adoption of Electronic Commerce Technology in Emerging Nations: A Conceptual Review of the Literature. *International Journal of Economics, Commerce and Management*, UK. Vol. VI, Issue 2, Pp. 455-472.
- [7] Bilau, A. A., Ajagbe, A. M., Bustani, A. S. and Sholanke, A. B. (2015). Review of Absorptive Capacity in Small and Medium Sized Construction Firms in Nigeria. *Journal of Developing Country Study*, 5(16): 52-61.
- [8] Bilau, A. A., Ajagbe, A. M., Kigbu, H. H. and Sholanke, A. B. (2015). Review of Shortage of Skilled Craftsmen in Small and Medium Construction Firms in Nigeria. *Journal of Environment and Earth Science*, 5(15): 98-110.
- [9] Bilau, A. A., Ajagbe, A. M., Bustani, A. S. and Sani, T. A. (2015). Absorptive Capacity for Firms Development: Impending Factors for Small and Medium Sized Construction Firms. *Journal of Civil and Environmental Research*, 7(8): 12-25.
- [10] Cragg, P., Calderia, M. and Ward, J. (2011). Organisational Information Systems Competencies in Small and Medium-Size Enterprises. *Information & Management*, 48(8): 353-363.
- [11] Creswell, J. W. (2007). "Qualitative inquiry and research design: Choosing among five approaches" 2nd ed. Thousand Oaks: Sage Publications, 127-147.
- [12] Dixon, B. E. (2010). Towards E-Government 2.0: An Assessment of Where E-Government 2.0 Is and Where It Is Headed," *Public Administration & Management*, 15, 418-454.
- [13] Ghobakhloo, M., Arias-Aranda, D. and Benitez-Amado, J. (2011). Adoption of e-commerce applications in SMFs. *Industrial Management & Data Systems*, 111(8): 1238-1269.
- [14] Gomez, L. S. (2012). Innovation Adoption in Family Businesses from Developing Countries: The Case of Colombia. Paper presented at the annual meeting of the SASE Annual Conference 2012, M.I.T., Cambridge, MA.
- [15] Hajiha, A., Ghaffari, F. and Hajihashemi, L. (2010). The Survey of Effective Behavioral Factors on Decision Making of Acceptance the Electronic Commerce, by Managers of SMFs in Tehran. *Journal of Management Research*, 20(83): 17-31.
- [16] Hajli, M. and Bugshan, H. (2012). E-Commerce Pre-Adoption Model for SMFs in Developing Countries. Proceedings of the 2012 International Conference on e-Learning, e-Business, Enterprise Information Systems, and e-Government, Las Vegas, United States.
- [17] Jamali, S. K., Samadi, B. and Gharleghi, B. (2015). Factors Influencing Electronic Commerce Adoption: A Case Study of Iranian Family SMFs. *International Journal of Business and Social Science*, 6(2): 178-199.
- [18] MacGregor, R. and Kartiwi, M. (2010). Perception of Barriers to e-Commerce adoption in SMFs in a Developed and Developing Country: A Comparison between Australia and Indonesia. *Journal of Electronic Commerce in Organizations*, 8(1): 61-82.
- [19] Oluyinka, S., Shamsuddin, A., Wahab, E., Ajagbe, A. M. and Imoudu, W. (2014). A study of electronic commerce adoption factors in Nigeria. *International Journal of Information Systems and Change Management*, 6(14): 293-314.
- [20] Solomon, O. and Ajagbe, A. M. (2014). Internet Banking Adoption in Nigeria: A Literature Review. 2014 International Conference on Computer, Intelligent Computing and Education Technology,

March 28th, Hong Kong.

- [21] Saffu, K., Walker, J. H. and Mazurek, M. (2012). Perceived Strategic Value and e-Commerce Adoption among SMFs in Slovakia. *Journal of Internet Commerce*, 11(1): 1-23.
- [22] Turban, E., King, D., Lee, J., Liang, T. P. and Turban, D. (2010). *Electronic commerce: A managerial perspective 2010*. Upper Saddle River, NJ: Pearson Prentice Hall.
- [23] Tesch, R. (1990). "Qualitative Research: Analysis Types and Software Tools" Bristol, PA: Falmer Press.
- [24] Taylor, B., Sinha, G. and Ghoshal, T. (2006). "Research Methodology: A Guide for Researchers in Management and Social Sciences." (Eastern Economy Ed), New Delhi: Prentice-Hall.

Impact of Liquidity Management on Profitability in Nigeria's Banking Sector

Oluwatobi Fagboyo*, Abayomi Adedeji, Anjola Adeniran

Department of Banking and Finance, Covenant University, Ota, Ogun State.

*tobifagboyo@gmail.com

Abstract— This paper seeks to analyse the impact of liquidity management on profitability within the Nigerian deposit money banks. This will cover the period of ten years (2007-2016). Five banks have been chosen to represent the population of the twenty-four deposit money banks in Nigeria. The liquidity indicators square measure quick ratio, cash ratio, current ratio and liquidity coverage ratio, whereas return on equity (ROE) and return on assets (ROA) were proxies for profitability. Regression analysis was used to test the hypothesis. The findings indicate that liquidity management considerably impact on the performance of deposit money banks. The empirical results additionally shows that a rise within the quick ratio of accessible funds results in a rise within the profitability, whereas a rise within the cash ratio and the liquidity coverage ratio results in decrease within the profitability of the deposit cash banks in Nigeria. Recommendation therefore is that for economic, effective, efficient management of liquidity, the banks ought to adopt a general framework for liquidity management, additionally competent personnel's ought to be used to enable them get optimum result for profitability.

Keywords: liquidity; profitability; return on asset; return on equity

1 INTRODUCTION

Generally, the maintenance of adequate liquidity level plays a really vital role within the effective operations of all organisations all over the globe; liquidity management could be a notion that's obtaining serious attention above all thanks to the present financial situations and the state of the global economy, (IBE 2013). Some of the outstanding corporate goals embody the necessity to maximise profit, sustain a high level of liquidity so as to ensure safety, reach the best level of owner's internet value as well as the attainment of alternative company objectives. The importance of liquidity management as it affects the company gain in today's business can't be over stressed. Liquidity plays a serious role within the effective functioning of a business organisation. Therefore, a firm ought to make sure that it doesn't suffer from lack of or excess liquidity to fulfil its short compulsions.

The Basel committee, in response to the worldwide monetary crisis of 2007 – 2010, has projected a replacement set of liquidity needs to enhance its revised framework of capital needs (Calomiris et al 2012). As a results of the significant reliance of banks on financial organisation loaning throughout the crisis, policy manufacturers clearly would love to scale back the dependence of deposit cash banks on the investor of expedient, and therefore encourage banks to limit or self-insure (through money asset holdings) a number of their liquidity risk. In every system, there are major elements that are vital for the survival of the system; this is also applicable to the financial system. The financial institution have contributed vastly to the growth of the entire financial system, as they provide an efficient institutional method through which resources can be mobilized

and directed from less productive uses to more productive uses.

Deposit money banks have become a very necessary establishment within the financial system as it helps in facilitating the movement (of financial/ monetary/economic) assets that are less desirable to the more desirable public who requires the financial assets. An adequate financial intermediation needs the attention and focus of the bank management to the profitability and liquidity, which are the two conflicting objectives of the deposit money banks. These objectives are parallel in the sense that an attempt for a bank to attain higher profitability can bit by bit destroy its liquidity and solvency position and contrariwise (Eljelly 2004).

Practically, profitability and liquidity is an effective indicator of the company wealth and performance of not solely deposit money bank but to all or any profit orienting venture. These performance indicators are vital to the shareholders and depositors who are major publics of a bank, because the shareholders expect the bank to extend loaning so as to grant them maximum return in money invested with whereas the investor expect the bank to keep abundant idle cash in order to fulfil their demand. With the conflict arising between profitability and liquidity, shareholders and depositors interest, there is a need for reconciliation and harmonization through effective and efficient liquidity management to ensure the survival and growth of deposit money banks.

Deposit money banks that aim to survive must be aware of the challenges of its liquidity and profitability as both factors can affect a bank's growth and sustainability. Therefore, the main purpose of this study is to examine the

relationship between liquidity and profitability on deposit money banks in Nigeria.

From the roles of the financial institution, the deposit money banks make use of idle funds borrowed from the lenders (those who deposit their money into the bank) by investing such funds in other classes of financial assets investment for profit purposes. However, they can be faced with problems, since these deposits which have been invested by the banks for profit maximization can be demanded for at any time by the owners. When the bank is not able to meet their financial obligations, the public begins to lose confidence and these will cause lot of competition to the financial sector. With the increasing level of competition in the banking industry (currently twenty-four deposit money banks in Nigeria), every deposit money bank would strive to operate on profit and at the same time meet the financial demand of its depositors by maintaining adequate liquidity. The question then becomes; what is the best optimum solution to maintain proper profitability and liquidity in the banking sector? Where is the breakeven point between the two objectives? These questions have become a problem in the financial world as large number of banks are basically concern with profit maximization and tend to neglect the importance of liquidity management and these can lead to technical and legal financial condition.

For the fact that the deposit money banks operate on liquidity and profitability motives in the mind to satisfy their major publics, the shareholders and depositors, the stakeholders in all, the need arise for them to bring into agreement these two motives. With this the deposit money bank need effective and efficient liquidity management approaches and principles that will help them realize these motives. The result gotten form this study will reveal the level of attachment of the deposit money banks to the monetary policies (liquidity ratios) established by the government and these will help the government to set appropriate liquidity ratio's and cash ratio's that will not be harmful to the operation and survival of the deposit money banks.

The outline of the paper are as follows: Section one is the introduction, section two reviews related literature, section three is the research methodology and section four is the summary, conclusion and recommendations of the paper.

1.1 Research Question

The study seeks to answer the question below:

- Is there any significant relationship between liquidity and profitability on deposit money banks in Nigeria?

2 LITERATURE REVIEW

This chapter presents the literature review and it is

subdivided into different sections namely: conceptual framework (this review different authors' definitions related to the studies); theoretical review (this review the theories related to work); and the empirical review (this section review other past literature as well to the relation to the work.

2.1 Conceptual Framework

Liquidity is the rapidity and ease at which assets and be turned into cash without loss of interest and capital to meet financial obligations. Examples include: cash reserves, government debts securities etc. Liquidity is an important factor in order to meet everyday withdrawal demands at all times (Francis 2016). Banks should have sufficient number of profitable assets in order to pay dividends to their shareholders and still be able to transfer to reserve. Samiksha (2013) noted that it is important in order to meet everyday withdrawal demands at all times. Therefore for any bank to survive successfully and subsequently maintain the public trust and confidence in banking operations, it has to adopt liquidity management measures that shall put in place an adequate liquidity so that the various demands of customers shall always be met. If a bank refuses to maintain adequate liquid assets in their banking management, it stands the risk of endangering its existence by losing its various customers and public confidence in its operations. Profitability is the basic objective of any business and that is why shareholders always ask for returns on their investments. The opportunity cost of remaining liquid is returns foregone by not investing in assets with higher rate of return.

The conflict between the need for banks to remain liquid and the need to pursue profitability work in different directions to resolve this conflict, the bank management should be able to satisfy the demands of the opposing group which are shareholders whom are concerned with profitability and depositors whom are concerned with liquidity.

2.1 Theoretical Literature

There are several theories that have been put forward which seek to provide insight into the underlying relationship between liquidity and profitability of deposit money banks. Some of which includes:

- **Deposit money Loan Theory**

This theory maintains that a deposit money bank's liquidity would be assured as long as assets were held in short term loans that would be liquidated in the normal course of business. Banks are expected to finance the movement of goods through the successive stages of production to consumption or what would be called today as inventory or working capital loans.

- **The Shift Ability Theory**

The shift ability theory is based on the proposition

that the assets the banks hold are either to be sold to other lenders or investors or shifted to central bank which stands ready to purchase assets offered for sale.

- **The Anticipated Income theory**

This theory holds that liquidity can be ensured if scheduled loan payments are made on future income of the borrower. This theory relates loan repayment to income than rely on collateral. This theory also holds that a banks liability can be influenced by the maturity pattern of loans and investment portfolios.

- **The Liability Management Theory**

The liability management theory holds that banks can meet their liquidity requirement by bidding in the market for additional funds to meet loan demand and deposit withdrawal.

2.2 Empirical Literature

Andrew and Osuji (2013) analysed the efficiency of liquidity management and banking performance in Nigeria using a survey design. The findings showed that there is a significant relationship between efficient liquidity management and banking performance.

Francis, Frank and Raymond (2013) examined liquidity management and the performance of banks in Nigeria within the period 2000-2010. It studied the relationship between the variables of bank performance and those of liquidity management using bank deposit, cash reserve requirement, bank investment, and cash ratio as indicators. The sources of data were mainly collected from CBN’s statistical bulletin. The data sourced were analyzed using simple percentages and simple regression model. However, findings from the study indicated that a strong relationship exists between bank deposit and bank reserve requirement, and bank investment and cash ratio. The study recommended that banks should not focus purely on deposits but rather other measures be adopted to reduce illiquidity in this sector.

Godwin Bassey (2015) investigated the liquidity-profitability trade off of deposit money banks in Nigeria by carrying out a study on fifteen deposit money banks in Nigeria and covered a panel data of 2010 to 2012. The study adopted the Ordinary Least Squares (OLS) method of analysis to analyse the data. The outcomes gotten from this study discovered that there may be a statistically relationship between financial institution liquidity measures-current ratio, liquid ratio, cash ratio, loans to deposit ratio, loans to asset ratio- and return on equity.

Uremadu (2012) examined the effect of capital structure and liquidity on the profitability of selected Nigerian banks within the period 1980-2006. The method of analysis adopted was the descriptive statistics and regressive distributed lag (ARDL) model. The results showed there is a positive and significant relationship between cash reserve

ratio, liquidity ratio, corporate income tax and banks’ profitability

3 RESEARCH METHODOLOGY

Research is conducted on five deposit money banks in Nigeria which include UBA, ACCESS, ZENITH, ECO and FIRST Bank. The reason for this study is to decide the impact of liquidity administration on productivity in deposit money bank performance. Data is taken from financial annual reports of banks for the period of 10 years 2007-2016. It is Descriptive in nature and makes use of quantitative analysis. Our main focus is Profitability and Liquidity.

Profitability: There are various methods used for measuring profitability of an organisation. For the purpose of this study, the profitability of these banks will be determined using the return on asset and return on equity (ROA and ROE)

Liquidity: The liquidity will be calculated using Quick ratio, capital ratio, net credit facilities to total assets and liquid assets ratio

Population: It covers the 24 deposit money banks in Nigeria

Sample size: For the purpose of this study, the sample size is the five selected banks; UBA, ACCESS, ZENITH, ECO and FIRST Bank.

Data Analysis: To understand approximately the connection between dependent proxies of profitability and independent proxies of liquidity variables of banks, a pooled analysis will be used. This will help us find the correlation and regression between profitability (dependent variable) and liquidity (independent variable).

$$ROA_{it} = \beta_0 + \beta_1 QR_{it} + \beta_2 CR_{it} + \beta_3 LCR_{it} + \epsilon_{it} \dots\dots\dots 1$$

$$ROE_{it} = \beta_0 + \beta_1 QR_{it} + \beta_2 CR_{it} + \beta_3 LCR_{it} + \epsilon_{it} \dots\dots\dots 2$$

4 RESULTS

Table 1 shows the mean, standard deviation, count, minimum and maximum qualities of data.

TABLE 1: Descriptive Statistics

	N	Minimum	Maximum	Mean	Std. Deviation
ROA	50	.009	.250	.06116	.076999
ROE	50	.060	1.290	.16812	.165386
QR	50	.130	1.500	1.25620	.194158
CR	50	.220	.660	.49620	.086753
LCR	50	.390	1.050	.57330	.222028
Valid N	50				

TABLE 2: Correlation

Correlation	ROA	ROE	QR	CR	LCR
ROA	1	-.021	.073	-.312*	-.358*
ROE	-.021	1	.178	-.083	-.280*
QR	.073	.178	1	-.099	-.187
CR	.312*	-.083	-.099	1	.308*
LCR	-.358*	-.280*	-.187	.308*	1

Correlation¹ is significant at the 0.05 level (2-tailed)

a. Dependent Variable: ROA

Table 3: Model Summary

Model	R	R Square	Adjusted R Square	Std. Error of the Estimate
1	.416 ^a	.173	.119	.072255

b. Predictors: (Constant), LCR, QR, CR

The R square from the table is at 17.3%. This shows the level of dependence on the independent variable. The dependent variables have a strong relationship with the independent variables. The dispersion of data is at 11.9%.

The Analysis of Variance (ANOVA as shown in Table 4 shows significant level of 0.031; hence, we accept H1 and reject H0. There is a significant level of relationship between Return on asset and liquidity.

Table 4: ANOVA

Model	Sum of Squares	df	Mean Square	F	Sig.
Regression	.050	3	.017	3.215	.031 ^b
Residual	.240	46	.005		
Total	.291	49			

Table 5: Model

Model	Unstandardized Coefficients		Standardized Coefficients	t	Sig.
	B	Std. Error	Beta		
(Constant)	.219	.097		2.259	.029
QR	-.001	.054	-.003	-.022	.983
CR	-.198	.125	-.223	-1.584	.120
LCR	-.101	.050	-.290	-2.029	.048

Likewise the ROE,

Table 6: Model Summary

Model	R	R Square	Adjusted R Square	Std. Error of the Estimate
1	.308 ^a	.095	.036	.162388

a. Dependent Variable: ROE

b. Predictors: (Constant), LCR, QR, CR

Table 7: ANOVA

Model	Sum of Squares	df	Mean Square	F	Sig.
Regression	.127	3	.042	1.609	.200 ^b
Residual	1.213	46	.026		
Total	1.340	49			

Table 8

Model	Unstandardized Coefficients		Standardized Coefficients	t	Sig.
	B	Std. Error	Beta		
(Constant)	.130	.218		.595	.554
QR	.111	.122	.131	.914	.366
CR	.019	.281	.010	.067	.947
LCR	-.193	.111	-.259	-1.731	.090

4. ANALYSIS AND DISCUSSION OF RESULTS

From the table, the relationship between the variables are been shown, the cash ratio has a negative relationship with the ROE and quick ratio but has a positive relationship with ROA, cash ratio and the liquidity coverage ratio.

Also the Return on asset has a positive relationship with ROA and quick ratio but has a negative relationship with ROE, cash ratio and LCR. The R square also shows a high level of dependence on the independent variable. Based on the research findings, it can be concluded that there is an effect of the liquidity management on profitability as measured by return on asset or equity (ROE or ROA), where the effect of the quick ratios on the profitability is positive when measured by ROA and ROE, and the effect of cash ratio on profitability is positive as measured by ROA.

5. CONCLUSION AND RECOMMENDATION

This research aims at investigating empirically the impact of liquidity management on profitability of Nigerian deposit money banks, and how these banks can keep balance between liquidity and profitability. It is recommended that there is a need to invest the excess of liquidity available at the banks, in various aspects of investments in order to increase the banks' profitability and to get benefits from the time value of the available money, also the banks should adopt a general framework for liquidity management to assure a sufficient liquidity for executing their works efficiently.

6. REFERENCES

- [1] Abdullah, M. N. (2014). The impact of liquidity on profitability in banking sector of Bangladesh. *Economic and business review*, 2(10). Retrieved April 2, 2016, from www.epratrust.com
- [2] Ahmad, B. R. (2016). A Study of Relationship between Liquidity and Profitability of Standard Chartered Bank Pakistan: Analysis of Financial Statement Approach. *Double Blind Peer Reviewed International Research Journal*, 16(1). Retrieved March 26, 2016
- [3] Ali SuliemanAlshatti, A. A. (2014). The Effect of the Liquidity Management on Profitability in the Jordanian Deposit money Banks. *International Journal of Business and Management*, 10. doi:10.5539/ijbm.v10n1p62
- [4] Asian Umobong, F. (2015). Assessing the impact of liquidity and profitability ratios on growth of profits in pharmaceutical firms in Nigeria. *European Journal of Accounting, Auditing and Finance Research*, 3, 97-114. Retrieved March 2016, from <http://www.eajournals.org>
- [5] Eljelly M.A, (2004) Liquidity - profitability tradeoff: An empirical investigation in an emerging market, *International Journal of Commerce and Management*, Vol. 14 Issue: 2, pp.48-61, <https://doi.org/10.1108/10569210480000179>
- [6] Francis, A. (2016). Liquidity Management and the Performance of Banks in Nigeria. *International Journal of Academic Research in Accounting, Finance and Management Sciences*, 41-48.
- [7] Godwin, E. B. (2015). Bank Profitability and Liquidity Management . *International Journal of Economics, Commerce and Management*, 2-24.
- [8] Idowu, A., & Adegboyega, R. (2017). Liquidity management and banks performance in Nigeria. *Issues in Business Management and Economics*, 88-98.
- [9] Olagunju, A., & Adeyanju, O. (2011). Liquidity Management and Deposit money Banks. *Research Journal of Finance and Accounting*, 24-38.
- [10] Sanishka, C. (2013). Liquidity Concepts, Instruments and Procedure. *Economy and Finance.*, 316-314.
- [11] Sunny, O. I. (2013). The Impact of Liquidity Management on the Profitability of Banks in Nigeria. *Journal of Finance and Bank Management*, 37-48.
- [12] Uremadu, S. (2012). Bank Capital Structure, Liquidity and Profitability Evidence from the Nigerian Banking System. *International Journal of Academic Research in Accounting, Finance and Management Sciences*, 20-30.

Awareness and Readiness to Adopt Electronic Commerce by Small and Medium Firms in Borno State

Alhaji Kabir Abiso¹ and Musibau Akintunde Ajagbe^{2*}

¹Finance Department, Kala Balge Local Government Council, Maiduguri, Nigeria.

²Faculty of Management Sciences, Durban University of Technology, RSA

* ajagbetun@gmail.com

Abstract— This study explored the awareness and readiness to adopt e-commerce by small and medium firms (SMFs) in Borno State, Nigeria. A semi-structured interview guide was used to collect data from 25 SMF owners in Maiduguri city. Recorded data were transcribed verbatim, coded and manually analysed through thematic and content analysis technique. This study reported that SMFs in Nigeria fully understand the concept of e-commerce as described by various respondents. Also, this study found that adoption of e-commerce technology by SMFs depends on managements' decision and readiness. In addition, some SMFs are already adopting and some are ready to adopt e-commerce in the day to day transactions of their businesses provided appropriate infrastructure and encouragement are made available by government.

Keyword— Small and Medium Firms, E-Commerce Readiness, E-Commerce Awareness, Technology Adoption, Nigeria.

1 INTRODUCTION

The background of this research contain a short review of archival studies relating to the concept of small and medium firms (SMFs), the electronic commerce (e-commerce) technology concept, level of awareness and readiness to adopt electronic commerce, and importance of e-commerce technology among SMFs. In the following section, the researchers presented the methodology, the analysis of demographic profile, interview analysis and discussion, and conclusion of the research.

2 BACKGROUND OF THE STUDY

In the developed countries of Western Europe, North America and the newly industrializing countries of Asia, research has shown that a consensus exist among SMF owners that implementation of e-commerce technology will transform business activities (Oluyinka et al., 2014; Abiso and Ajagbe, 2018). However, in Nigeria, there is a copycat approach in adopting e-commerce technology (Usoro, 2010). However, for Jamali et al. (2015), family SMFs beign the majority of businesses and are the most spread businesses across the world, play a dominant role in the global economy. This is done by creating a safe and transparent investment environment and overcoming the milieu of economic crisis. Ukoha et al. (2011) stressed that family SMFs are the crucial sector, not merely based on their critical involvement in economy, but that they present long-term steadiness and responsibility. They represent 70-90% of the global gross domestic product (GDP), 50% of the GDP and employment in US (Oluyinka et al., 2014; Olatokun and Kebonye, 2010). In Europe, over 60% of the business organizations in most of the industries are SMFs (OECD 2009). In Australia, two-thirds of SMFs are dominant form of business (Voges and Pulakanam, 2011).

Whereas in Japan, over 90% of local ventures are SMFs, 95% of the private firms in the Middle East are dominated by small and medium firms sector. This comprise of about 98% of businesses in Iran (Usoro, 2010; Ukoha et al., 2011; Jamali et al., 2015b). Hence, national economic growth in many societies are highly dependent on contribution from family SMFs. Thus, such group of firms has direct impact on poverty reduction and employment.

Eventhough, as argued by Ukoha et al. (2011) that the adoption of e-commerce by SMFs in Nigeria is a new development, the internet services have widely been accepted among large and some medium sized firms. Thus, most SMFs are still lagging behind in the adoption of e-trading. Nonetheless, the inability of this category of firms to take advantage of this innovative technology forms the crux of this research. Previous studies have shown that the adoption of information technology (IT) by SMFs is still lower than expected in Nigeria and many other developing countries (Usoro, 2010; Oluyinka et al., 2014). Several barriers to IT adoption have been identified, including: lack of knowledge about the potential of IT, a shortage of resources such as financial and expertise, and lack of skills. Many studies have also focused on identifying the determinants that influence IT adoption (Sharma et al., 2013; Abiso, 2017; Abiso and Ajagbe, 2018). Some studies looked into a broader perspective of Internet adoption and found that environmental factors such as government intervention, public administration, and external pressure from competitors, suppliers, and buyers play the key role in the adoption and implementation of information technology, especially in e-commerce (Sharma et al., 2013). Other studies focused instead on the organizational factors, such as organization support and management support; however, few studies focused on skills and use among the owners (Jamali et al., 2015; Usoro, 2010). Hence, this study focussed on the awareness and

readiness of adoption of e-commerce technology among small and medium firms in Nigeria.

Agwu and Murray (2015) argued that the adoption of e-commerce is depends specifically, on cultural, social, legal, economic, political context and physical infrastructures which could vary significantly among countries. However, research on information communication technology (ICT) related areas and essentially e-commerce has emphasized on developed countries (Jamali et al., 2015; Dahnil et al., 2014). Thus, in emerging nations, e-commerce presently occupy a substantial portion of small firms activities and it is believed that it will grow continuously over time. Hence, the growth of e-commerce has resulted in notable impact on the overall economy through its impact on productivity and inflation (Abiso and Ajagbe, 2018). Nevertheless, Abiso (2017) concluded that consumers have the option to enjoy the benefit of reduction in costs in terms of the time and effort needed to initiate and conclude business dealings.

There is insufficient research in the domain of e-commerce in developing nations with particular emphasis on Nigeria. Though, the few available studies in this area have laid more emphasis on South Africa (Ayo et al., 2011; Abiso, 2017). However, considering the insufficient study in e-commerce activity in developing nations, there might be need to think that outcomes from research carried out in developed countries may not be applicable to developing countries. Thus, one might argue that findings from developed countries are not directly transferable to developing countries and that differences in country-contexts can lead to varying adoption and impact patterns of ICT (Agwu and Murray, 2015; Ukoha et al., 2011).

Dahnil et al. (2014) posited that online trading has exposed new set of social and ethical concerns as writers with opposing views are concerned about online privacy. However, highlighting these concerns will therefore not be out of place as it will help to deepen our understanding as well as give assurance that will remove doubts in the adoption of e-commerce (Agwu and Murray, 2015; Jamali et al., 2015). In view of this, the e-commerce adoption literature has implied that in order to successfully implement e-commerce in developing countries, SMFs are required to be both internally and externally ready. Alatawi et al. (2013) defined this readiness in-term of electronic readiness of an SMF as the ability of a firm to successfully adopt, use, and benefit from e-commerce. Ahn and Matsui (2011) demonstrated that in initial adoption of e-commerce in developing countries, internal (organisational) readiness is essentially important. Saffu et al. (2008) defined internal e-commerce readiness as the availability of financial and technological capabilities, the interest of entrepreneurs and or senior managers to adopt e-commerce, e-commerce technology infrastructure, firm's compatibility, as well as culture and values. On the other hand, the readiness of external trading partners to adopt e-commerce will in no small measure determine institutionalisation of e-commerce in developing countries (Aziz, 2010; Solomon and Ajagbe, 2014). Hence, the necessity of business maturity regarding the readiness prior to e-commerce adoption in developing countries is important to be discussed.

Zhu and Thatcher (2010) reported that in a typical e-

commerce adoption model, perceived benefits, firm size and readiness and external and competitive pressures are important factors to consider. In addition, anticipated operational supports, cost reduction and social approval; and application complexity and providers' views are amongst the major factors. Abiso and Ajagbe (2018) found that though the aforementioned essential adoption motivators and/or barriers have an impact, studies and theories perceive management's characteristics and supports, owners' readiness and growth ambitions, managers knowledge and characteristics, managers' belief differences, and managerial productivity as significant adoption predictors of e-commerce solutions that must complement existing factors. Awa et al. (2015) observed that the adoption of e-commerce solutions depends on the functional and/or emotional feelings of decision makers, which reflect their attitudes, perceptions, psychographics and motivation. Kannabiran and Dharmalingam (2012) opined that entrepreneur or manager is essential for setting appropriate information communication technology goals, recognizing important information requirements, allocating resources, and managing executions. Considering the strengths of existing philosophies, entrepreneur's position and reposition firm's strategic thrusts (Awa et al., 2011; Abiso and Ajagbe, 2018). They drive e-commerce solutions by shaping values and cognitive bases of dominant actors, particularly if it is viewed to contribute to the operational efficiency (Sharma et al., 2013). In their survey of SMFs in Portuguese manufacturing industry, Zeiller and Schauer (2011) found that the opinion of senior managers and attitudes towards adoption of information communication technology explain various corporate success stories. They argued from resource-based points that SMFs develop internal skills, competences, and capabilities subject to senior manager's views and attitudes towards implementation of ICT. In view of this the major objective of this research is to find out the level of awareness and readiness of e-commerce technology adoption by SMFs in Borno state. However, the research question guiding this study is: What is the level of awareness and readiness of adoption of e-commerce technology and how is it been adopted among SMFs in Borno state?

3 METHODOLOGY

The philosophy of this research was selected because a review of past studies revealed the urge to have a deep knowledge of the experience of entrepreneurs in Borno state who have implemented e-commerce technology in their daily activities (Ajagbe, 2014; Ajagbe et al., 2015). Hence, this study used purposeful sampling and the case study as a reporting approach. The study adopted the organisational unit of analysis to determine the chosen sample population for the study. The triangulation strategy was adopted by gathering information with the adoption of several techniques. This study used an inductive qualitative strategy that consisted of an average of 65 minutes tape recorded discussions to obtain the perspectives of the SMF entrepreneurs about their awareness and readiness to adopt e-commerce technology in carrying out their busi-

ness transactions. The researchers randomly selected 25 informants from among SMFs registered in Borno state. Most of the SMFs were selected from Maiduguri city because of high rates of concentration of SMFs.

In order to present concepts or dimensions, data collected were transcribed and coded, and the investigator connected concept together into a theory, or explanation of the event studied. However, analyzing qualitative information entails having a vivid knowledge of how to make sense of text and images so that you can form answers to your research questions (Tesch, 1990). In the opinion of Creswell (2007), the qualitative study is an interpretative study, in which the researcher makes a personal evaluation as to an explanation that fits the situation or themes that capture the main themes of data. The interpretation that an author makes of a transcript, for instance, varies from that someone else makes. This does not mean that the interpretation of the first author is better or more accurate; Taylor et al. (2006) posited that it simply means that the author brings his own views to the interpretation. Nonetheless, in order to achieve the aim of this study, the authors used both "in vivo codes and lean codes". This is because it was sometimes found to be essential to use the codes exactly the same way the informants described during the interview. However, other situations could warrant the authors to rephrase the words in their own words. Table 1 showed the result of the coding process for the study.

Table 1: Result of the Coding Process

Major Emerging Codes	Sub-Codes	Coding Categories
Level of Awareness	6 Sub-Codes	95 Codes
Level of Readiness	5 Sub-Codes	121 Codes
2 Major Codes	11 Sub-Codes	216 Codes

4 RESPONDENT’S PROFILING

Analysis of the gender profile revealed that 06(24%) among 25 respondents are females while 19(76%) among 25 respondents are males. This is an indication that majority of the respondents interviewed are males. It could also mean that more males are involved in trading activities in Borno state. However, analysis of the educational profile revealed that 01(4%) among 25 respondents are master degree graduate, 09(36%) among 25 respondents have bachelor degree, 08(32%) among 25 respondents have OND/NCE and 07(28%) among 25 respondents have SSCE/PSLC. This indicated that majority of the respondents have requisite level of education to participate in the interview. However, analysis of the SMFs surveyed revealed that supermarkets consisting of 9 participants represents 36% of the participants of the study, restaurants consisting of 10 participants represents 40% of the participants of the study, boutique consisting of 4 participants represents 16% of the participants of the study and furniture consisting of 2 participants represents 8% of the total participants interviewed for the study.

4 ANALYSIS AND DISCUSSION

4.1 Emerging Themes from the Study

4.1.1 Level of Awareness to Adopt E-Commerce

Sharma et al. (2013) highlighted that e-commerce comprises of exchanges of information to the customers and suppliers, resulting to the process of selling and carrying out business transactions through online platforms. The findings from existing studies is in line with that of this study which examined the level of knowledge or rather awareness of entrepreneurial business owners as important ingredients of determining the implementation of e-commerce in Nigeria. However, in this study, e-commerce has been defined in various perspectives depending on the understanding of each individual. The concept of e-commerce was described as the use of more upgraded technological and electronic means to conduct business activities. In addition, it is the process by which businesses and consumers buy and sell goods through electronic platforms or medium. Simplistically put, e-commerce can also be viewed as cashless or rather electronic transactions or marketing. In another dimension, it can also be perceived as the process of engaging or using the internet to carry out business transactions. Respondent 10 who is an owner of a boutique described e-commerce as:

“process whereby you adopt technology in business, cashless or rather electronic transaction, use of internet, machine or electronic means to do business. It also involves the process by which businesses and consumers buy and sell goods through electronic medium”.

Though majority of respondents have described the concept of e-commerce based on their understanding, very few could not describe the term as reported in below quotation. As stated by RES 25 who owns a restaurant in the city:

“I am not educated, so I do not have any idea of that terminology, hence we don’t use technology in running our business activities”

This study found that the reason some SMF owners could not describe the term is due to their level of education and exposure. Abiso (2017) and Abiso and Ajagbe (2018) found that knowledge of entrepreneurial business owners and that of senior managers determine to a greater extent the extent or level of e-commerce implementation in Nigeria.

The table 2 below indicated that 18(72%) among 25 respondents mentioned that they are fully aware of the concept of e-commerce technology, 05(20%) among 25 respondents said that they are partially aware of the concept of e-commerce technology, while 02(05%) respondents posited that they are unaware of the meaning of e-commerce technology. This indicated that majority of the respondents of this study are fully aware of the concept of e-commerce technology and are qualified to participate in this research. Table 3 showed some examples of SMFs that adopt e-commerce in their organization. This study also listed some of the electronic gadgets used by interviewed respondents in their day to day transactions as; personal computer, point of sales machine, automated teller machines, mobile phone, internet connections.

Table 2: Level of Awareness of E-commerce

High Awareness	72%
Low Awareness	20%
Neutral	5%
	100%

Table 3: SMFs that Adopt Electronic Commerce

Type of SMFs	Name of SMFs
Supermarkets	Sidi Groceries and Prawns, Obynado Supermarket, Today Supermarket
Restaurants	Oasis Bakery, Mr. Biggs, Chicken Republic, Pinnacle Restuarants
Furniture	Allah Dey Furniture Works
Online Supermarkets	Jumia, Jiji, Konga,
Boutique	Amazing Royal Boutique
Hair Care Salon	AYB Hairdressing Salon

4.1.2 Readiness of SMFs to Adopt E-Commerce

Table 4 below indicated that 15(60%) among 25 respondents agreed that they are fully ready and are already implementing e-commerce technology, 07(28%) among 25 respondents mentioned that they are partially ready in implementing e-commerce technology, while 03(12%) respondents posited that they are not yet ready to implement e-commerce technology in their day to day business operation. The implication of this findings is that majority of the respondents of this study are fully ready and are implementing the use of e-commerce technology in conducting business transactions. This study also showed that adoption of e-commerce by SMFs depends on managements’ decision and readiness. Hence, organizational readiness was conceptualized as the knowledge, financial and technological capabilities at the disposal of the firm to adopt e-commerce technology (Saffu et al., 2011; Alawati et al., 2013). In addition, Ahn and Matsui (2011) argued that organizational readiness includes the interest of entrepreneurs to implement ICT, existing technology infrastructure, compatibility of the firm’s e-commerce, and culture and values. Table 4 showed the readiness of adoption of e-commerce technology among SMFs in Borno state. According to respondent 07:

“We are ready to implement e-commerce technology so as to bring up the name of the company and also partake in international trading i.e export of goods from one country to another”.

Table 4: Readiness of SMFs to Adopt E-Commerce

High Readiness	60%
Low Readiness	28%
Neutral	12%
	100%

5 CONCLUSIONS OF THE STUDY

The intention of this study is to understand the level of awareness and readiness of e-commerce technology adoption by SMFs in Borno state. This study observed that on the average entrepreneurs has a broad understanding of the concept of e-commerce. Hence, they have described the concept to mean the use of more upgraded technological and electronic means to conduct business activities. In addition, it is the process by which businesses and consumers buy and sell goods through electronic platforms or medium. On the readiness to adopt e-commerce among SMFs in Nigeria, this study found that many SMFs are already implementing e-commerce in their business operations, some are partially implementing it, while very few are not willing to adopt it. Hence, majority of SMFs are fully ready and are implementing the use of e-commerce technology in conducting business transactions. It was however, evident that managements’ decision and readiness is a major determinant of e-commerce adoption. The authors suggested that considering the numerous benefits accruable to firms adopting e-commerce and its contributions to national growth. Public policy makers are advised to introduce policies to encourage e-commerce adoption by firms particularly the small and medium sized firm’s sector. In addition, since management decisions and readiness influence e-commerce adoption, entrepreneurs are advised to be properly guided to improve their ICT knowledge as this will lighten their enthusiasm in experimenting e-commerce technology adoption in conducting their business transactions. Future authors are advised to further this research by expanding their data collection to customers and suppliers perspectives to e-commerce adoption by SMFs. Also themes that have emerged from this study could be quantitatively tested to determine the generalizability of findings from this study.

6 REFERENCES

- [1] Alatawi, F. M. H., Dwivedi, Y. K. and Williams, M. D. (2013). Developing a conceptual model for investigating adoption of knowledge management system in Saudi Arabian public sector’, International Journal of Business Information Systems, 14(2): 135–163.
- [2] Ahn, P. C. and Matsui, Y. (2011). “The relationship between quality management information and operational performance: international perspectives”, Management Research Review, 34(5): 519-40.
- [3] Ayo, C. K., Adewoye, J. O. and Oni, A. A. (2011). Business-to-consumer e-commerce in Nigeria: Prospects and challenges. African Journal of Business Management, 5(13): 5109-5117.
- [4] Ajagbe, A. M. (2014). Funding Criteria in Technology Based Firms. An Unpublished Thesis submitted to Universiti Teknologi Malaysia in partial Fulfilment of award of Doctoral Degree in Management.
- [5] Ajagbe, A. M., Isiauwe, T. D., Sholanke, B. A. and Oke, A. O. (2015). Qualitative Inquiry for Social Sciences. In the Proceedings of the Covenant University

- International Conference on African Development Issues (CU-ICADI 2015) held on 11-13th May, pp. 319-325.
- [6] Abiso, A. K. (2017). Electronic Commerce Technology Adoption among Small and Medium Sized Firms in Nigeria. PhD Thesis submitted to Graduate School, Oxford University, Namibia.
- [7] Abiso, K. A. and Ajagbe, A. M. (2018). Adoption of Electronic Commerce Technology in Emerging Nations: A Conceptual Review of the Literature. *International Journal of Economics, Commerce and Management, UK.*, VI(2): 455-472.
- [8] Awa, O. H., Ojiabo, U. O. and Emecheta, C. B. (2015). Integrating TAM, TPB and TOE frameworks and expanding their characteristic constructs for e-commerce adoption by SMFs. *Journal of Science & Technology Policy Management*, 6(1): 76-94.
- [9] Agwu, M. E. and Murray, J. P. (2015). Empirical Study of Barriers to Electronic Commerce Adoption by Small and Medium Scale Businesses in Nigeria. *International Journal of Innovation in the Digital Economy*, 6(2): 1-19.
- [10] Creswell, J. W. (2007). "Qualitative inquiry and research design: Choosing among five approaches" 2nd ed. Thousand Oaks: Sage Publications, 127-147.
- [11] Dahnil, I. M., Kamarul, M. M., Langgat, J. and Fabeil, F. (2014). Factors Influencing SMFs Adoption of Social Media Marketing. *Procedia - Social and Behavioral Sciences*, 148, 119-126.
- [12] Jamali, S. K., Samadi, B. and Gharleghi, B. (2015). Factors Influencing Electronic Commerce Adoption: A Case Study of Iranian Family SMFs. *International Journal of Business and Social Science*, 6(2): 178-199.
- [13] Kannabiran, G. and Dharmalingam, P. (2012). Enablers and inhibitors of advanced information technologies adoption by SMFs: an empirical study of auto ancillaries in India. *Journal of Enterprise Information Management*, 25(2): 186-209.
- [14] Oluyinka, S., Shamsuddin, A., Wahab, E., Ajagbe, A. M. and Imodu, W. (2014). A study of electronic commerce adoption factors in Nigeria. *International Journal of Information Systems and Change Management*, 6(14): 293-314.
- [15] OECD. (2009). Top Barriers and Drivers to SME Internationalisation. OECD, Report by the Working Party on SMEs and Entrepreneurship.
- [16] Olatokun, W. and Kebonye, M. (2010). E-commerce Technology Adoption by SMFs in Botswana. *International Journal of Emerging Technologies and Society*, 8(1): 42-56.
- [17] Solomon, O. and Ajagbe, A. M. (2014). Internet Banking Adoption in Nigeria: A Literature Review. 2014 International Conference on Computer, Intelligent Computing and Education Technology, March 28th, Hong Kong.
- [18] Saffu, K., Walker, J. H. and Mazurek, M. (2012). Perceived Strategic Value and e-Commerce Adoption among SMFs in Slovakia. *Journal of Internet Commerce*, 11(1): 1-23.
- [19] Tesch, R. (1990). "Qualitative Research: Analysis Types and Software Tools" Bristol, PA: Falmer Press.
- [20] Taylor, B., Sinha, G. and Ghoshal, T. (2006). "Research Methodology: A Guide for Researchers in Management and Social Sciences." (Eastern Economy Ed), New Delhi: Prentice-Hall.
- [21] Usoro, A. (2010). Task-Technology Fit and Technology Acceptance Models Applicability to e-Tourism. *Journal of Economic Development Management, Information Technology, Financial Market*, 2(1): 1-32.
- [22] Ukoha, O., Awa, H., Nwuche, C. and Asiegbu, I. (2011), "Analysis of explanatory and predictive architectures and the relevance in explaining the adoption of IT in SMFs", *Interdisciplinary Journal of Information, Knowledge and Management*, 6, 216-229.
- [23] Voges, K. and Pulakanam, V. (2011). Enabling factors influencing Internet adoption by New Zealand small and medium size retail enterprises. *International Review of Business Research Papers*, 7(1): 106-117.
- [24] Zhu, L. and Thatcher, J. (2010). National information ecology: A new institutional economics perspective on global e-commerce adoptions. *Journal of Electronic Commerce Research*, 11(1): 53-72.

Monetary Policy and Commercial Bank's Lending Ability Nexus: The Case of Selected Banks in Nigeria

Alex Ehimare. Omankhanlen^{*}, Esangaya Mengot and Olaide Kehinde

Department of Banking and Finance; Covenant University, Ogun State, Nigeria.

[*alexander.omankhanlen@covenantuniversity.edu.ng](mailto:alexander.omankhanlen@covenantuniversity.edu.ng)

Abstract—Monetary policy has been set up by government to regulate and measure the activities of commercial banks. The main objective of this study is to examine the relationship between monetary policy and commercial banks' lending ability. For data analysis, the ordinary least square, unit root test, Johansen test for co-integration and VAR were used. The findings revealed that there is a relationship between monetary policy and bank lending in the economy. It is recommended that the reserve requirement be reduced in order to make more money available for banks to give out as credit to the investors.

Keyword— Loans; Advances; Monetary Policy; Savings and Banks lending.

1 INTRODUCTION

Monetary policy refers to the aggregate of discretionary measures intended to regulate and control the money supply in an economy by the monetary authorities with the perspective of attaining identified or aimed macro-economic goals. In the Nigeria economy today monetary policy is the major tool embraced by the government to guarantee total economic growth and advancement in order to accomplish specific predetermined macroeconomic goals. Monetary policy creates the major policy thrust of the government in the realization of various macro-economic objectives. Since the late 1980's monetary policy has become a major policy instrument in Nigeria, throughout this period CBN's monetary policies focused on fixing and controlling interest rates and exchange rates, sectorial credit allocation, maneuvering of the discount rate and involving moral suasion (Omankhanlen 2011).

Lending which may be on short, medium or long-term basis is one of the services that commercial banks do provide to their customers. In other words, banks do grant loans and advances to individuals, business organizations as well as government in order to enable them set out on investment and development activities as a method of assisting their growth in particular or adding toward the economic improvement of a country in general. Commercial banks are the most vital savings mobilization and financial resource allocation institutions. Subsequently, these responsibilities make them important institutions in economic growth and development.

1.1 Statement of the Research Problem

One of the most difficult matters facing government is recognizing the applicable level and form of intervention in

the banking sector. Its efficiency as a regulator is a significant determinant of the overall efficiency of the economy. The level of regulatory interference may also establish whether financial markets can develop to their full potential or not. Ultimately, any inefficiency must be funded by higher charges passed on to the economy as cost arising from stringent regulation. The more sophisticated the monetary policy, the greater its exposure to failure of banks to deliver against its promises (Udeh 2015). According to Omankhanlen (2014) The Nigerian banking system can be said to be the one that does the essential role of aiding monetary policy implementation and facilitating the role of financial intermediation in the economy. Therefore, since the introduction of monetary policy it has been noticed that policies implemented by the monetary authorities has not been effective on the deposit bank lending ability which has reduced the performance of the bank within the financial system and their profitability.

1.2 Objectives of the Study

The main objective of this research work is to establish the impact of monetary policy on commercial banks' lending ability to the economy. The sub-objectives are as follows:

- i. To determine how money supply (M^2) affects commercial bank lending ability in the economy.
- ii. To determine how interest rate affects commercial bank lending ability in the economy.
- iii. To determine how cash reserve ratio affects commercial bank lending ability in the economy.

The research questions and hypotheses are drawn from the above objectives.

1.3 Scope of the Study

This scope of study will cover the period 1983-2016 that is

34 years in Nigeria. The data that will be used in this study will be secondary data. This study will focus on the performance of money supply, interest rate and cash ratio on lending of commercial banks in the economy.

1.4 Limitations On Bank Lending

The following are the factors that cause a constraint on commercial banks ability to lend to the economy:

i. Liquidity

One of the greatest essential tasks faced by the management of commercial banks is ensuring sufficient liquidity. A bank is measured liquid if it has prepared access to instantly spendable funds at a rational cost at exactly the time the funds are required. This is stable with the results of Kashyap and Stein (2000) that banks amend their liquidity according to their recent investment opportunities, increasing liquidity when lending opportunities are poor and decreasing liquidity when lending opportunities improve. It should be noted that improved bank profits will re-enforce further bank loans and investments that further increases bank profits to ideal level. Insufficient liquidity is often one of the first signs that a bank is in serious financial trouble. (Uremadu, 2012). The exact bank in question usually begins to lose deposits as persons out of fear withdraw their deposits from the bank; this erodes its supply of cash and forces the institution to dispose of its more liquid assets.

ii. Operational Orientation

Medium to long-term loans tenors for loan facilities remain a worrying some of investment risk for most banks in the emerging markets. For this category of loans the major cause of risk is the term structure of the deposit liabilities of these banks. On this count, banks operating in the emerging markets are mostly disadvantaged; they often rely on short-term funds or usually find it hard to attract long-term deposits to fund term loans.

In most cases, the incapability of the banks to invite long-term deposits is due to recurring unfavourable macro-economic issues, which make long-term financial planning almost practically impossible for most economic units.

And lastly, **Flaws in the Legal System**

2 RESEARCH METHODS

For this study secondary data gotten from Central Bank of Nigeria (CBN), Statistical Bulletins and World Development indicator covering the periods of 1983 to 2016 will be used. This study will make use of Johansen co-integration analysis to investigate the effectiveness of money supply, interest rate and cash reserve ratio on the lending ability of the commercial banks to the economy. This analysis will be based on annual data; (E Views 5.0) will be applied in the data analysis where the lending will be the dependant variable and money supply, interest rate and liquidity ratio as independent variable.

2.1 Model Specification

The model for this study is specified below

$$DMBLA = b_0 + b_1M^2 + b_2INTR + b_3CRR + u_i \quad (1)$$

DMBLA= Commercial banks loans and advances

M²= Money supply

INTR= Interest rate

CRR= Cash reserve ratio

Where the dependent variable is commercial banks loans and advances while independent is M², interest rate and cash reserve ratio.

2.2 Technique of Estimation

To analyze the model represented above the ordinary least square method (OLS) will be used in addition to unit root test, Johansen test for co-integration and vector error correction model

2.3 Measurement of Variables

In this study, commercial banks' lending is proxied by the commercial banks loans and advances (DMBLA) while the monetary variables using M², interest rate and cash reserve ratio

3 EMPIRICAL ANALYSIS AND RESULTS

Introduction

This research work is primarily interested in finding out the relevance of selected monetary policy indicators in predicting the trends of banks' lending in Nigeria from the period of 1983 to 2016. This estimation was done using E-views7.0. The empirical study is based on annual data from the Central Bank of Nigeria, (CBN,) Statistical Bulletin.

3.1 Econometric Analysis

Unit root test

The section examines the unit root property of the variables in the model. This study utilized Philips-Perron (PP, 1998) unit root tests with the inclusion of intercepts components in the test.

Table 4.1: A Table showing the Unit Root Test Results

1 st Difference		Levels				
Variables	PP-Stats	Critical Value at 5%	Remarks	PP-Statistic	Critical Value at 5%	Remarks
LLAD VS	-5.14	-2.95	S	0.13	-2.95	N S
LM ₂	0.12	-2.95	S	0.12	-2.95	N S
LINTR	-2.30	-2.95	S	-2.30	-2.95	N S

LCRR	-	-2.95	S	-2.11	-2.95	N S
	2.1					
	1					

Source: Author's Compilation from E-views 7.0

Note: A variable is stationary when PP value is greater than the critical value.

¹LLADVS- Log of loans and advances

²LM2- log of broad money supply

³LINTR- log of interest rates

⁴LCRR- log of cash reserve ratio

⁵S- Stationary

⁶N S- Non Stationary

The results are displayed in Table 1. The test statistics for the log levels of loan and advances, broad money supply, interest rate and cash reserve ratio are statistically insignificant. This shows the null hypothesis of a unit root present among the series cannot be rejected at levels for all the variables. Hence, this study further applies the unit root tests to the first difference of all the variables. A stationary series was obtained for all the variables at first difference. The PP test rejects the joint unit root null hypothesis for each variable at the 5 per cent level. Thus, from the result of the tests, the unit roots tests indicate that each variable is integrated of order one process. The evidence of an integrated series is further subjected to long run relationship test using Johansen co integration approach as shown in the subsequent table below;

2 Co integration test

Table 2': A Table showing Unrestricted Co integration Rank test

Hypothesized No. Of CE(s)	Eigen value	Trace Statistic	0.05 Critical Value	Prob.**
None*	0.525201	50.27814	47.85613	0.0291
At most 1	0.388413	26.44248	29.79707	0.1160
At most 2	0.258967	10.70815	15.49471	0.2301
At most 3	0.034317	1.117423	3.841466	0.2905

Source: Author's compilation from eviews 7.0

Table 3': A Table showing Unrestricted Co integration Rank test

Hypothesized No. Of CE(s)	Max-Eigen Statistics	0.05 Critical Value	Prob.**
None	23.83566	27.58434	0.1406
At most 1	15.73433	21.13162	0.2408
At most 2	9.590729	14.26460	0.2402
At most 3	1.117423	3.841466	0.2905

Source: Author's compilation from eviews 7.0

Generally, the existence of co integration signifies that there is at least one long-run equilibrium relationship among the variables. In this case, Granger causality exists among these variables in at least one way (Engle and Granger, 1987). The results of the long-run equilibrium relationship are presented in table 2 and 3 above. It shows that there exist at least one co integrating equation among the variables in the model. This conclusi

on is reached by comparing the maximum Eigen value and trace statistics with their corresponding critical values. An Eigen value or trace statistics greater than the critical value indicates a co integrated series. As shown in table 2 and 3 the trace statistics indicates the presence one co integrating equation at 5 percent level of significance. This further reveals the existence of a long-run equilibrium relationship among the variables estimated for the commercial banks' lending.

The VECM is used to correct the disequilibrium in the long run co integration relationship. It also tests for long and short-run causality among co integrated variables. The correction of the disequilibrium is achieved by the mean of the Error correction term (ECT).

Table 4: Normalized co integrating relationship

Normalized co integrating coefficients (Standard error in parenthesis)			
LLADVS ¹	LM2 ²	LINTR ³	LCRR ⁴
1.000000	1.093530	0.485198	- 0.110367
	(0.02379)	(0.22387)	(-0.07439)
	[45.9659521]	[2.1673203]	[-1.4836268]

Source: Author's Compilation from E-views 7.0

Note: Standard error and T-statistics are stated in parenthesis as () and [] respectively

Table.4 shows result of the normalized co integration coefficients of the variables for the instance when there is at least one co integration equation as affirmed from table 4 with the trace statistics. The results in the table 4. are explained in regard to the inverse signs and magnitude of the variables in the normalized co integration result. The probability value of the T-statistic is used to indicate the significance or otherwise of the independent variable in the long run equation. Generally using the rule of thumb if the T-Statistics is 2 or greater than two, the variable is significant but if the reverse is the case then it is insignificant.

The result of the normalized co integrated relationship reveals a significant relationship between broad money supply, interest rate and banks' loan and advances while cash reserve apparently reveals a less significant influence on commercial banks' loan and advances within the scope of this study.

Specifically, the result from table 4 shows a significant relationship between money supply and banks lending at 1 percent level of significance. This further reveals that a percentage change in exchange results to a corresponding 1.094 percent change in lending. The analysis of the result shows a proportionate change in money supply leads to a more proportionate change in banks' loan and advances holding other variables at a constant. The evidence from the elasticity estimate reveals that the degree of respon-

siveness of banks' lending to the variations in money supply is greater than one and therefore elastic. This further shows that money supply plays a significant role in determining the banks' lending in Nigeria. Hence in regard to the first objective of this study which is to determine how M₂ affects commercial banks' lending ability in the economy, it is observed that a percentage increase in money supply significantly increases commercial banks' lending by 1.094 percent at 1 percent significance level. Therefore the null hypothesis that M₂ has no significant impact on the influence of commercial banks' lending ability in the economy could be accepted by this study leading to the acceptance of the alternative hypothesis that M₂ has a significant impact on the influence of commercial banks' lending ability in the economy.

The analysis of the estimated long run co efficient of interest reveals a significant long run relationship with banks' lending at 5 percent level of significance. A percentage change in interest rate indicates 0.485 percentage change in banks' loan and advances, all things being equal. The above evidence further reveals that a proportionate change in interest rate results to a less proportionate change in commercial banks' lending. It therefore implies that the degree of the responsiveness of banks' lending to the changes in interest rate is less than unit elasticity and thus inelastic. In respect to the second objective of the present study to determine how interest rate affects commercial bank lending ability in the economy, the evidence from the study shows there existence of a significant direct effect of interest rate on commercial banks' lending ability.

Vector Error Correction

The vector error correction model shows the short run dynamics between the variables in the co integration equation estimating the error correction. Table 4 shows the estimated coefficients for the error correction term based on the normalized commercial banks' loan and advances model.

From table 4 the result shows that the coefficient of the estimated banks' lending error correction result. The result of the error correction term as expected is negative and lies between zero and one and it is also significant at 5 percent level. The significance of the error correction model agrees with the co integration and gives the opinion that there is long run steady-state equilibrium between the level of share price index and the explanatory variables; exchange rate, inflation rate, interest rate and gross domestic product and oil prices.

Table 5: A Table showing the Vector Error Correction Estimates

Variable	D(LLADVS)	D(LM2)	D(LINTR)	D(LCRR)
ECM (-1)	-0.858816	0.161974	0.854438	-1.501539
Standard Error	(0.31502)	(0.18307)	(0.23490)	(0.88093)

T-Statistic	[-2.72624]	[0.88478]	[3.63753]	[- 1.70450]
-------------	------------	------------	------------	-------------

Source: Author's Compilation from E-views 7.0. Standard error and T-statistics are stated in parenthesis as () and [] respectively.

The table above indicates that estimated lagged error correction term for commercial bank lending model. The magnitude of the error correction term is negative and appropriately signed, its absolute value lies between zero and one, and it's statistically significant. This suggests a long-run convergence of the model; it therefore implies that if any external shock is introduced into the model, the model would still converge back its equilibrium state with time. Evidence from result of the error correction estimate shows a relatively high speed of error adjustment of the model at 0.8588, this implies that 85.88 percent of current error in the model arising from exogenous shocks on the system would be corrected in the short run adjustment mechanism. These indicate that whenever there is the presence of external shock resulting to disequilibrium of the system, the system could easily make short-run adjustments to re-establish long-run equilibrium given the high speed of adjustment from the short-run to the long-run equilibrium at 85.88 percent per time.

4 RESEARCH FINDINGS, RECOMMENDATION AND CONCLUSION

From the research findings it was confirmed that there is a relationship between monetary policy and bank lending as explained below.

1. Money supply (M²) has a significant relationship which means is one of the major determinant of bank lending, an increase in money supply to the economy leads to more proportionate change in bank lending. Cash reserve ratio shows an insignificant relationship it implies that it does not have an effect on bank lending rate. In signs and magnitude it shows an inverse relationship with lending rate which shows an increase in cash reserve ratio would result to a decline in bank's lending capacity.
2. The positive relationship between interest rate (lending rate) and commercial banks loans and advances has implications to the bank. If the lending interest rate is high as been determined by the bank the public will not be encouraged to borrow from the bank this will lead to a decline in the bank lending to the public.
3. The negative relationship between cash reserve ratio and commercial banks loans and advances has implications to the lending ability of the bank to the economy. The positive effect occurs only when the regulatory authorities reduces the cash reserve ratio set for the bank there will be enough funds which could encourage the bank to lend out to the economy, while the negative effect is when the cash reserve ratio set by the central bank is high and the bank is expected to meet up it the rate at which the banks would

lend out will be reduced therefore, affecting the lending ability of the bank negatively.

Sciences, 98-113

4.1. RECOMMENDATIONS

The recommendations from the findings are as follows:

1. It is recommended that government should put in place stringent rules and measures for M² to increase lending through open market operations (OMO) by purchasing of government securities such as treasury bill, treasury bonds etc. so there will be money available for lending and this will reduce the lending interest rate so that it will be easier for customers to assess loans from the bank for investment purposes.
2. The Central Bank of Nigeria should implement cash reserve ratio efficiently by increasing or reducing it as the economic parameters show. to boost lending and borrowing by investors.

4.2 CONCLUSION

From the research findings it can be concluded that there is a relationship between monetary policy and bank lending and is one of the major factor that influences bank lending to customers.

ACKNOWLEDGEMENT:

This Research Was Supported By Covenant University Ota, Ogun State, Nigeria.

REFERENCES

- [1] Engle.R. and Granger.C. (1987) "Co-integration and Error Correction: Representation, Estimation and Testing". *Econometrica Vol 55, Issue 2, pp.251-276*
- [2] Kashyap A.K and Stein J.C (2000)" What do a Million observations on Banks say about the transmission of monetary policy?" *American Economic Review 90 (June); 407-428*
- [3] Omankhanlen A.E (2011) "The Effectiveness of Monetary Policy in Achieving Economic Growth: the Case of Nigeria 1980-2009". *Euroeconomica, Vol. 29, No 3.*
- [4] Omankhanlen A.E (2014) "The Effect of Monetary Policy on The Deposit Money Bank System .International Journal of Sustainable Economies Management.3 (1) pp 39-51
- [5] Udeh (2015) "Impact of Monetary Policy Instruments on Profitability of Commercial Banks in Nigeria: Zenith Bank Experience". *Research Journal of Finance and Accounting Vol. 6, No 10, pp 192-193.*
- [6] Uremadu, S.O. (2012) "Bank Capital Structure, Liquidity and Profitability Evidence from Nigeria Banking System". *International Journal of Academic Research in Accounting, Finance and Management*

A Critical Review of the Relationship between Merger and Acquisitions and Firm's Performance: The Moderation Effect of Corporate Governance

Umar Muhammed Dikko^{1*}, Mohd Norfian Alifiah¹, Ibrahim Danjuma Yahaya²

¹Faculty of management, Universiti Teknologi Malaysia, Johor, Malaysia.

²Career Information & Resources Centre, Minna, Niger State, Nigeria.

*mahdikko@gmail.com

Abstract— The purpose of this paper is to evaluate the existing studies on the relationship between merger and acquisition with firm's financial performance by using corporate governance as a moderator and address the need for similar analysis by analyzing merger and acquisition with firm's performance in both developed and developing economies. The existing studies that measure the relationship between merger and acquisitions with performance in both developed and developing economies are found to be inconclusive and inconsistent in nature because of contradictory results in their findings. As a result of inconsistency and contradiction in previous literature, this study propose the need by introduce the corporate governance as a moderator between merger and acquisitions with firm's performance.

Keywords- Board of Directors, Corporate Governance, Firm performance, Merger & Acquisition.

1 INTRODUCTION

Numerous researchers analyze the relationship of merger and acquisition with firm's performance in developed economy (DE) and emerging economy (EE)(Alexandrou, Gounopoulos, & Thomas, 2014; Aybar & Ficici, 2009; Bertrand & Betschinger, 2012; Cortés, García, & Agudelo, 2015; Christine & Jagongo, 2018; Liao & Williams, 2008; Nicholson & Salaber, 2013; Sumon, Kumar, Bhaumik, & Selarka, 2012; Slovin, Sushka, & Hudson, 1991; Singal, 1996; Tao, Liu, Gao, & Xia, 2017; Weinberg, 1979). Interestingly, the importance of merger and acquisition and how it affects the level of firm's performance in DE and EE have been driving the attention of many scholars [23]. According to Lebedev et al., (2015) there are some significant differences in DE and EE, such as corporate governance practice, institutional background and market structure that lead to the different measure of M&As with firm's performance. Bastomi et al. (2017) described corporate governance as a set of relationships between the company's management, boards and shareholders and others who have an interest in the company by setting rules that resolve the potential conflict between managers and shareholders of a company.

Many researchers have focused on performance of M&As in both developed and developing economy and found the mixed results, for instance (Aybar & Ficici, 2009) [14] in their study found Negative, Sumon et al., (2012); Chari et al. (2010); Chi et al. (2011) Gubbi et al. (2010) [18]. Due to inconsistency in the previous literature, however this study will address the literature gap by introducing the corporate governance as a moderator (Baron & Kenny, 1986; Rezaul Kabir, 2017; Hair, Hult, & Ringle, 2017). Next

section will discuss literature review, section 3 reveal the critical analysis and inconsistency in the previous literature of performance of M&As in both DE and EE. While section 5 discusses the theories and motivation of M&As, conclusion and suggestion for future research will follow in the final section.

This review specifically intends to evaluate theoretical and empirical literature related to M&As and financial performance with the moderation effect of corporate governance respectively, with a view of establishing areas of gaps for future research in both theoretical and methodological. Furthermore, it highlights the importance of more quantitative methods for in-depth understanding of the relationship between the three variables under review.

2 LITERATURE REVIEW

Mergers has been defined as strategic and economic reasons that two or more companies come together to form a bigger company while acquisition entails a buy-over of one or more companies usually by a larger company (Aduloju, Awoponle, & Oke, 2008).

The importance of M&As has been identified in the previous literature. Some of these literatures found that M&As may increase efficiency [30] improve market power [31] enhance the management of resource over dependency (Piskorski, 2005; Pfeffer, 1972) reduce transaction costs [34] and operating costs [35].

2.1 Concept of Firm's Financial Performance and Corporate Governance

2.1 Firm's Financial Performance

Performance of an organization can be identified in many ways. For instance, Antony and Bhattacharyya (2010) defined performance as those measure that is used to assess and evaluate the achievement of an organization to generate and deliver value to its external as well as internal customers. Performance can be measured on how well a firm can use their assets to generate revenue from their primary mode of operation [37]. Moreover, AbdulRasheed et al. (2012) sees performance as the capacity of firm's to maximize returns on investor's funds.

It can also be referred to output achieved from the firm's objectives through management operations [39]. Furthermore, Simons (2013) defined firm performance as a company's activities interacting with different market mechanisms (financial factors and customers). In the financial market, potential investors, creditors, and stockholders should be satisfied with performance of the company using financial indicators (Hoque, 2004).

Some view performance from objective measures (financial) that comprises the use of a set of financial ratios or volume measures, with the most common indicators being annual profit, return on investment and revenue growth (Henri, 2004; Hoque, 2004). In addition, Neely (2007) reported that there is numerous financial measures but mostly used include return on equity (ROE), return on assets (ROA), return on investment (ROI), value per employee, earnings per share and profit margin.

Financial performance is a measure of company's operations and policies in relation to monetary, these results are reflected in the firm's return on assets, return on investment, capital base, value added, employee's performance and customer loyalty [44], [45]. Financial performance measures are useful in furnishing financial information to their users for the assessment of the organization's efficiency and effectiveness. Financial performance measures include return on net assets, branch profit and revenue growth [46].

According to Chibueze, Maxwell, and Osondu (2013) stock prices and its behavior reflect the performance of a firm. However, it was reported that volume of deposit, size of the firm, and its profitability could be deemed as more reliable indicators of firm's performance [48]. Profit growth, sales growth, and response to competition are also used in measuring financial performance by Bontis, Keow, and Richardson, (2000). Hamann, Schiemann, Bellora, and Guenther (2013) measured financial performance of an organisation through the use of stock market performance and accounting returns which comprise profitability and liquidity. It was also revealed by Murphy, Trailer, and Hill (1996) that profit efficiency and growth are the most frequently considered dimensions in measuring the firm's performance. However, Jha and Hui

(2012) measured performance of a firm by using return on assets (ROA) and return on equity (ROE). Similarly, financial performance of a firm are also measured by growth in deposit accounts, profit growth, ROA and balance sheet strength. Further more, the authours stress that they are most affected by fraud (Njenga & Osiemo, 2013).

2.2 Corporate Governance

Corporate governance has recently attracted more attention from academic and regulators around the world. The purpose of the corporate governance is design to make sure managers will act to the shareholder's interests [24]. The behavior of managers and firms owners became a major factor that needs attention in the implementation of corporate governance showed that improving the implementation of corporate governance can reduce credit risk and operational risk and increased financial performance [24]. The global financial crisis experience has prompted the necessity for increased effectiveness of corporate governance implementation.

Various definations has been provided by the previous researchers. For instance, Bastomi et al. (2017) defined corporate governance as a set of relationships between the company's shareholders, management, boards and others who have an interest in the company by setting rules that resolve the potential conflict between managers and shareholders of a company.

2.3 Empirical Studies on Merger and Acquisition and Performance

The review and findings on both M&As related to performance from the previous literature in developed and developing countries appeared to be mixed. The results shows that, returns can either be positive, negative or no relationship [23]. Aybar and Ficici, (2009) examined the returns of emerging multinationals in the analysis of 433 M&As between the period of 1991 to 2004 and the result shows that, the private ownership of the target, relative size of the target and diversification bids are found positively associated with abnormal returns. Additionally, according to Bertrand and Betschinger (2012) when analyzing the profitability of Russian firms also reported that M&A reduced the acquiring firm's performance and industry concentration has positively moderates performance of M&As.

Sumon, Kumar, Bhaumik, and Selarka, (2012) also revealed that, acquisitions made by Indian firms between 1995 to 2004 was mainly on concentrated ownership, and these findings indicate that, larger ownership concentration of an acquirer's management and foreign ownership increase acquisition's performance positively.

According to Chari, Ouim, and Tesar (2010), analyzing the performance of M&As deals from 1986 to 2006 also reported a positive and significant return of a firm for de-

veloped economy acquiring in emerging economy. In 2000 to 2007 the performance of acquisitions made by Indian firms reported that, there is a positive relationship between performance and M&As which lead to the increase in shareholder value in EE (Chi, Sun, & Young, 2011). Gubbi, Aulakh, Ray, & Chittoor, 2010). Bhagat, Malhotra, and Zhu, (2011) also report positive return on acquirers from EE and the majority of target firms are from DE but also suggested that, the performance is found to be positively correlated with the quality of corporate governance in a host country.

However, Liao and Williams (2008) reported that, acquirers from DE lead to a higher increase in labor and productivity compared to domestic acquiring firms and acquirers from both DE and EE also lead to an increase in profits of a target firms more than domestic acquirers. However, they also revealed that, performance was neither positive nor negative on the M&As.

2.4 Inconsistency in the Literature

Many researchers have focused on the performance of M&As in both developed and developing economy and found the mixed results, for instance Bertrand & Betschinger, 2012) in his empirical study found Negative, Bhagat et al., 2011; Chi et al. 2011; Sumon et al., 2012) and [18] found a Positive relationship while Liao and Williams (2008) after empirical study they found no relationship. Due to inconsistency in the previous literature. However, this study will address the literature gap by introducing the corporate governance as a moderator in order to address this inconsistency in the literature.

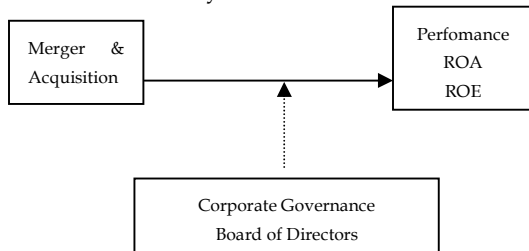

Figure 1.1 The conceptual framework of merger and acquisition and performance with moderation effect of corporate governance

3 CRITICAL ANALYSIS AND INCONSISTENCY IN THE PREVIOUS LITERATURE OF PERFORMANCE OF M&AS IN BOTH DE AND EE.

Weinberg (1979) conducted an empirical study on alternatives for restructuring the railroads for parallel mergers in USA. The study used 221 Railroad Transportation Company between the period of 1967 to 1971 and found that the horizontal mergers achieve higher gains in market share than vertical or mixed transactions. Market shares reflect the underlying cost, service quality

improvements, merger-related cost savings, performance enhanced positively in terminal operations and overshadow those in line-haul operations.

Slovin et al., (1991) investigated the effect of deregulation, contestability and airline acquisitions in USA. The study used the data 42 air transportation in USA between 1965 to 1988 and found that the shareholder of acquiring and target firms had a significant positive abnormal returns. However, abnormal returns for acquiring firms decrease and abnormal returns for target firms increase after deregulation while firms earn positive average abnormal returns for transactions with nontrivial changes in industry concentration, but after deregulation, transactions have no significant valuation effects on rival firms.

Singal (1996) investigated 42 airline mergers in USA between 1985 to 1988 and found that the acquiring and target firms earn significantly positive abnormal returns in contrast to rival firms' stockholders that on average neither benefit nor lose from transactions due to contradictory effects of more efficient operations and less competition. Samitas and Kenourgios (2007) investigated the tramp shipping firm's stock returns when they announced M&As of 15 water transportation companies in USA. The empirical study found that the abnormal return was significant and positive after the announcement of the M&As and remains stable especially for the tramp shipping firms that do not serve standardized routes but announcement of transactions have a direct positive impact on stock value.

Darkow, Kaup, and Schiereck, (2008) investigated the value implication of 200 logistics M&A that have taken place between 1991 to 2006 in Freight transportation company and found that Cross-border transactions generate significantly higher returns than national ones and transactions with large volumes appear more successful than smaller ones whereas the positive abnormal returns for shareholders of acquirer firms, target firms and the combined entity appears to be found. Transactions with large volumes appeared more successful than smaller ones whereas the positive abnormal returns for shareholders of acquirer firms, target firms and the combined entity appears to be found. Liao and Williams, (2008) An empirical study conducted between 1998 to 2005 and identified 74 cross-border M&A transactions in which international banks acquired ownership stakes in 46 listed banks in emerging market economies and found that the situations was sensitive to the nationality of acquiring banks. The results are not consistent across every window length which make the result of M&As neither positive nor negative.

Chari and Tesar, (2010) investigated public and private M&As in 1986 to 2006 developed market acquirer's experienced positive and significant abnormal returns of 1.16% on average over a three day event window. Moreover, the

positive acquirer returns and dollar value gains appeared to be unique to emerging market M&A. The greater in lack of equality between DE and emerging market organizations the higher the positive acquirer's returns for DE. Kammlott and Schiereck, (2011) investigated a M&As of 213 Water Transportation company and used the data between 1980 to 2007 and found a negative abnormal returns for the acquirers' shareholders but shows a positive abnormal returns for the targets' shareholders. Transnational transactions exhibit significant negative abnormal returns for acquirers with regional differences while European transactions are evaluated more significant successful than those from Asia. Andreou, Louca, and Panayides, (2012) investigated and found a positive deal value accrues mostly to targets shareholders rather than to acquirers shareholders. Acquirer returns are positively influenced by friendly transactions.

Bertrand and Betschinger, (2012) based on a sample of 600 acquirers showed that both domestic and international acquisitions tend to reduce the performance of acquirers compared to non-acquiring firms and the result indicated that, there is a negative effects associated with acquisitions. However, the firm resources are relevance and can be leveraged in domestic deals to improve the impact of acquisitions and there is no indication that, agency problems are the driving factor of the negative effect in long term performance of acquisitions. Nicholson and Salaber, (2013) this study investigated the cross border acquisitions using and the result showed that the acquirers from both countries gain more abnormal returns if the target firm is situated in a developed nation. Moreover, developed markets have more advanced tangible and intangible resources and reliable institutional rules to enjoy the advantages and increase the value of their shareholders in cross border acquisitions. Alexandrou et al., (2014) results showed a positive abnormal returns for both shareholders of acquirer firms and shareholder of target firms. Moreover, acquirers' shareholder gains significantly across maritime sectors and regions but are generally driven by higher acquirer profitability, smaller acquirer size, stock financing and cross border deals.

Cortés et al., (2015) the target firms realize significant positive abnormal returns especially in cases where transactions are considered to be strategic and the shareholders expect the integration to create substantial synergies. However, acquirers' shareholders do not realize significant abnormal changes in stock returns around the transaction announcement. Tao et al., (2017) this study investigated 165 listed Chinese firms between 2000 to 2012 and the study found that, on average, cross-border M&As by Chinese listed firms produced a positive market reaction by producing positive abnormal returns to shareholdings of acquiring firms. Christine and Jagongo, (2018) studied the M&As of 9 commercial bank in Kenya by using the data of 2010 to 2017 and found that the

operational synergy, differential efficiency, risk diversification and market share development as indicators of M&A have a positive significant influence on the financial performance of commercial banks in Kenya. The variables explained 98.2% of the changes in financial performance of the commercial banks.

4 THE THEORIES AND MOTIVATION OF MERGER AND ACQUISITIONS

Some theories advanced to justify the impact of M&As and can be classified in to value increasing theory and value decreasing theory. Value increasing theory explained that mergers occurs simply to generate synergy between acquired and target which in turn increase performance of the firms. Examples of these theories are the financial synergy theory, differential efficiency theory and Hubris theory while value decreasing theory predict that merger may fail to create value [63].

4.1 Financial Synergy Theory

This theory is a combination of firms with different cash flow positions and investment opportunities may produce a financial synergy effect and achieve less cost of capital. Moreover, the financial synergy theory also states that when the cash flow rate of the acquirer is greater than that of the acquired firm, it means that the capital is relocated to the acquired firm and its investment opportunities tend to improve [64]

4.2 Differential Efficiency Theory

The efficiency theory of M&As states that, firms that operate below their potential or have low efficiency are likely to be acquired by more efficient firm in order to achieve the increase level of efficiency of firm and by coming together they would also have the managerial ability to improve performance. However, difficulty would arise when the acquiring firm overestimates its impact on improving the performance of the acquired firm and this may result in the acquirer paying too much for the acquired firm. Alternatively, the acquirer may not be able to improve the acquired firm's performance up to the level of the acquisition value given to it. This theory also suggest that, the synergy of M&As can only be achieved when both firms are expected to make a deal and benefited from it (Christine & Jagongo, 2018; Trautwein, 1990).

4.3 Hubris Theory

Hubris theory establishes a psychological approach to explain M&As. The theory suggests that managers may have good intentions in increasing their firm's performance but being overconfident, they overestimate their abilities to create synergies. It further states that the management of acquiring firms over rates their ability to evaluate potential acquisition targets which typically results in

erroneous decisions of overprice, overconfidence and lead to the probability of overpaying (Christine & Jagongo, 2018; Roll, 1986)

Table 3.1 Summary of the critical analysis and inconsistency in the previous literature of performance of M&As in both DE and EE.

Author/Year	Firm Type	Period/ Sample Size	Key Findings
Weinberg, 1979	Railroad transportation in USA	1967–1971/ 221	With regard to geographical configuration, horizontal mergers achieve higher gains in market share than vertical or mixed transactions. Market share reflect the underlying cost, service quality improvements, merger related cost savings, performance improvements in terminal operations and outweigh those in line haul operations.
Slovin, Sushka, & Hudson, 1991	Air transportation in USA	1965–1988/ 42	For the shareholder of acquiring and target firms there is a significant positive abnormal returns. However, abnormal returns for acquiring firms decrease and abnormal returns for target firms increase after deregulation while firms earn positive average abnormal returns for transactions with nontrivial changes in industry concentration, but after deregulation, transactions have no significant valuation effects on rival firms
Singal, 1996	Air transportation in USA	1985–1988 /42	The acquiring and target firms earn significantly positive abnormal returns in contrast to rival firms' stockholders that on average neither benefit nor lose from transactions due to contradictory effects of more efficient operations and less competition. Consolidating transactions in which both firms operate in the same geographic market are expected to induce significantly higher efficiency and market power gains than expanding transactions and abnormal stock returns are correlated with profit changes due to market anticipation.
Samitas, G, Kenourgios, & F, 2007	Water transportation in USA	2000– 2007/15	The abnormal return is significant and positive after the announcement of the M&As and remains stable especially for the tramp shipping firms that do not serve standardized routes but announcement of transactions have a direct positive impact on stock value.
Darkow, Kaup, & Schiereck, 2008	Freight transportation	1991– 2006/200	Cross-border transactions generate significantly higher returns than national ones and transactions with large volumes appear more successful than smaller ones whereas the positive abnormal returns for shareholders of acquirer firms, target firms and the combined entity appears to be found. From an acquirer's perspective focusing transactions perform better than diversifying ones.
Liao & Williams, 2008	Some US and Europe Banks	1998-2005/74	The circumstances are delicate to the nationality of acquiring banks, the markets seem to value US and Dutch bank purchases but the results are not consistent to every window measurement that made the outcome of M&As appears to be neither positive nor negative.
Chari Liao & Williams, Ouim, 2010	Public and private M&A from Thomson's data base	1986- 2006/2218	The evidence suggests that, the acquirer's returns shows a significant increase when they acquire control of EE targets while domestic M&A transactions and distribution of gains shifts in favor of acquiring firms. The greater lack of equality between DE and emerging market institutions, the higher positive acquirer's returns for DE.
Kammlott & Schiereck, 2011	Water transportation	1980– 2007/213	The result shows a negative abnormal returns for the acquirers' shareholders but shows a positive abnormal returns for the targets' shareholders. Transnational transactions exhibit significant negative abnormal returns for acquirers with regional differences while European transactions are evaluated more significant successful than those from Asia.
Oghojafor, A, Adebisi, & Abayomi, 2012	Commercial Banks in Nigeria	2001-2010/5	This evident showed that the merger and acquisition was only able to rescue the banks from collapse in 2005, however, the financial indices showed an improved performance after merger, but it did not translate into objectives of repositioning the banking sector for effective performance.
Andreou,	Freight	1980–	Positive deal value accrues mostly to targets shareholders rather than to

Louca, & Panayides, 2012	transportation in USA	2009/289	acquirers shareholders. Acquirer returns are positively influenced by friendly transactions.
Bertrand & Betschinger, 2012	Zephir & Ruslana Stock exchange data base	1999-2008/609	The result indicates that, there is a negative effects associated with acquisitions. However, the firm resources are relevance and can be leveraged in domestic deals to improve the impact of acquisitions and there is no evidence that, agency problems are the driving factor of the negative effect in long-term performance of acquisitions.
Nicholson & Salaber, 2013	Thomson's data stream (Shezhen, Shanghai and Indian Stock exchange)	2000-2010/389	when the target firm is located in a developed country, the acquirers from both nations gain more returns. Moreover, developed markets have more advanced tangible and intangible resources and consistent institutional rules to enjoy the advantages and increase the value of their shareholders.
Alexandrou, Gounopoulos, & Thomas, 2014	Water transportation	1984-2011/1266	Results shows a positive abnormal returns for both shareholders of acquirer firms and shareholder of target firms. Moreover, acquirers' shareholder gains significantly across maritime sectors and regions but are generally driven by, higher acquirer profitability, smaller acquirer size, stock financing and cross-border deals.
Cortés, García, & Agudelo, 2015	Air transportation in South America	1996-2013/28	Target firms realize significant positive abnormal returns especially in cases where transactions are considered to be strategic and the shareholders expect the integration to create substantial synergies. However, acquirers' shareholders do not realize significant abnormal changes in stock returns around the transaction announcement.
Kuriakose & Paul, 2016	Sample Bank merger deals in India	2000-2011/10	The acquirer banks profitability improved compared to target banks, again a bidder banks have shown better results in terms of profits, that is net profit after tax, earning per share, return on asset (ROA) and return on equity (ROE) in a situation of pre-merger performance.
Tao, Liu, Gao, & Xia, 2017	Listed Chinese firms	2000-2012/165	The findings show that, on average, cross-border M&As by Chinese listed firms generated a positive market reaction by producing positive abnormal returns to the shareholdings of acquiring firms
Christine & Jagongo, 2018	Commercial Banks 2010-2017/9	2010-2017/9	Operational synergy, differential efficiency, risk diversification and market share development as indicators of M&A have a positive significant influence on the financial performance of the commercial banks in Kenya. The variables explained 98.2% of the changes in financial performance of the commercial banks.

5 CORPORATE GOVERNANCE AND FIRMS PERFORMANCE.

Al-Saidi & Al-Shammari (2013) stated that, corporate governance allows for better monitoring so that the managers can make decisions in the interest of their shareholders such as financing in a project that can yielded a positive net present value and improves protection to the shareholders by reducing the opportunistic practice of the managers that can decreases firm value. Therefore, firms more likely to have a higher firm value if the corporate governance are well implimented [70]. For the firms value-maximizing shareholders are likely to favor risky capitalization strategies compared to managers, especially such strategies may enhance firm's prospects of receiving generous layouts in the event of failure [71]. According to

Siagian, Siregar, and Rahadian (2013) a set of governance practice can be implemented to ease the agency problems. Previous studies related to the corporate governance have been conducted especially in the effect on firm performance. For example in research conducted by Hoque, Islam, and Ahmed 2013; Kusmayadi, 2012; Outa and Waweru 2016) found that corporate governance had a positive effect on financial performance. During the Asian financial crisis, five East Asian countries was reported to have a positive relationship between corporate governance and firms performance [75]. Consistent with the above studies, Siagian et al. (2013) reported that corporate governance is positively associated with firm value for public firms in Indonesia.

In addition, Durnev and Kim (2005) found firms with higher governance and clearness rankings have more

valued in stock markets. Ashbaugh, Collins, and LaFond (2004) found that firms with improved governance have lesser cost of equity capital resulting in a better firm value. Furthermore, Bhagat and Bolton (2007) reported that, the empirical studies revealed on how corporate governance index with performance was strongly correlated with stock returns during 1990s. Corporate governance does not always have a positive impact on the company's performance immediately [24]. This is supported by (Aebi, Sabato, and Schmid, 2012; Halbouni, Obeid, and Garbou 2016) which stated that corporate governance practiced, have no significant effect on financial performance. Moreover, Hassan and Tamimi, (2012) reported an insignificance relationship between corporate governance and UAE Nation's bank performance.

Moreover, Buallay and Hamdan, (2017) revealed that there was a significant impact between the size of the Board of Directors, ownership and firm's performance. The study examined the relationship between corporate governance and performance of Saudi companies listed on the stock exchange in a sample of 171 listed companies for period of 2012 to 2014 using ROA to measure operational performance, ROE to measure financial performance and Tobin's Q to measures market performance. The results shows the positive significant effect of audit committee on ROA, Tobin's Q and firm performance. While the effect of internal audit on ROA was found to be positively significant, the effect of the same variable on Tobin's Q was not supported by the results of the empirical study.

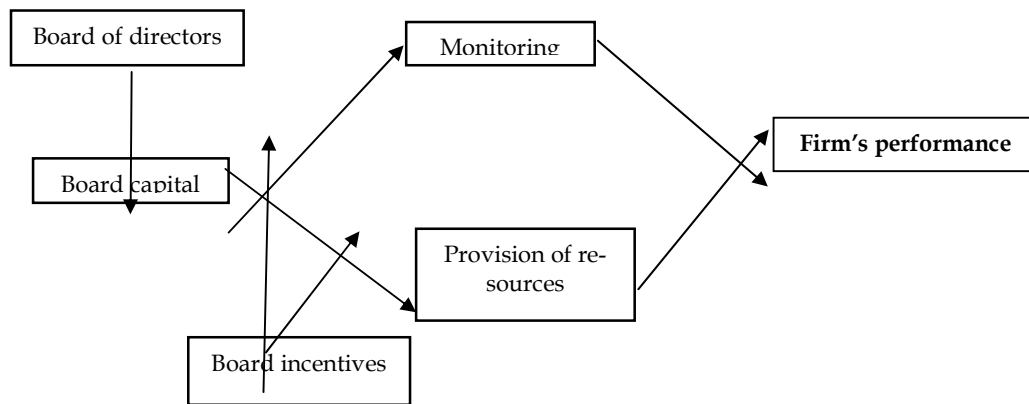

Figure 5.1 Background model of the relationship between board of directors and firm's performance.

5.1 Links between boards of directors to firm's performance

The links between boards of directors and firm performance are usually follow either one of two paths but the dominant path is that of agency theorist, who contend that the most significant activity for boards is monitoring management on behalf of shareholders while effective monitoring can improve firm performance by reducing agency costs [83]. The researchers further examined the relationship between proxies for board incentives to monitor both board dependence and firm performance and revealed that, there is no statistical support for a relationship between board incentives to monitor and firm performance (Dalton, Daily, Certo & Roengpitya 2003; Dalton, Daily, & Johnson, 1998)

The second path researchers take the study of boards and firm performance based on resource dependence theory. In this research scholars examine the relationship between the board as a provider of resources for example advice, legitimacy and counsel links to other organizations and firm performance but their primary concern in this research tradition is what they refer to as board capital

[83]. Resource dependence theorists examine how board capital leads to the provision of resources to the firm. Empirical studies in the resource dependence tradition have shown a relationship between board capital and firm performance (Boyd, 1999; Dalton, Daily, & Ellstrand, 1999; Pfeffer, 1972).

5.2 Board capital to firm performance

Many researchers in resource dependence perspective have linked board capital directly to the provision of resources and firm performance, in the hypothesis is that, board capital is positively associated with the provision of resources by the board, which in turn, is positively associated with firm performance [83]. conclusively [88] argue that board capital improves monitoring directly which also improves performance.

5.3 Monitoring to firm performance

According to agency theory, monitoring is the primary function of board incentives while agency theorists acknowledge that boards of directors varies in their incentives to monitor in order to protect shareholder interests,

as a result of that incentives are important for effective monitoring. Agency theorists suggest that when incentives are aligned with shareholders' interests, boards will be more effective to monitor management and also improves performance (Fama, 1980; Company, Jensen, & Meckling, 1976)

5.4 Provision of resources to firm performance

Although resource dependence logic suggested that board's provision of resources is related directly to firm performance [83]. Provision of resources help reduce dependency between the organization and external contingencies [91], diminish uncertainty for the firm [33], lower transaction costs and ultimately aid in the survival of the firm [92].

5.5 Board of Incentives to firm performance

The agency theorists have argued for a direct relationship between board incentives and monitoring [83]. However, behavioral scientists has regarded incentives as important factor for moderating between individual's ability and his or her performance. [93]

6 CONCLUSION

This paper is an attempt to identify the literature gaps in the study of M&A and performance of firms and the study controbuted to the literature in so many ways. In the first attempt in the literature, we comprehensively review the previous studies on M&A in both DE and EE and summarised the key findings in the relationship between M&A and performance of firms. After the searching and reviewing the literature we found that there are serious inconsistency and contradictory results that does exist in the relationship between M&A and performance. Based on the literature, we integrate the findings to develop a propositions and suggest the solution for the inconsistency and contradictory results on the relationship between M&A and firm's performance.

Secondly, based on the literature, this study found that, one of the most important corporate governance mechanism i.e board of directors are both internally and externally assocaited with higher firms performance, the study also suggest that corporate governance mechanisms can be introduce as a moderator in the relationship between M&A and firms performance to find a soluton in the literature and findings in both DE and EE. Moreover, the study found some advanced theories to justify the impact of M&A and explained that M&A can simply generate synergy between acquirer and target and also increase firm's performance.

At this juncture, researchers believe that firm performance may be influenced by well-structured and functional board's directors to achieve a desired firm's performance with their role in monitoring the managerial operations of

a firm [94]. However, the empirical relationships between M&As and firms performance are not without controversy but the activities of M&As are increasingly undertaken by a number of firms, not only in DE but also in EE. However, this paper contributes by investigating the moderating effect of corporate governance on the relationship between merger and acquisition and firm's performance (Baron & Kenny, 1986; Rezaul Kabir, 2017; Hair et al., 2017)

6.1 Suggestion for future research

This study evaluated the theoretical and empirical literature related to M&As and firm's performance and the areas of gaps for future research. Both theoretical and methodological have been able to be established. Furthermore, it highlights the importance of more quantitative methods for in-depth understanding of the relationship between the three variables under review. Therefore, future researchers may find them useful for empirical investigation.

REFERENCES

- [1] G. Alexandrou, D. Gounopoulos, and H. M. Thomas, "Mergers and acquisitions in shipping," *Transp. Res. Part E Logist. Transp. Rev.*, vol. 61, pp. 212–234, 2014.
- [2] B. Aybar and A. Ficici, "Cross-border an analysis acquisitions aCross-border an analysis acquisitions and firm value: Multinationals of emerging-marketnd firm value," *J. Int. Bus. Stud.*, vol. 40, no. 8, pp. 1317–1338, 2009.
- [3] O. Bertrand and M. A. Betschinger, "Performance of domestic and cross-border acquisitions: Empirical evidence from Russian acquirers," *J. Comp. Econ.*, vol. 40, no. 3, pp. 413–437, 2012.
- [4] L. M. Cortés, J. J. García, and D. Agudelo, "Effects of Mergers and Acquisitions on Shareholder Wealth: Event Study for Latin American Airlines," *Lat. Am. Bus. Rev.*, vol. 16, no. 3, pp. 205–226, 2015.
- [5] O. Christine and A. Jagongo, "Mergers and acquisitions on financial performance among selected commercial banks, Kenya," *Int. Acad. J. Econ. Financ.*, vol. 3, no. 1, pp. 1–23, 2018.
- [6] A. Liao and J. Williams, "Do win-win outcomes exist? A study of cross-border M&A transactions in emerging markets," *J. Econ. Lit.*, vol. 50, no. 2, pp. 274–296, 2008.
- [7] R. R. Nicholson and J. Salaber, "The motives and performance of cross-border acquirers from emerging economies: Comparison between Chinese and Indian firms," *Int. Bus. Rev.*, vol. 22, no. 6, pp. 963–980, 2013.
- [8] M. B. Slovin, M. E. Sushka, and C. D. Hudson, "Deregulation, contestability, and airline acquisitions," *J. financ. econ.*, vol. 30, no. 2, pp. 231–251, 1991.

- [9] V. Singal, "Airline mergers and competition: An integration of stock and product Price effects," *J. Bus.*, vol. 69, no. 2, pp. 233–268, 1996.
- [10] F. Tao, X. Liu, L. Gao, and E. Xia, "Do cross-border mergers and acquisitions increase short-term market performance? The case of Chinese firms," *Int. Bus. Rev.*, vol. 26, no. 1, pp. 189–202, 2017.
- [11] R. C. L. and D. H. Weinberg, "Alternatives for restructuring the railroads: End-to-end or parallel mergers?," *Railr. Revital. Regul. Reform*, vol. XVII, no. July, pp. 371–388, 1985.
- [12] S. Lebedev, M. W. Peng, E. Xie, and C. E. Stevens, "Mergers and acquisitions in and out of emerging economies," *J. World Bus.*, vol. 50, no. 4, pp. 651–662, 2015.
- [13] M. Bastomi, U. Salim, and S. Aisjah, "The role of corporate governance and risk management on banking financial performance in Indonesia," *J. Keuang. dan Perbank.*, vol. 21, no. 4, pp. 589–599, 2017.
- [14] E. S. Sumon Kumar Bhaumik, "Does ownership concentration improve M & A outcomes in emerging markets? Evidence from India," *J. Corp. Financ.*, vol. 18, no. 4, pp. 717–726, 2012.
- [15] R. M. Baron and D. A. Kenny, "The moderator-mediator variable distinction in social psychological research: Conceptual, strategic, and statistical considerations," *J. Pers. Soc. Psychol.*, vol. 51, no. 6, pp. 1173–1182, 1986.
- [16] H. M. T. Rezaul Kabir, "Does corporate governance shape the relationship between corporate social responsibility and financial performance?," *Pacific Account. Rev.*, vol. 29, no. 2, pp. 227–258, 2017.
- [17] J. F. Hair, G. T. Hult, and M. C. M. Ringle, *A primer on partial least squares structural equation modeling*, Second Edi. Los Angeles: SAGE Publications, Inc., 2017.
- [18] [29] S. A. O. S.A. Aduloju, A.L. Awoponle, "Recapitalization, mergers, and acquisitions of the Nigerian insurance industry," *J. Risk Financ.*, vol. 9, no. 5, pp. 449–466, 2008.
- [19] R. H. McGuckin, "On productivity and plant ownership change: New evidence from the longitudinal research database," *RAND J. Econ.*, vol. 26, no. 2, pp. 257–276, 1995.
- [20] B. E. H. A. N. Kim and V. Singal, "Mergers and Market Power: Evidence from the airline industry," *Am. Econ. Assoc.*, vol. 83, no. 3, pp. 549–569, 1993.
- [21] T. C. and M. J. Piskorski, "Power imbalance, mutual dependence, and constraint absorption: A closer look at resource dependence theory," *Sage Publ. Inc.*, vol. 50, no. 2, pp. 167–199, 2005.
- [22] J. Pfeffer, "Size and composition of corporate boards of directors: The organization and its environment," *Sage Publ. Inc.*, vol. 17, no. 2, pp. 218–228, 1972.
- [23] O. Williamson, *The economic institutions of capitalism*, First. New York: The Free Press, 1985.
- [24] David R. King and R. J. S. and I. Kesner, "Intensive firms performance implications of firm resource interactions in the acquisition of R & D-intensive firms," *INFORMS*, vol. 19, no. 2, pp. 327–340, 2008.
- [25] J. P. Antony and S. Bhattacharyya, "Measuring organizational performance and organizational excellence of SMEs – Part 1: A conceptual framework," *Meas. Bus. Excell.*, vol. 14, no. 2, pp. 3–11, 2010.
- [26] J. Hales, *Accounting and financial analysis in the hospitality industry*. New York: Butterworth-Heinemann, 2005.
- [27] A. AbdulRasheed, I. S. Babaita, and M. A. Yinusa, "Fraud and its implication for bank performance in Nigeria," *Int. J. Asian Soc. Sci.*, vol. 2, no. 4, pp. 382–387, 2012.
- [28] H. Fauzi, "The Performance Implications of Fit among Environment, Strategy, Structure, Control System and Social Performance," *Issues Soc. Environ. Account.*, vol. 3, no. 2, pp. 117–142, 2010.
- [29] R. Simons, *Performance Measurement and Control Systems for Implementing Strategy Text and Cases*, Fourth. New Jersey, USA: Pearson education limited, 2013.
- [30] Z. Hoque, "A contingency model of the association between strategy, environmental uncertainty and performance measurement: Impact on organizational performance," *Int. Bus. Rev.*, vol. 13, no. 4, pp. 485–502, 2004.
- [31] J. F. Henri, "Performance measurement and organizational effectiveness: Bridging the gap," *Manag. Financ.*, vol. 30, no. 6, pp. 93–123, 2004.
- [32] A. Neely, *Business Performance Measurement; Unifying theories and integrating practice*, Second. New York: Cambridge University Press, 2007.
- [33] E. W. Gitau and N. G. Samson, "Effect of financial fraud on the performance of commercial banks: A case study tier 1 banks in Nakuru town, Kenya," *Int. J. Econ. Commer. Manag.*, vol. IV, no. 12, pp. 142–157, 2016.
- [34] F. S. Mishkin, "Housing and the Monetary Transmission Mechanism," *J. Manage.*, vol. 4, no. 2, pp. 655–670, 2007.
- [35] [46] C. Ittner and D. Larcker, "Property development and the unresolved housing issue in northern Nigeria," vol. 1, 2003.
- [36] Z. Chibueze, O. Maxwell, and M. Osondu, "Electronic banking and bank performance In

- Nigeria," *West African J. Ind. Acad. Res.*, vol. 6, no. 1, pp. 171–187, 2013.
- [37] Z. Abaenewe, O. Ogbulu, and M. Ndugbu, "Electronic banking and bank performance in Nigeria," *West African J. Ind.*, vol. 6, no. 1, pp. 171–187, 2013.
- [38] N. Bontis, W. C. C. Keow, and S. Richardson, "Intellectual capital and business performance in Malaysian industries," *J. Intellect. Cap.*, vol. 1, no. 1, pp. 85–100, 2000.
- [39] P. M. Hamann, F. Schiemann, L. Bellora, and T. W. Guenther, "Exploring the dimensions of organizational performance: A construct validity study," *Organ. Res. Methods*, vol. 16, no. 1, pp. 67–87, 2013.
- [40] G. Murphy, J. Trailer, and R. Hill, "Measuring Research Performance in Entrepreneurship," *J. Bus. Res.*, vol. 36, no. 1, pp. 15–23, 1996.
- [41] Suvita Jha and X. Hui, "A comparison of financial performance of commercial banks: A case study of Nepal," *African J. Bus. Manag.*, vol. 6, no. 25, pp. 7601–7611, 2012.
- [42] J. K. Kinyua, R. Gakure, M. Gekara, and G. Orwa, "Effect of Internal Control Environment on the Financial Performance of Companies Quoted in the Nairobi Securities Exchange," *Int. J. Innov. Financ. Econ. Res.*, vol. 3, no. 4, pp. 29–48, 2015.
- [43] J. G. Combs, T. R. Crook, and C. L. Shook, "The dimensionality of organizational performance and its implications for strategic management research," in *Research methodology in strategy and management*, Volume 2., D. J. Ketchen and D. D. Berch, Eds. Netherland: Elsevier Lt, 2005.
- [44] P. P. O. and L. L. T. Anusha Chari, "The value of control in emerging markets," *Soc. Financ. Stud.*, vol. 23, no. 4, pp. 1741–1770, 2010.
- [45] [56] J. Chi, Q. Sun, and M. Young, "Performance and characteristics of acquiring firms in the Chinese stock markets," 2011.
- [46] S. R. Gubbi, P. S. Aulakh, S. Ray, and M. S. and R. Chittoor, "Do international acquisitions by emerging-economy firms create shareholder value? The case of Indian firms," *J. Int. Bus. Stud.*, vol. 41, no. 3, pp. 397–418, 2010.
- [47] [58] S. Bhagat, S. Malhotra, and P. C. Zhu, "Emerging country cross-border acquisitions: Characteristics, acquirer returns and cross-sectional determinants," *Emerg. Mark. Rev.*, vol. 12, no. 3, pp. 250–271, 2011.
- [48] Samitas, A. G. Kenourgios, and D. F., "Impact of mergers and acquisitions on stock returns of tramp shipping firms," *Int. J. Financ. Serv. Manag.*, vol. 2, no. 4, pp. 327–343, 2007.
- [49] I. L. Darkow, C. Kaup, and D. Schiereck, "Determinants of merger & acquisition success in global logistics," *Int. J. Logist. Res. Appl.*, vol. 11, no. 5, pp. 333–345, 2008.
- [50] C. Kammlott and D. Schiereck, "Ship of fools or passage to profit? – The value implications of M&A in international shipping industry," *Int. J. Ecol.*, vol. 2, no. June, pp. 56–69, 2011.
- [51] P. C. Andreou, C. Louca, and P. M. Panayides, "Valuation effects of mergers and acquisitions in freight transportation," *Transp. Res. Part E*, vol. 48, no. 6, pp. 1221–1234, 2012.
- [52] H. Singh and M. Zollo, "Post-acquisition strategies, integration capability, and the economic performance of corporate acquisitions," *J. Bus. Res.*, vol. 6, no. 2, pp. 1–42, 1999.
- [53] Z. Fluck and A. W. Lynch, "Why do firms merge and then divest? A theory of financial synergy," *J. Bus.*, vol. 72, no. 3, pp. 319–346, 1999.
- [54] F. Trautwein, "Merger motives and merger prescriptions," *Strateg. Manag. J.*, vol. 11, no. 4, pp. 283–295, 1990.
- [55] R. Roll, "The hubris hypothesis of corporate takeovers," *J. Bus.*, vol. 59, no. 2, pp. 197–216, 1986.
- [56] Oghojafor, B. E. A, Adebisi, and S. Abayomi, "Evaluating mergers and acquisition as strategic interventions in the Nigerian banking Sector: The good, bad and the ugly," *Int. Bus. Res.*, vol. 5, no. 5, pp. 147–158, 2012.
- [57] [68] S. Kuriakose and J. Paul, "Strategic and financial similarities of bank mergers," *Rev. Int. Bus. Strateg.*, vol. 26, no. 1, pp. 50–68, 2016.
- [58] M. Al-Saidi and B. Al-Shammari, "Board composition and bank performance in Kuwait: an empirical study," *Manag. Audit. J.*, vol. 9, no. 8, pp. 40–62, 2013.
- [59] F. Siagian, S. V. Siregar, and Y. Rahadian, "Corporate governance, reporting quality, and firm value: Evidence from Indonesia," *J. Account. Emerg. Econ.*, vol. 3, no. 1, pp. 4–20, 2013.
- [60] D. Anginer, A. Demircuc-Kunt, H. Huizinga, and K. Ma, "Corporate governance and bank capitalization strategies," *J. Financ. Intermediation*, vol. 26, pp. 1–27, 2016.
- [61] M. Z. Hoque, R. . Islam, and H. Ahmed, "Corporate governance and bank performance: The case of Bangladesh," *J. Econ. Lit.*, pp. 1–37, 2013.
- [62] D. Kusmayadi, "Determinasi audit internal dalam mewujudkan good corporate governance serta implikasinya pada kinerja bank," *J. Keuang. dan Perbank.*, vol. 16, no. 1, pp. 152–187, 2012.
- [63] E. R. Outa and N. M. Waweru, "Corporate governance guidelines compliance and firm financial performance," *Manag. Audit. J.*, vol. 31, no. 8/9, pp. 891–914, 2016.
- [64] T. Mitton, "A cross-firm analysis of the impact of

- corporate governance on the East Asian financial crisis," *J. financ. econ.*, vol. 64, no. 2, pp. 215–241, 2002.
- [65] A. Durnev and E. H. Kim, "To steal or not to steal: Firm attributes, legal environment, and valuation," *J. Finance*, vol. 60, no. 3, pp. 1461–1493, 2005.
- [66] H. Ashbaugh, D. W. Collins, and R. LaFond, "Corporate Governance and the Cost of Equity Capital," *Emory Univ. Iowa*, vol. 6, no. October, pp. 1–49, 2004.
- [67] S. Bhagat and B. Bolton, "Corporate Governance And Firm Performance," *Cornell Univ. Dartmouth Coll.*, no. June, pp. 1–58, 2007.
- [68] V. Aebi, G. Sabato, and M. Schmid, "Risk management, corporate governance, and bank performance in the financial crisis," *J. Bank. Financ.*, vol. 36, no. 12, pp. 3213–3226, 2012.
- [69] S. S. Halbouni, N. Obeid, and A. Garbou, "Corporate Governance and Information Technology in Fraud Prevention and Detection: Evidence from the UAE," *Manag. Audit. J.*, vol. 31, no. 6/7, pp. 589–628, 2016.
- [70] H. A. Hassan and A. Tamimi, "The effects of corporate governance on performance and financial distress: The experience of UAE national banks," *J. Financ. Regul. Compliance*, vol. 20, no. 2, pp. 169–181, 2012.
- [71] A. Buallay and A. Hamdan, "Corporate governance and firm Performance: Evidence from Saudi Arabia," *Int. J. Econ. Financ. Issues*, vol. 11, no. 1, pp. 78–98, 2017.
- [72] A. J. Hillman and D. Thomas, "Boards of directors and firm performance: Integrating agency and resource dependence perspectives," *Acad. Manag.*, vol. 28, no. 3, pp. 383–396, 2003.
- [73] D. R. Dalton, C. M. Daily, S. T. Certo, R. Roengpitya, and C. M. Daily, "Meta-analyses of financial performance and equity: Fusion or confusion?," *Acad. Manag. J.*, vol. 46, no. 1, pp. 13–26, 2003.
- [74] D. R. Dalton, C. M. Daily, and A. E. E. and J. L. Johnson, "Meta-analytic reviews of board composition, leadership structure, and financial performance," *Strateg. Manag. J.*, vol. 19, no. 3, pp. 269–290, 1998.
- [75] B. Boyd, "Corporate linkages and organizational environment: A test of the resource dependence model," *Strateg. Manag. J.*, vol. 11, no. 6, pp. 419–430, 1990.
- [76] J. L. J. and A. E. E. Dan R. Dalton, Catherine M. Daily, "Number of directors and financial performance: A meta-analysis," *Acad. Manag. J.*, vol. 42, no. 6, pp. 674–686, 1999.
- [77] M. N. Zald, "The power and functions of boards of directors: A theoretical Synthesis," *Am. J. Sociol.*, vol. 75, no. 1, pp. 97–111, 1969.
- [78] E. F. Fama, "Agency problems and the theory of the firm," *J. Polit. Econ.*, vol. 88, no. 2, pp. 288–307, 1980.
- [79] P. Company, C. Jensen, and H. Meckling, "Theory of the firm: Managerial behavior, agency costs and ownership structure," *J. financ. econ.*, vol. 3, no. 4, pp. 305–360, 1976.
- [80] G. R. Salancik, H. J. Reitz, J. S. Bowman, J. Pfeffer, and G. R. S. The, "External control of organizations: A resource dependence perspective," *Acad. Manag. Rev.*, vol. 4, no. 2, pp. 309–310, 1979.
- [81] R. J. H. and D. J. T. Jitendra V. Singh, "Organizational change and organizational mortality," *Sage Publ. Inc*, vol. 31, no. 4, pp. 587–611, 1986.
- [82] J. E. Hunter and R. F. Hunter, "Validity and utility of alternative predictors of job performance," *Am. Psychol. Assoc. Inc*, vol. 96, no. 1, pp. 72–98, 1984.
- [83] P. C. P. V. John A. Pearce, "Board of director efficacy and firm performance variability," *Long Range Plann.*, vol. 1, no. 16, pp. 1–16, 2017.

The Study of Impact Factors in Knowledge Management on Business Performance in Chinese Enterprises

Zou Danting

International Business School, Universiti Teknologi Malaysia, 54100, Kuala Lumpur Malaysia

* dzou2@live.utm.my

Abstract— This study develops a research proposal to exam the relationship between knowledge management with business performance in small size enterprises in China. The author also tries to figure out the critical impact factors that affect the business performance in these enterprises during implementation the knowledge management process. In the relevant fields, the researcher figures out the important variables including: knowledge management, business performance, strategy, organizational culture, organizational processes, leadership, technology, corporate politics, and educational level.

Keyword—business performance; impact factor; knowledge management; small size enterprise.

1 INTRODUCTION

The concept of knowledge management was established in the early 90s in last century. Most of the large enterprises have enough resources to develop and implement their enough knowledge management system and utilize into their business developing process (Heisig 2003). Knowledge management efforts typically focus on organizational objectives such as improved performance, competitive advantage, innovation, the sharing of lessons learned, integration and continuous improvement of the organization. These efforts overlap with organizational learning and may be distinguished from that by a greater focus on the management of knowledge as a strategic asset and on encouraging the sharing of knowledge (Gold and Arvind Malhotra 2001).

Nowadays, the technology has been developed faster than ever before, change is the only certain factor that can be confirmed today. Due to the rapid change of the market and customer needs, the enterprises must be more competitive than before, that means the enterprise must improve themselves in all aspects, then, it can only catch up with the trends. To do that, the enterprises need to be faster to create, share and use the new knowledge, since in today's new economic circumstance, knowledge is the main factor to push the economic growths. It is estimate that 80 percent of the economic growth depends on the new knowledge in this century (McDermott 1999).

1.1 Problem Statement

The enterprises in China today must face a new era which is the Era of knowledge management. With the fast development of the economic since the 2000, the economic circumstance, economic policies, rules and regulations, and the concept of business management have been different from the old days, the manufactural industry need innovation, the marketing need innovation, and the management methods need innovation as well. Knowledge management is the core content of the business management and innovation in the recent year in all the industries in China. There are good opportunities for the enterprises in China to develop their own knowledge management system and implement that into their business development process

due to the advantages of using the internet and information technology (Lee and Choi 2003).

However, according to the statistic, 99% of the enterprises in China belongs to the small size enterprises, its number already over 70 million by the end of 2016. In this context, it is necessary to analyse the circumstances within these enterprises in China, whether there are issues that will affect the implementation of knowledge management and business performance. Firstly, there is limited resources to establish and carry out the knowledge management system in these small size enterprises in China.

Furthermore, the culture of knowledge management has not been adopted by most of the small size enterprises in China. In most of the small size business in China, most of the employees don't obtain higher education. Therefore, it is difficult to raise the awareness of the importance on knowledge management concept into the workers, and most of them don't even believe the values of implement the system. It will take quite a long time with great effort to foster this knowledge management concept into the culture of these small size enterprises (David and Fahey 2000).

Hence, most of the employees don't understand how to implement the knowledge management system, as it was mentioned above, the educational level among most of employees in the small size business in China is considered as low. The consequence is the small size enterprises in China spend lots of money and resources to build the knowledge management system, however, due to the above issues mentioned above, the system has not been operated and implemented into real practice. It made these small size enterprises waste a lot of money and lose the confidence in knowledge management (Bhatt 2001).

1.2 Research Gap

The previous study and research already stated the importance of the knowledge management in the business development process, however, according to the literatures, most of the enterprises that develop and implement the knowledge management system in the business development are belong to the larger companies which have enough resources. This is lack of study in the field of knowledge management in the small size organizations in

the developing countries, especially in the emerging market like China. Therefore, this study will figure out whether the knowledge management will help most of these small size companies in China with their sustainable business development. Hence, this study will try to identify the main factors that impact the implement of the knowledge management in these small size companies in China.

1.3 Significance of Research

The findings of this research will help the small size enterprises in China to confirm that whether the implementation of knowledge management will help them with their business development, and it will also help them enterprises in China to identify the factors that prevent the implementation of the knowledge management in their organization. Therefore, the findings of the study can help the management level in these Chinese enterprises to decide whether they should use their limited resource in developing a knowledge management system into their own organization and help these managers to predict the issues that will happened during the implementation of the knowledge management system in their business.

1.4 Objective of the Research

The main objective of this research is to find out whether the knowledge management will help the business performance in the small size enterprises in China. And the sub-objective of this study is to figure out the factors that prevent the knowledge management implementation in these small size enterprises in China.

1.5 Research Question

There are two research questions that conducted base on the objectives above.

Research Question 1: What is the relationship in between knowledge management and business performance in small size enterprises in China?

Research Question 2: What are the factors that impact the knowledge management and business performance in small size enterprises in China?

1.6 Operational Definition of Concepts

Operational definition of concepts explains the meanings of certain words or phrases that using in this research proposal.

Small size enterprises: The business has less than 100 employees in China;

Higher education: Formal learning after completion of secondary school in colleges or universities including vocational schools.

1.7 Scope of the Study

This study is conducted to identify the factors that affect the correlation between knowledge management and business performance in the small size enterprises in China. Besides that, the study also focuses on whether there is a significant relationship between knowledge management and business performance in the small size enterprises in China. The study will adopt a quantitative approach, all the data will be collected through the survey question-

naire, the questionnaire will send to 1000 small enterprises in China by email.

1.8 Type of Research

The research proposal studies the issues that faced by the small enterprises in China will adopt the quantitative research method with questionnaire as the research instrument. By using quantitative research method, with the questionnaire answered by the study population in China, the result will be able to answer the research question and hypothesis.

2 LITERATURE REVIEW

2.1 Theoretical Background

This research paper is based on the theory of planned behavior (TPB). TPB is a theory that links human's beliefs and behavior. The concept was proposed by Icek Ajzen to improve on the predictive power of the theory of reasoned action by including perceived behavioral control. It has been applied to studies of the relations among beliefs, attitudes, behavioral intentions, and behaviors in various fields. The theory states that attitude toward behavior, subjective norms, and perceived behavioral control, together shape an individual's behavioral intentions and behaviors (Davenport, De Long, and Beers 1998).

2.2 Knowledge Management in Enterprises

Knowledge includes experiences, values, professional opinions, and various aspects. Usually, it has been categorized as tacit knowledge and explicit knowledge. Explicit knowledge means the knowledge that can be expressed by words, figures, or tables; and it is able to communicate and code. On the other hands, tacit knowledge means the knowledge that can't expressed directly, but need a long time to understand, like personal skills and experiences (Tuomi 1999).

Knowledge management is a new way of management idea, different scholars and researchers have their own opinion towards knowledge management. Although this concept only started from early 90s in last century, due to the rapid development of technology, there is a need of knowledge management in sustainable business development. Today, knowledge management in the concept of business development means manage the knowledge into a systemic way and coordinate the business management during business development process (Swan et al. 1999).

There are totally four parts in knowledge management namely: knowledge creating, knowledge sharing, knowledge using, and knowledge managing. These knowledge is usually from the employees, customers, competitors, and publics; then it will be divide into useful and irrelevant information, only the useful one will be transfer into knowledge; next step will be knowledge innovation, including employees, customers, and company itself; last, these knowledges will be shared and updated in the business processes (Darroch and McNaughton 2002).

2.3 Business Performance Factors

Business performance usually refer to the capability of sustainable business development. According to the previ-

ous research, it has been proven that human resources management, marketing strategies, customer relationships, customer satisfactions have the relationships with business performance, besides that, the official websites and organizational culture also have impact towards the business performance. On the other hands, it can be measured the business performance in the following 5 factors: profitability in the industry, level of business development, reputation in the industry, branding value in the industry, and its knowledge management capability (Darroch 2005).

2.4 Knowledge Management & Business Performance

According to the previous study, it is stated that knowledge management capability the only reason that enterprises have the capability of sustainable development and to be competitive in the industry. That is because some elements like the plants, facilities and objectives can be imitated. However, the knowledges within the enterprises can not be imitated. Therefore, to be competitive and dominated in the industry, investing in knowledge management and establish own knowledge management system within the enterprise is the most effective way (Alavi and Leidner 1999).

It has been proven that with the good capability of knowledge management, the enterprises can have better business performance. For example, innovation of a new product or service, it will start from the customers knowledge management, from the useful information that gather from the customers, with the knowledge within the enterprise, the company is able to transfer these knowledge into new products or service to fulfil the needs of customers. In this case, customers provide tacit knowledge and enterprise provide explicit knowledge, and with the information and knowledge from both side, a new knowledge is created and transferred into new products and services to fulfil the market needs and consumer desires. This kind of products and services could help the enterprise to obtain a group of loyal customers, which will contribute the sustainable business performance for the enterprises. On the other hand, without good knowledge management system and implementation in the enterprises, the organization will not be able to identify the market need or customer desires, then the new developed products or services may not have satisfied the customers, which will result a sequence of bad influences to the enterprises (Earl 2001).

2.5 Factors Affect the Implementing Knowledge Management

According to the previous study and literature review, there are several factors that will impact relationship between the knowledge management and business performance of small size enterprises during the process of implementing knowledge management (Yew Wong 2005):

Strategy: it is essential to make sure that the knowledge management strategy coped with the organizational strategy. Therefore, when implement the knowledge management, it will enhance the business performance (Quintas, Lefere, and Jones 1997).

Organizational Culture: to adopt a habit of knowledge management into the enterprise is as important as the knowledge management system itself. Since, it is always

the employees who create, share, use and manage the knowledge within the knowledge management system. Without a good habit of utilizing the knowledge management system among the enterprise as a culture, the knowledge management system can't contribute to the business performance at all (Varun Grover 2001).

Organizational Processes: the knowledge management system need to cope with the organizational processes, then, it won't be mess up during the implementation process. So, it is important to have a clear picture with fully understanding of the organizational processes when design the knowledge management system in the first place.

Leadership: leadership is the key factors in all the operational level, knowledge management implementation also requires strong leadership in all the management level within the organizational to ensure the system is utilized in the right way with the right person under the right position.

Technology: the knowledge management system usually required IT technology to support, therefore, a technology team or department with the newest technology is essential all the time within the enterprises.

Corporate Politics: The organizational support and endorsement in the policy level is essential for the knowledge management system to be implement well during the business development process. By doing so, the employees will be encouraged to utilize the system in the daily business operation.

Educational level: this is one of the most important factors that exist in most of the small size enterprises in China. Most of the employees don't have higher education. It will be difficult for them to understand and operate the knowledge management system.

3 RESEARCH METHODOLOGY

3.1 Research Design

This research is a quantitative research with survey questionnaire that was approached for the data collection purpose; the study population are the small size enterprises in China and the questionnaires were send to them randomly; after the data collection completed with the responded questionnaires, several analysis such as descriptive, correlation, regression and factor analysis will being taken place in order to investigate the relationship between the factors and the performance of small size enterprises in China.

This research is aimed to study the critical factors that impact the business performances of small size enterprises in China. The critical factors include: strategy, organizational culture, organizational processes, leadership, technology, corporate politics, and educational level of the employees.

3.2 Sampling Design

The research will be carried out in Mainland China. All the small size enterprises in China will be involved in this research. Therefore, the study population in this study consists of over 70 million small size enterprises in China.

According to the textbook, consider that confidence level as 95% with Margin of error, the population size of the study population (Small size enterprises in China) is more than 1 million, therefore, the sample size will be 385.

The questionnaires will be send to the target population randomly, the selected sampling technique for this study will be convenience random sampling.

3.3 Research Instrument Design

The literature review will develop the research instruments. By utilizing the quantitative research method, questionnaire as a research instrument will be used to figure out the factors that affect the business performances of small size enterprises in China. The questionnaire will be written in both English and Chinese. Pilot test with validity and reliability will be conducting to ensure the questions in the questionnaires are relevant to the research.

3.4 Data Collection

After consulting with the research supervisor and pilot test, the revised survey questionnaire will be send to 1925 of the target population randomly in China, since the Estimated response rate is 20%, the duration of the data collection was designed as 3 months.

4 CONCLUSIONS

This study is to develop a research proposal to exam the relationship between knowledge management with business performance in small size enterprises in China, and to figure out the critical impact factors that affect the business performance in these enterprises during implementation the knowledge management process. By reviewing the literatures in the relevant fields, the researcher figures out the important variables including: knowledge management, business performance, strategy, organizational culture, organizational processes, leadership, technology, corporate politics, and educational level of the employees. This study provides a clear understanding on how these impact factors affect the business performance during the knowledge management implementation process. The result of the study will benefit the researcher to help the enterprises in China to develop an effective knowledge management system for their own organizations.

REFERENCES

- [1] Alavi, Maryam, and Dorothy E Leidner. 1999. "Knowledge management systems: issues, challenges, and benefits." *Communications of the AIS* 1 (2es):1.
- [2] Bhatt, Ganesh D. 2001. "Knowledge management in organizations: examining the interaction between technologies, techniques, and people." *Journal of knowledge management* 5 (1):68-75.
- [3] Darroch, Jenny. 2005. "Knowledge management, innovation and firm performance." *Journal of knowledge management* 9 (3):101-115.
- [4] Darroch, Jenny, and Rod McNaughton. 2002. "Examining the link between knowledge management practices and types of innovation." *Journal of intellectual capital* 3 (3):210-222.
- [5] Davenport, Thomas H, David W De Long, and Michael C Beers. 1998. "Successful knowledge management projects." *Sloan management review* 39 (2):43.
- [6] David, W, and Liam Fahey. 2000. "Diagnosing cultural barriers to knowledge management." *The Academy of management executive* 14 (4):113-127.
- [7] Earl, Michael. 2001. "Knowledge management strategies: Toward a taxonomy." *Journal of management information systems* 18 (1):215-233.
- [8] Gold, Andrew H, and Albert H Segars Arvind Malhotra. 2001. "Knowledge management: An organizational capabilities perspective." *Journal of management information systems* 18 (1):185-214.
- [9] Heisig, Peter. 2003. "Business process oriented knowledge management." In *Knowledge management*, 15-44. Springer.
- [10] Lee, Heeseok, and Byounggu Choi. 2003. "Knowledge management enablers, processes, and organizational performance: An integrative view and empirical examination." *Journal of management information systems* 20 (1):179-228.
- [11] McDermott, Richard. 1999. "Why information technology inspired but cannot deliver knowledge management." *California management review* 41 (4):103-117.
- [12] Quintas, Paul, Paul Lefere, and Geoff Jones. 1997. "Knowledge management: a strategic agenda." *Long range planning* 30 (3):322385-391.
- [13] Swan, Jacky, Sue Newell, Harry Scarbrough, and Donald Hislop. 1999. "Knowledge management and innovation: networks and networking." *Journal of Knowledge management* 3 (4):262-275.
- [14] Tuomi, Ilkka. 1999. "Data is more than knowledge: Implications of the reversed knowledge hierarchy for knowledge management and organizational memory." *Systems Sciences*, 1999. HICSS-32. Proceedings of the 32nd Annual Hawaii International Conference on.
- [15] Varun Grover, Thomas H Davenport. 2001. "General perspectives on knowledge management: Fostering a research agenda." *Journal of management information systems* 18 (1):5-21.
- [16] Yew Wong, Kuan. 2005. "Critical success factors for implementing knowledge management in small and medium enterprises." *Industrial Management & Data Systems* 105 (3):261-279.

Examine the Effect of Agricultural, Manufactured and Services (Value Added) on GDP Per Capita

Simeon Olubukola Adeogun¹ and Musibau Akintunde Ajagbe^{2*}

¹Multipro Consumer Products Limited, Lagos, Nigeria.

²Faculty of Management Sciences, Durban University of Technology, RSA

* ajagbetun@gmail.com

Abstract—The study aimed at examining the Effect of Agricultural, Manufactured and Services (Value Added) on GDP Per Capita. In this study, the authors analysed secondary data from archives of government and international development agencies. The Solow growth model was modified to incorporate the non-oil export product diversification, while using an autoregressive distributed lagged model and granger causality test. Results from all the co-integration tests confirmed evidence for a long-run co-integration since the computed F-Statistics for Wald test value exceeds both the upper bounds and lower bounds critical values for all level of significance in Nigeria. The results of the long-run and short-run ARDL model on the impact of agriculture, manufacture and services value added on output performance reveal that the effect of services value added on GDP per capita is positive and insignificant, while the impact of manufacturing value added is negative and significant. Hence, there is need for further consolidation of Nigeria's traditional sectors with greater emphasis on the production of higher-value-added products, which entails investment in modernizing the technology base for these sectors. Thus, future studies should identify further economic performance variables with respect to specific countries and consider how these variables play their roles for better economic performance.

Keyword — Export Diversification, Economic Growth, Gross Domestic Product, Per Capita Income

1. INTRODUCTION

The background of this research consists of a brief review of literature on export diversification, decomposition of export diversification and the examination of the decomposed variables of export diversification such as the following; agricultural value added exports, manufacturing value added exports and services value added exports. In addition, the impact of the decomposed variables on gross domestic product per capita in area of economic performance was also examined. In the next section of this study is the methodology, followed by the research analysis, discussion of results, and conclusion of the study. Thus, the main objective of this study is to examine the effect of agricultural, manufactured and services (value added) on GDP per capita in Nigeria.

2 REVIEW OF LITERATURE

2.1 Export Diversification

Export diversification has been variously defined as the change in the composition of a country's existing export product mix or export destination (Yonghui, 2003; Xu and Lu, 2007), or as the spread of production over many sectors (Berthelemy and Chauvin, 2000). However, as part of an export led growth strategy, export diversification is conceived as the progression from traditional to non-traditional exports (Agasha, 2009; Spence et al., 2012). Thus, by providing a broader base of exports, diversification can lower instability in export earnings, expand export revenues, upgrade value-added, and enhance growth

through various areas. These include: improved technological capabilities (Ajagbe and Ismail, 2014; Ajagbe et al., 2012) via broad scientific and technical training as well as learning by doing, facilitation of forward and backward linkages within output of some activities which then become input of some other activities; increased sophistication of markets, scale economies and externalities, and substitution of commodities with positive price trends for those with reducing trends in price (Barthelemy and Chauvin, 2000; Adeogun and Ajagbe, 2018). Given, the scope of this current study, the next section depicts the trend analysis of Non-oil export product diversification in Nigeria.

2.2 Decomposition of Export Diversification

Ayanwale (2007) categorized the Nigerian local sector into the oil and non-oil sector. However, this study focuses exclusively on the non-oil sector of the economy; that is the whole of the economic activities less oil and gas sub-sector. It covers agriculture, industry and the services sub-sector, including transport, communication, distributive trade, financial services, insurance, government, etc. in a very broad terminology. Each constituent is adequately profiled and analyzed as follows.

2.2.1 Agricultural (Value Added) Exports

The traditional export sector in Nigeria consist of mainly agricultural/farm produce and is usually regarded as her traditional non oil export commodities (Onayemi and Ishola., 2009). These are cocoa, rubber, oil-palm, coffee, cotton, wood products, cassava, ginger, fish and shrimps

etc. Thus, it is important to mention that cocoa exports had pre-eminence as Nigeria's most exportable non-oil agricultural commodity (CBN 2015; NEPC 2013). However, the growing importance of global value chains in the international organisation of production increasingly challenges the traditional way of measuring a nation's export performance and hence international competitiveness (Frimpong, 2014; CBN 2015).

2.2.2 Manufactured Export

Frimpong (2014) argues that export of manufactured products is an essential route through which economic diversification could be achieved. The author added that it is also a key contributor to long term sustainable growth and poverty reduction as described by the theory of endogenous growth. Ayanwale (2007) notes that export of manufactures acts as a catalyst to transform the economic structure of countries, from simple, slow-growing and low-value activities to more productive activities that enjoy greater margins driven by technology and having higher growth prospects (Ajagbe et al., 2016; Adeogun, 2017; Iyoha and Oriahki, 2002; Abiso and Ajagbe, 2018). According to NEPC (2013), Nigerian manufactured exports to the international export market consists of textiles, chemical products, beer and beverages, urea-ammonia, insecticides, soap and detergents, plastics and non-metallic mineral products and processed skin etc.

2.2.3 Services Value Added Export

Shin et al. (2012) suggests that the factors influencing national growth has often been a subject of investigation in the economic literature, and recently the growth of China and India has brought this argument to the fore. The aforementioned countries have taken two different routes to achieve annual growth rates of nearly 7 percent. Though China has adopted a more traditional manufacturing-led growth approach, the growth strategy of India has been driven by expansion in the service sector (Cabral and Viegas, 2010; Shin et al., 2012). The Indian experience has motivated researchers to view the conventional notion that industrialization is the only feasible avenue to rapid economic development (Frimpong, 2014). Even though manufacturing sector has continued to be a dominant driver of growth, recent developments indicates that the service sector must be included in the discussion (Xu and Lu, 2007; Yonghui, 2003).

2.3 Economic Performance

Adeogun (2017) posited that economic performance is the assessment of an economy in relation to the achievement of her objectives. Ajagbe et al. (2015) stressed that the objectives could be long term, such as sustainable growth and development, or short term, such as the stabilization of the economy in response to sudden and unpredictable events, known as economic shocks. It has been rightly es-

tablished that export diversity is one of the critical indicators of economic performance as it enhances employment generation through the development of export oriented industries, increase foreign exchange earnings and improves balance of payment position of a given economy (Onayemi and Ishola, 2009; Frimpong, 2014). Some studies argued that sustainable increase in income per capita is better achieved under export promotion policy (Basu and Das, 2011; Iyoha and Oriahki, 2002; Onayemi and Ishola, 2009). Hence, the main objective of this study is to examine the effect of agricultural, manufactured and services (value added) on GDP per capita in Nigeria. In figure 1 which reveals the research conceptual framework, consisting of the relationship among agricultural, manufactured and services value added on GDP per capita which translates to economic performance in Nigeria.

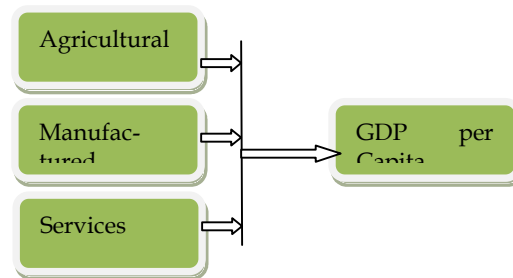

Figure 1: Research Conceptual Framework

3 METHODOLOGY

3.1 Theoretical Framework of the study

This study augmented the Standard Solow growth model (Adeogun, 2017). The Solow growth model assumes savings, population growth and technological progress as exogenous with two inputs in the form of capital and labour. A formal analytical framework for deriving the determinants of output performance in which export product diversification is included is developed. The initial step in the process is the specification of an explicit Cobb-Douglas production function of the usual form (Al-Marhubi, 2000). The study also in deriving the equation used incorporated relevant growth determinants variables such as major non-oil value added (Agriculture, Manufacturing and Services). This is done in order to underscore whether there are different effects for incorporating these macroeconomic series in modeling the relationship between export product diversification and output performance in Nigeria.

3.2 Measuring Export Diversification

In this study, Herfindahl-Hirschman index was used in line with previous studies (Al-Marhubi, 2000; Agosin, 2007; Hesse, 2008). The product diversification index in this study was computed using the Herfindahl-Hirschman procedure. Herfindahl-Hirschman Index (HHI) is the most widely used measure of output, trade and commodity diversification or concentration. For export product diversification, HHI is obtained thus;

$$HHI = \sqrt{\sum_{i=1}^N \left[\frac{x_i}{X} \right]^2} - 1 \quad \dots \dots \dots \quad (9)$$

Where, x_i is the export value of a specific product i , X is the Nigeria total export while N is the number of products. The formula ensures that the value of the HHI ranges from 0 to 1. A higher HHI indicates greater concentration or penetration to fewer products in Nigeria. Data on export product in Nigeria was obtained from World Integrated trade Solution (WITs, 2001) database using the number of products exported at the three-digit SITC level.

3.3` Estimation Techniques

This present study embraces a time series data in Nigeria within a framework of theoretical linear autoregressive distributed lag model (ARDL). The model of ARDL helps researchers to capture both linear effect in the non-oil export product diversification relationship in both short run and long run (Asika, 2004; Adeogun, 2017). The study performs analysis at three different level of estimation to include; pre-estimation, model estimation and post estimation analysis. Preliminary tests would be performed before the main estimation of the model. This includes the uses of descriptive tests (including mean, median, mode and standard deviation), skewness and kurtosis of the series (Asika, 2004). Finally, Jarque-bera test statistic is used to establish the normality features of the series. Also, standard unit root and correlation analysis was performed in order to determine the stationarity and whether we can include all the series in a single estimable model. This study performs a test for the presence of co-integration among the variables using a bounds testing approach (Pesaran et al., 2001; Shin et al., 2012). Thereafter, the estimation of ARDL was done to determine both short and long-run estimable model. Then the study performed the Wald test of the null hypothesis $\omega_0 = \omega_1 = \omega_2 = \omega_3 = 0$ to Short-run additive linear relationship. Also, we check the goodness of fit for the bounds through stability tests such as cumulative sum (CUSUM) and cumulative sum squares (CUSUMSQ). In addition, a number of post estimation diagnostic tests are conducted to include serial correlation test, linearity test, heteroskedasticity and the Autoregressive Conditional Heteroskedasticity (ARCH) effect. The hypothesis of this study was tested at 0.05 level of significance. H_{01} : Agricultural, manufacture and services (value added) have no significant effect on Gross Domestic Product per capita.

4 DATA ANALYSIS

Results of the descriptive analysis of the variables used in the regression analysis shows the mean, standard deviation, skewness and kurtosis coefficients and the Jarque-

Bera statistics to test the null hypothesis that all our variables are normally distributed among others. It is found that variability is highest for GDP per capita (GDPPC), but lower for Agricultural value added (AGRIC), Manufacturing (MAN) and Services value addition (SER) respectively. However, all the series are positively skewed except our measure of diversification, agriculture and manufacturing value added, that are negatively skewed and the Jarque-Bera statistics reject the null hypothesis of normality for SER at statistical significant level. Moreover, the Jarque-Bera statistics of other series accept the null hypothesis of normality. However, the pairwise correlation analysis of the variables used in the estimation is important to establish the level of association between GDP per capita and other determinants variables which has implication for their inclusion in the same model (Papageorgiou and Spatafora, 2012; Pesaran et al., 2001). The results suggest that the correlation coefficient between the variables are moderate and can co-exist in the same model. The results of the correlation analysis exert both positive and negative signs and coefficient for all variables. Specifically, GDP per capita (GDPPC), manufacturing (MAN) and services value added (SER) all exerts a moderate negative relationship with agricultural value added (AGRIC). Also, the estimated correlation result for Nigeria shows that only agricultural value added (AGRIC) exerts a positive relationship with non-oil export product diversification over the estimated period. Interestingly, services value added (SER) also depict a positive relationship with output per capita (GDPPC) in Nigeria.

In this study, the standard unit root test are conducted in order to determine the stationarity of all variables used in the regression analysis. The unit root test is conducted using both Augmented Dickey-Fuller (ADF) test and Phillips-Perron. The result shows that none of the series is of higher integrated of I(2). Test for stationarity shows that all variables are integrated of order I(1). Following from the theoretical framework and the results of the unit roots in the direction of mixture of stationarity – which justified the uses of autoregressive distributed lag model. This study proceeds to estimate different model based on the objective of the study. Moreover, under different estimated models, some variables were excluded in order to avoid the collinearity problem that is associated with some of them. Therefore, the results obtained from the analysis are presented based on the objective stated as follows.

5 DISCUSSIONS OF FINDINGS

Effect of Agricultural, Manufactured and Services (value added) on GDP per Capita

Proceeding to the co-integration test for the objective of the study; the empirical result from the bounds test co-integration for the effect of agricultural, manufactured and services value added on GDP per capita in Nigeria is

presented in table 1 below. The result reveals the computed F-Statistics for Wald test to be 13.97 on approximation. The value exceeds both the upper bounds and lower bounds critical values for all level of significance. Therefore, the statistics test yields evidence of a long-run relationship between agricultural, manufactured, services value added, GDP per capita at all levels of significance in Nigeria.

Table 1: Bounds Testing for Co-integration Analysis

Computed Wald F-Statistic: 13.9685 (AIC Lags = 1)		
Bounds level:	Lower I(0):	Upper I(1):
1% critical bounds value	2.65	3.97
5% critical bounds value	2.14	3.30
10% critical bounds value	1.88	2.99
Notes: for the Wald F-Statistic; Asymptotic critical value bounds are obtained from Table C1 (iii) Case III: unrestricted intercept and no trend for k = 9 (Pesaran et. al., 2001, pg. 300).		

Source: Author’s computation

Hence the null hypothesis of no co-integration is rejected and long-run co-integration relationship is established among the variables in this model. In the ARDL results obtained from the empirical analysis of the effect of agricultural, manufactured and services value added on GDP per capita in Nigeria. The dependent variable is the logarithms of GDP per capita while the independent variables are the logarithms of AGRIC, MAN and SER. All variables were logged and estimation period is from 1981-2015. Looking at the model's post estimation diagnosis tests, the residual series are normally distributed as suggested by the Jarque–Bera statistics, while the Breusch–Godfrey LM test statistics indicate that the model does not have significant serial correlation problem. Moreover, the ARCH test and the Ramsey RESET test respectively show that the residuals are homoscedastic and the model has correct functional form. The results of the long-run and short-run ARDL model on the impact of agriculture, manufacture and services value added on output performance were also tested. The long-run results reveal that the coefficient of agriculture value added is statistically insignificant, even though the sign of the coefficients of the variables is negative. The results show that the effect of services value added on GDP per capita is positive and insignificant, while the impact of manufacturing value added is negative and significant. Thus, a 1.0% rise in services value added raised the level of growth by about 0.125%. The short-run ARDL model shows that the major factor for the high growth of economic performance was manufacturing value added, while agricultural value added, is less important in driving growth process. Thus, 1.0% increase in past value of manu-

factured value addition leads to about 0.244% rise in total growth. In general, the fit of the regression equations in this study is quite good ($R^2 = 0.99$ and adjusted $R^2 = 0.99$) as can be seen in the study analysis. The R-squared shows that all the independent variables in our model explain approximately 99% of the variations in growth process in Nigeria (dependent variable) in the period under consideration. Also, the joint F-test statistic was found significant (0.0004) at 1%, showing the test for testing jointly the independent variables. Pertinent to the above, the Durbin-Watson (DW) statistic (measure for the presence of autocorrelation in the model) is 3.369, it is noticed therefore, that our model is free from autocorrelation as the value is above 2. This means that the model is reliable in explaining the dynamics between agricultural, manufactured, services value added and GDP per capita in Nigeria. This results are consistent with the findings of Ayanwale (2007) that export of manufactures acts as a catalyst to transform the economic structure of countries, from simple, slow-growing and low-value activities to more productive activities that enjoy greater margins driven by technology and having higher growth prospects (Ajagbe et al., 2016; Adeogun, 2017; Iyoha and Oriahki, 2002).

6 CONCLUSION AND RECOMMENDATIONS

This study examined the type and strength of the relationship that exists between non-oil exports diversification and growth performance in Nigeria between the period of 1981 and 2015. The results of the long-run and short-run ARDL model on the impact of agriculture, manufacture and services value added on output performance reveal that the effect of services value added on GDP per capita is positive and insignificant, while the impact of manufacturing value added is negative and significant. The short-run ARDL model showed that the major factor for the high growth of economic performance was manufacturing value added, while agricultural value added, is less important in driving growth process in Nigeria while a deviation from the long-run equilibrium is corrected for on a yearly basis. Interestingly, the impact of non-oil export product diversification on output performance recorded a positive significant effect on growth in Nigeria. This study suggests that there should be further consolidation of Nigeria’s traditional sectors with greater emphasis still being placed on the production of higher-value-added products, which entails investment in modernizing the technology base for these sectors. Hence, future studies should identify further economic performance variables with respect to specific countries and consider how these variables play their roles for better economic performance.

7 REFERENCES

- [1] Abiso, K. A. and Ajagbe, A. M. (2018). Adoption of Electronic Commerce Technology in Emerging Nations: A Conceptual Review of the Literature. *International Journal of Economics, Commerce and Management*, UK. Vol. VI, Issue 2, Pp. 455-472.
- [2] Adeogun, O. S. and Ajagbe, A. M. (2018). Evaluate the Effect of Human Capital and Financial Development on Output Growth in Nigeria. *International Conference on Global and Emerging Trends*. A conference organized by Universiti Teknologi Malaysia and Baze University, Abuja. May, 2-4, 2018.
- [3] Adeogun, O. S. (2017). Export Diversification and Economic Performance: A Study of Nigerian Non Oil Export. PhD Dissertation Submitted to Babcock University School of Post Graduate Studies.
- [4] Ajagbe, A. M., Olujobi, J. O., Uduimoh, A. A., L. U. Okoye and Oke, O. A. (2016). Technology based entrepreneurship financing: lessons for Nigeria. *International Journal of Academic Research in Accounting, Finance and Management Sciences*, 6(1), 150-163.
- [5] Ajagbe, A. M., K. Ismail and D. T. Isiavwe and Ogbari, E. I. M. (2015). Barriers to technological and non-technological innovation activities in Malaysia. *European Journal of Business and Management*, 7(6), 157-168.
- [6] Ajagbe, A. M. and Ismail, K. (2014). Factors Influencing Venture Capital Assessment of High Growth Companies in Malaysia. *International Journal of Entrepreneurship and Small Business*, 21(4), 457-494.
- [7] Ajagbe, A. M., Ismail, K., Aslan, A. S. and Choi, S. L. (2012). Investment in technology based small and medium sized firms in Malaysia: Roles for commercial banks. *International Journal of Research in Management and Technology*, 2(2), 147-153.
- [8] Asika, N. (2004). "Research Methodology in the Behavioural Sciences: Lagos.
- [9] Ayanwale, A. B. (2007). "FDI and economic growth: Evidence from Nigeria". *African economic research consortium, Nairobi AERC Research Paper*, 165.
- [10] Al-Marhubi, F. (2000). "Export diversification and growth: An Empirical Investigation", *Applied Economics Letters*, 7(9), 559-562.
- [11] Agasha, N. (2009). Determinants of export growth rate in Uganda 1987-2006, *Uganda Revenue Authority, Research and planning in Uganda*, 3, 22-29.
- [12] Agosin, M. (2007). "Export diversification and growth in emerging economies", *serie documentos de Trabajo N 233, Universidad de Chile, Santiago*.
- [13] Barthelemy, J. C. and Chauvins, S. (2000). "Structural changes in Asia and growth prospects after the crisis" *CEPII working papers*, 00-09, 12-17
- [14] Basu, S. R. and Das, M. (2011). Export structure and economic performance in developing countries: Evidence from Non-parametric Methods, policy issues in *International Trade and Commodities study series*, 48, 19.
- [15] Cabral, C. and Viegas, P. (2010). Determinants of Export Diversification and Sophistication in Sub-Saharan Africa, *NBER project on African development*.
- [16] CBN (2015). *Statistical Bulletin*. Central Bank of Nigeria.
- [17] Frimpong, A. O. (2014). Entrepreneurship and export performance, *African Journal of Economic Development*, 5(7), 63-69
- [18] Iyoha, M. A. and Oriahki, D. E. (2002). Explaining African economic growth performance "The case of Nigeria" A revised interim report on Nigeria. *The African Economic Research Consortium, May, 2002*.
- [19] NEPC (2013). "Export incentives in Nigeria", *Federal Government Printing Press, Lagos, Nigeria*.
- [20] Onayemi, S. O and Ishola, A. R. (2009). Diversifying the productive base of Nigeria, an Econometric approach to the assessment of Non-Oil Export Promotion Strategies, *International Research Journal of Finance and Economics*, 33-39
- [21] Papageorgiou, C. and Spatafora, N. (2012). *Economic diversification for stability and growth in LICs, IMF Working Paper*.
- [22] Pesaran, H. M., Shin, Y. and Smith, R. J. (2001). Bounds Testing Approaches to the Analysis of Level Relationships. *Journal of Applied Economics*, 3(7), 29-38.
- [23] Shin, Y., Jo, H., Lee, S., Kim, Y., Hong, Y. and Chang, K. (2012). Analysis of Anti-Oxidant Activity of Medicinal Plants according to the Extracted Parts. *Journal of Medicinal Plant Research*, 6, 4615-4624.
- [24] Spence, M., Karingi, S. and Mevel, S. (2012). *Export diversification and intra- industry trade in Africa, United Nations Economic Commission for Africa, June, 2012*.
- [25] WITS (2001). *Data on Export Product in Nigeria. World Integrated Trade Solution*.
- [26] Xu, B. and Lu, J. (2007). The impact of foreign MNEs on export sophistication of host countries; evidence from China, *China Europe International Business School*
- [27] Yonghui, X. (2003). The changing of international textiles and clothing market and the countermeasures of China's textiles industry, *Social Science Frontier. Changchun*, 15(6), 27-33.

Evaluate the Effect of Human Capital and Financial Development on Output Growth in Nigeria

Simeon Olubukola Adeogun¹ and Musibau Akintunde Ajagbe^{2*}

Multipro Consumer Products Limited, Lagos, Nigeria.

Faculty of Management Sciences, Durban University of Technology, RSA

**ajagbetun@gmail.com*

Abstract- This study evaluates the effect of human capital and financial development on output growth in Nigeria. The results from the long-run and short-run ARDL model on the impact of effect of human capital and financial development on output performance indicated that the effect of human capital development on GDP per capita is negative and significant which, infer the absence of effective human capital development in Nigeria. Financial development measured by domestic credit to private sector impact positively on growth and therefore, an increasing financial development in the country has had positive effect on growth. In the short-run however, results shows that the major factor for the high growth of economic performance was past value of capital invested, amount of labour supply in the economy, and financial development, while present training in human capital development is less important in driving growth process, while stressing the important role for financial development and human capital development in growth performance in Nigeria. Hence, policy efforts should be given to improve R&D expenditure, skill enhancement, more innovation activities, and liberalization of FDI inflows. Findings from this study offer excellent opportunity for the government to market the country as a platform for reinvestment in the region.

Keyword— Export Diversification, Human Capital, Financial Development, Output Growth, Economic Performance.

1. INTRODUCTION

The background of this research consists of a brief review of literature on export diversification. The study also discusses the dimensions of export diversification such as; investment, human capital, openness, innovation and R&D, economic policies and macroeconomic conditions, political factors, socio-cultural factors, foreign direct investment, institutional framework, geography, demography and population. However, among the aforementioned dimensions, just four most important and relevant to the study title will be elaborated on. In addition, the impact of the investigated variables such as human capital and financial development on economic performance, as measured by output growth was also examined. In the next section of this study is the methodology, followed by the research analysis, discussion of results, and conclusion of the study. Thus, the main objective of this study is to evaluate the effect of human capital and financial development on output growth in Nigeria.

2 BACKGROUND TO THE STUDY

Adeogun (2017) described the term export diversification as an alteration in the composition of a country's existing export product mix or destination. The concept has also been viewed by Berthelemy and Chauvin (2000) as the spread of production over many sectors. Thus, for many developing countries, and as part of an export led growth strategy, export diversification is conceptualized as an evolution from traditional to non-traditional export strategy.

However, a strong, growing and sustainable economy is the goal of every nation (Brenton and Newfarmer, 2009; Al-Marhubi, 2000; Agosin, 2007). Since Adam Smith's pioneering investigation into the nature and causes of the wealth of countries, the relevance of foreign business to a countries to economic wellbeing and growth has been strongly investigated in the economics literature (Easterly and Reshelf, 2010; Edwik, 2007). This mindset is important because nations are expected to export product and services in order to realize incomes to finance imported products and services which cannot be produced domestically. Edwik (2007) documents that diversification of export base of nations with liberalization of trade, integration and competition among world economies, remain one of the main growth determinants among countries. This is so because it forms the basis for economic health of nations and substantially adds to employment, trade balance, economic growth, and enhanced living standard (Adelegan, 2000; Abou-Strait, 2005; Abu-Qarn and Suleiman, 2010). The role and importance of export diversification on economic performance cannot be over emphasized. Export trade plays a vital role in the growth of any economy just as reports that foreign trade is highly beneficial to a nation as it helps in increasing the level of aggregate economic activities through its multiplier effects on the level of national income. Edwik (2007) opines that export portfolio is one of the several catalysts of productivity and growth and hence its contribution is contingent on its weight in the aggregate economic activity. Adelegan (2000) stresses that export basket equally plays a key role in achieving sustainable growth because of improvement of financial position, increased capacity utilization, higher technological

standards, and attainment of a desired performance (Hoag and Hoag, 2006; Ajagbe and Ismail, 2014). It can be an engine for the nation's economic growth as it mobilizes other factors of production; the renewable and non-renewable resources of nature.

CBN (2015) submits that Nigeria's extremely large petroleum and allied natural resources base have proven to be the bane of her political instability, endemic corruption, economic non-performance and social stagnation. Many authors and public commentators have argued that Nigeria's crude oil has become its curse. As it is believed that the crude oil curse is the perspective of the globally recognized problem that countries with abundant deposit of natural resources tend to always lag behind countries with little natural resources deposit (Brenton and Newfarmer, 2009; Al-Marhubi, 2000; Agosin, 2007). Nonetheless, Brenton and Newfarmer (2009) articulates that a convincing case for low income countries to diversify their economies as to avoid the pitfalls by speeding up of the non-oil growth and job creation, the crude oil revenues should be used strategically with the aim of facilitating the transition to competitive market-led economy. Enhancing the quality of Nigeria's human resources (Bilau et al., 2015a; Bilau et al., 2015b) will also be essential to improve productivity and diversify the economy and become competitive.

Basu and Das (2011) argues that enhancing the standard of governance requires unique effort because it underlies the economic reform agenda of any nation. The continued unimpressive performance of the Nigerian non-oil sector and the vulnerability of the external sector thus dictate the urgent need for a reappraisal of the thrust and content of the economic performance measures and commitments to their implementation (Abiso and Ajagbe, 2018; Hoag and Hoag, 2006). Indeed the need for a change in the policy focus and a shift in the industrialization strategy is imperative if Nigerian economy is to be returned to the path of sustainable growth and external visibility. The mono product nature of the Nigerian economy coupled with fluctuations in international price of crude oil have in no small measure stalled her various development efforts (Onodugo et al., 2013; Soludo, 2007). Thus, researchers both locally and internationally have observed that a factor crucial to the lack of economic progress in Nigeria is the lack of economic diversity which has caused the economy to rely heavily on crude oil for revenues and as the major export commodity in the economy. Therefore, an investigation of the relationship between human capital and financial development on output growth performance in Nigeria is pertinent. In view of this, the main objective of this study is to evaluate the effect of human capital and financial development on output growth in Nigeria.

2.1 Determinants of Economic Performance

Extant researches have explored various factors determining economic performance (Barthelemy and Chauvins, 2000; Adeogun, 2017; Abiso and Ajagbe, 2018). With the adoption of various conceptual and methodological standpoints, such studies laid emphasis on a wide set of explanatory parameters and offered different insights to the sources of economic performance. However, for the purpose of this study, human capital, innovation and R&D,

investment, and foreign direct investment will be discussed.

2.1.1 Investment: Ayanwale (2007) argues that financial investment is the most essential determinant of economic growth recognized by growth models of various researchers. Nonetheless, Ajagbe et al. (2012) posits that the relevance attached to financial investment by these authors has resulted to a substantial volume of empirical works assessing the linkage between financial investment and economic growth.

2.1.2 Human capital: Basu and Das (2011) stresses that human capital is also an important source of growth in various endogenous growth models. It is also perceived as one of the main extensions of the neoclassical growth model. Barthelemy and Chauvins (2000) opines that since the concept refers chiefly to workers' acquisition of skills and know-how through education and training, the majority of studies have measured the quality of human capital using proxies related to education (school-enrolment rates, tests of mathematics and scientific skills). A large number of studies have found evidence suggesting that educated population is key determinant of economic growth (Bilau et al., 2015a; Bilau et al., 2015b).

2.1.3 Innovation and R&D: In the entrepreneurship literature, Ajagbe and Ismail (2014) finds that innovation and research and development efforts could be perceived as essential in economic progress measured in terms of increasing productivity and growth. The authors adds that it is as a result of rising adoption of technology (Abiso and Ajagbe, 2018), which allows introduction of new and superior products and processes. This role has been stressed by various endogenous growth models, and the strong relation between innovation/R&D and economic growth has been empirically supported by some authors (Agosin, 2007; Ajagbe et al., 2015; Abiso and Ajagbe, 2018).

2.1.4 Foreign Direct Investment (FDI): The role played by FDI in internationalizing economic activity and as an important source of technology transfer and economic growth has been identified (Ajagbe and Ismail, 2014). This important role is emphasized in many theories of endogenous growth. Extant studies evaluating the impact of FDI on growth has found almost similar results confirming a significant positive link between the two (Ayanwale, 2007; Adeogun, 2017). Figure 1 shows the relationship among human capital and financial development as independent variables on output growth as dependent variable.

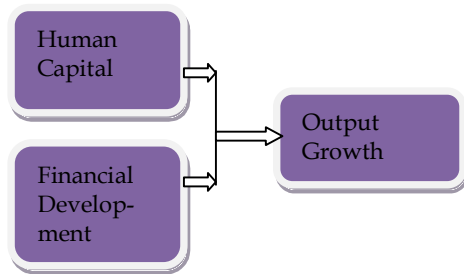

Figure 1: Research Conceptual Framework

3 METHODOLOGY

The Solow growth model that was used in this study assumes that savings, population growth and technological progress are exogenous inputs in the form of capital and labour (Adeogun, 2017). A formal analytical framework for deriving the determinants of output growth in which export product diversification is included is developed. The initial step in the process is the specification of an explicit Cobb-Douglas production function of the usual form (Al-Marhubi, 2000). The study also in deriving the equation used incorporated relevant growth determinants variables (human capital, financial development, output growth). This is done in order to underscore whether there are different effects for incorporating these macroeconomic series in modeling the relationship between human capital and financial development on output growth in Nigeria.

In this study, Herfindahl-Hirschman index was used in line with previous studies (Al-Marhubi, 2000; Agosin, 2007; Hesse, 2008). The product diversification index in this study was computed using the Herfindahl-Hirschman procedure (WITs, 2001)

This study embraces a time series data in Nigeria within a framework of theoretical linear autoregressive distributed lag model (ARDL). The model of ARDL helps researchers to capture both linear effect in the non-oil export product diversification relationship in both short run and long run (Asika, 2004; Adeogun, 2017). The study performs analysis at three different level of estimation to include; pre-estimation, model estimation and post estimation analysis. Preliminary tests would be performed before the main estimation of the model. This includes the use of descriptive tests (including mean, median, mode and standard deviation), skewness and kurtosis of the series (Asika, 2004). Finally, Jarque-bera test statistic is used to establish the normality features of the series. Also, standard unit root and correlation analysis was performed in order to determine the stationarity and whether we can include all the series in a single estimable model. This study performs a test for the presence of co-integration among the variables using a bounds testing approach (Pesaran et al., 2001; Shin et al., 2012). Thereafter, the estimation of ARDL was done to determine both short and long-run estimable model. Then the study performed the Wald test of the null

hypothesis $\omega_0 = \omega_1 = \omega_2 = \omega_3 = 0$ to Short-run additive linear relationship. Also, we check the goodness of fit for the bounds through stability tests such as cumulative sum (CUSUM) and cumulative sum squares (CUSUMSQ). In addition, a number of post estimation diagnostic tests are conducted to include serial correlation test, linearity test, heteroskedasticity and the autoregressive conditional heteroskedasticity (ARCH) effect. The hypothesis of this study was tested at 0.05 level of significance. H_{01} : There is no significant effect of human capital and financial development on output growth in Nigeria.

4 ANALYSIS AND DISCUSSION OF RESULTS

4.1 Descriptive Statistics and Correlation Analysis

Results of the descriptive analysis of the variables used in the regression analysis are reported. The result shows the mean, standard deviation, skewness and kurtosis coefficients and the Jarque-Bera statistics to test the null hypothesis that all our variables are normally distributed among others. It is found that variability is highest for Labour, GDP per capita, but lower for financial development and human capital respectively. However, secondary school enrolment and non-oil export product diversification has the lowest variability with a standard deviation of about 0.211 and 0.003. All the series are positively skewed except our measure of diversification. Also secondary school enrollment was negatively skewed and the Jarque-Bera statistics reject the null hypothesis of normality for financial development, human capital, and output growth at different statistical significant level. Moreover, the Jarque-Bera statistics of other series accept the null hypothesis of normality.

The results of the correlation analysis are important to establish the level of association among the variables used in the regression analysis. The analysis is particularly important in order to determine the type of association between human capital, financial development, GDP per capita and other determinants variables which has implication for their inclusion in the same models. The results suggest that the correlation coefficients between and among these variables are moderate and can co-exist in the same model. The results of the correlation analyses exert both positive signs and coefficient for all variables. Interestingly, human capital and financial development depict a positive relationship with output per capita in Nigeria.

4.2 Effect of Human Capital and Financial Development on Output Growth

The empirical result from the bounds test co-integration for the effect of human capital and financial development on GDP per capita in Nigeria is presented in table 1. The result reveals that the computed F-Statistics for Wald test is 5.10 on approximation. The value exceeds both the upper bounds and lower bounds critical values for all level of

significance. Therefore, the statistics test yields evidence of a long-run relationship between human capital, financial development and other included variables at all levels of significance in Nigeria.

Table 1: Bounds Testing for Co-integration Analysis

Computed Wald F-Statistic: 5.1038 (AIC Lags = 1)		
Bounds level:	Lower I(0):	Upper I(1):
1% critical bounds value	3.15	4.43
5% critical bounds value	2.45	3.61
10% critical bounds value	2.12	3.23

Notes: for the Wald F-Statistic; Asymptotic critical value bounds are obtained from Table C1 (iii) Case III: unrestricted intercept and no trend for k = 6 (Pesaran, et. al 2001, pg. 300).

Hence the null hypothesis of no co-integration is rejected and long-run co-integration relationship is established among the variables in this model. However, the ARDL results obtained from the empirical analysis of the effect of human capital and financial development on GDP per capita. The dependent variable is the logarithms of GDP per capita while the independent variables are the logarithms of human capital, financial development and output growth. In general, the fit of the regression equations is quite good ($R^2 = 0.98$ and adjusted $R^2 = 0.96$) as can be seen from the table 1. The R-squared shows that all the independent variables in our model explain approximately 98% of the variations in growth process in Nigeria (dependent variable) in the period under consideration. Also, the joint F-test statistic was found significant (0.0000) at 1%, showing the test for testing jointly the independent variables. Pertinent to the above, the Durbin-Watson (DW) statistic (measure for the presence of autocorrelation in the model) is 2.63, it is noticed therefore, that our model is free from autocorrelation as the value is above 2. This means that the model is reliable in explaining the dynamics between human capital development, financial development and GDP per capita in Nigeria.

5 CONCLUSION AND RECOMMENDATIONS

This study values the effect of human capital and financial development on output growth in Nigeria. The results from the long-run and short-run ARDL model on the impact of effect of human capital and financial development on output performance indicated that the effect of human capital development on GDP per capita is negative and significant which, infer the absence of effective human capital development in Nigeria. Financial development

measured by domestic credit to private sector impact positively on growth and therefore, an increasing financial development in the country has had positive effect on growth. In the short-run however, results shows that the major factor for the high growth of economic performance was past value of capital invested, amount of labour supply in the economy, and financial development, while present training in human capital development is less important in driving growth process, while stressing the important role for financial development and human capital development in growth performance. Hence, policy efforts should be given to improve R&D expenditure, skill enhancement, more innovation activities, and liberalization of FDI inflows. Findings from this study offer excellent opportunity for government to market the country as a platform for reinvestment in the region.

6 REFERENCES

- [1] Adeogun, O. S. (2017). Export Diversification and Economic Performance: A Study of Nigerian Non Oil Export. PhD Dissertation Submitted to Babcock University School of Post Graduate Studies.
- [2] Abiso, K.. A. and Ajagbe, A. M. (2018). Adoption of Electronic Commerce Technology in Emerging Nations: A Conceptual Review of the Literature. International Journal of Economics, Commerce and Management, UK. Vol. VI, Issue 2, Pp. 455-472.
- [3] Ajagbe, A. M., K. Ismail and D. T. Isiavwwe and Ogbari, E. I. M. (2015). Barriers to technological and non-technological innovation activities in Malaysia. European Journal of Business and Management, 7(6), 157-168.
- [4] Ajagbe, A. M. and Ismail, K. (2014). Factors Influencing Venture Capital Assessment of High Growth Companies in Malaysia. International Journal of Entrepreneurship and Small Business, 21(4), 457-494.
- [5] Adelegan, J. O. (2000). "Foreign direct investment and economic growth in Nigeria: A seemingly unrelated model". African Review of Money, Finance and Banking, Supplementary issues on "Savings and Development" 2000, Milan.
- [6] Abou-Strait, F. (2005). Are exports the engine of economic growth? an application of co-integration and causality analysis for Egypt, 1977-2003. African Development Bank, *Journal of African Economic Review*, 12(3), 24-29.
- [7] Abu-Qarn, A.S, and Suleiman A. (2010). Export led Growth: empirical evidence from the MENA region. Ben Gurion University, Monuster, *Center for Economics Research*, 1-34.
- [8] Ajagbe, A. M., Ismail, K., Aslan, A. S. and Choi, S. L. (2012). Investment in technology based small and medium sized firms in Malaysia: Roles for commercial banks. International Journal of Research in Management and Technology, 2(2), 147-153.
- [9] Asika, N. (2004). "Research Methodology in the Behavioural Sciences: Lagos.

- [10] Ayanwale, A. B. (2007). "FDI and economic growth: Evidence from Nigeria". African economic research consortium, Nairobi AERC Research Paper, 165.
- [11] Al-Marhubi, F. (2000). "Export diversification and growth: An Empirical Investigation", *Applied Economics Letters*, 7(9), 559-562.
- [12] Agosin, M. (2007). "Export diversification and growth in emerging economies", serie documentos de Trabajo N 233, Universidad de Chile, Santiago.
- [13] Basu, S.R. and Das M (2011). Export structure and economic performance in developing countries: Evidence from Non-parametric Methods, policy issues in International Trade and Commodities study series, 48, 19.
- [14] Barthelemy, J. C. and Chauvins, S. (2000). "Structural changes in Asia and growth prospects after the crisis" CEPPI working papers, 00-09, 12-17.
- [15] Brenton, P. and Newfarmer, R., (2009). Watching more than the discovery channel to diversify exports in R. New farmer, W. Shaw and P. Walkenhorst (eds.), *Breaking into New Markets: Emerging Lessons for Export Diversification*, World Bank, Washington DC.
- [16] Bilau, A. A., Ajagbe, M. A., A. S. Bustani, S.A., and Sholanke, A. B., (2015a). Review of absorptive capacity in small and medium sized construction firms in Nigeria. *Journal of Developing Country Study*, 5(16), 52-61.
- [17] Bilau, A. A., Ajagbe, M.A., Bustani, A.S., and Sani, T.A., (2015b). Absorptive capacity for firms development: Impending factors for small and medium sized construction firms. *Journal of Civil and Environmental Research*, 7(8), 12-25.
- [18] CBN (2015). Statistical Bulletin. Central Bank of Nigeria.
- [19] Easterly, W. and Reshelf, A. (2010). "African export successes: Surprises, stylized facts, and explanations", NBER Working Paper No16597, *National Bureau of Economic Research, Inc.*
- [20] Edwik, A.A., (2007). Oil dependency, economic diversification and development. A case study of Libya, PhD Thesis, University of Salford, United Kingdom, 46-50
- [21] Hesse, H. (2009). "Export diversification and economic growth", In *breaking into new markets, emerging lessons for export diversification*, R. New farmer, W. Shaw, and P. Walkenhorst (eds.), Washington DC: The World Bank, 55-80.
- [22] Hoag, A. J. and Hoag, J. H. (2006). Trade without money, In A. J. Hoag, and J. H. Hoag, *Introductory Economics* (4 ed., p. 520)., Singapore: World Scientific Publishing Co. Pty Ltd.
- [23] Onodugo, V. A., Ikpe, M. and Anowor, O. F. (2013). Non-oil export and economic growth in Nigeria: A time series econometric model, *International Journal of Business Management and Research*. 3 (2): 115-124.
- [24] Pesaran, H. M., Shin, Y. and Smith, R. J. (2001). Bounds Testing Approaches to the Analysis of Level Relationships. *Journal of Applied Economics*, 3(7), 29-38.
- [25] Soludo, C.C. (2007). Macroeconomic, monetary and financial sector developments on financial and payment system reforms in the country, *Economic and Financial Review*, 30(1), 32-69.
- [26] Shin, Y., Jo, H., Lee, S., Kim, Y., Hong, Y. and Chang, K. (2012). Analysis of Anti-Oxidant Activity of Medicinal Plants according to the Extracted Parts. *Journal of Medicinal Plant Research*, 6, 4615-4624.
- [27] WITS (2001). Data on Export Product in Nigeria. World Integrated Trade Solution.

A Literature Review of Employee Motivation

Wu Yuping*

¹Faculty of Management, University Technology Malaysia, Malaysia

* 1615682474@qq.com

*Abstract---*With the development of globalization, there are many companies meet new challenges, employee work inefficiency, high turnover rate, which result in whole organization fall down. Motivation is very important factors that make employee work efficiency. So learn how to motivate employee is becoming more and more important. This article mainly talk about the importance of motivate employee. According to literature review and related theory, make a contribution for company how to motivate employee and conclude better suggestion, give some critical comments in order to support some advise to some companies.

Key words: challenges, development, employee, motivation

1. INTRODUCTION

Motivation play an important role in an organization, which have many different styles, ways, theories guide individual, group as well as organization have a high performance and effective work. In the modern society, more and more people work in the different style organization, and with a rate competition, the most of people still have high passion to work within high-pressure and tension work environment Motivation. However, the one who work hard maybe so exhausted that bad for their health and sacrifice themselves. So the main reason is they will continue to work hard and don't care about their growth of body and mind. In this article,I will review others article and have the conclusion about the motivation .Firstly, I will find the definition and mainly described the introduction about motivation, which including the reason why motivation is indispensable in part of organization; secondly, I reviewed relevant article about motivation and conclude the main point, compared with each other and come to the difference among those article. Thirdly, I listed several motivation theory in order to go a step further in understand the importance of motivation. Finally, I make a conclusion for those motivation standpoint and give my critical analysis of how to improve employee's work efficiency. Through review these motivation articles,I could better understand the process and importance of motivation as well as which way is correct way to motivate the employee in organization. And I will have more new view about motivation and more significant for my further study.

2 DEFINITION

Motivation has different definition in different research filed. Psychology is generally considered to involve the beginning, direction, intensity, and continuity of behavior.In organizational behavior, motivation mainly refers to the psychological process of stimulating people's motivation. By stimulating and encouraging, people can create an internal driving force and make them move towards the desired goal. Its the power that drives people to act. And

the motivation is to promote people to engage in certain activities, and the internal power towards one direction.The reason is the action to achieve a certain purpose. Motivation is the internal process of individual behavior, behavior is the performance of internal process. Internal conditions caused by motivation is the need, motivation caused by external conditions is the external factors driving organism incentive. Motivation is the reason for people's actions, desires, and needs. Motivation is also one's direction to behavior, or what causes a person to want to repeat a behavior. A motive is what prompts the person to act in a certain way, or at least develop an inclination for specific behavior. According to Ruth Kanfer a(2016), "Motivation is a word that is part of the popular culture as few other psychological concepts are."

All the definition of motivation referred psychological activities, including desire, action, needs and then influence people's behavior. So motivation is very important, which can effect human's behavior from internal factor.

3 IMPORTANCE OF MOTIVATION

Motivation has three functions to human action, the first one is activating function, which guide people's action and leads to a certain action. Especially in a group or organization, the leader play an important role in how to guide employee to have high passion work hard. The second one is strengthening function; motivation can maintain and adjust this action; when some employee have high stress or encounter frustrate,and don't have better motivation to work, then the manager could take measures to make the employee keep their motivation for work. The last one is pointing function, that lead the action to forward a certain goal under the influence of motivation. Therefore, motivation can make employee more activity and strengthen their motive during the work. Motivation is very meaningful in whole work process.

According to Stefania Zlatea (2015), First of all, during the management process, motivation is a vital part of the general management process and the integrating component of the performance management. Some theories offers to managers more clues concerning people's motivation.

Some managers pay attention to finding appropriate methods based on these tips to motivate the workers. When we have these ways of motivating employee, and this situation also applies to educational organizations which play an important role for development of the community. Secondly, educational organizations have a quite importance for the countries. And studies on the relationship between education and development also show that education has an important role in the development of countries. The employee's motivation have related with education. Hence the one who keep the workers have good motivation could provides quality and efficient operation for these organizations, which laying good foundations for future education development. Further more, entire education managers from Minister of Education to the school principals have an important role. They expected to recognize the various aspects of the workers of the educational organizations identify their needs and determine their motivation conditions and provide these conditions in the light of domestic and foreign scientific researches, the most important is that they supply the condition of promote motivation in order to play a positive role in education. Whatever country or individuals, groups, organizations, education is an indispensable part of life, so focus on the development of education and know the conditions of motivation, which is good for work quality.

4. LITURATURE REVIEW

In Ruth Kanfer (2016) ,this article mainly talk about the motivation in organizational behavior reviewed early the history of motivation and advances as well as prospects. What is the motivation during the process of choosing and establishing goal, based on this question the article choose the most impactful articles and and summarize research progress in order to better understand this question and also referred the macro-level trends in motivation research, including the core theories of work motivation, examine key micro-regulatory processes involved in goal decisions and goal pursuit and look forward to concluding with discussion of promising future research directions.

Jim Naylor and George Briggs(1996),introduced the purpose of organizational behavior and human performance as a journal aimed at publishing significant research that contributes to our basic knowledge of human performance.Over the past 50 years, the journal has published seminal papers on the determinants, mechanisms, and outcomes of motivation related to decision-making and performance in work and achievement settings. Another theory including Ajzen's Theory of Planned Behavior (1991), Deci's Cognitive Evaluation Theory (1972), Hackman and Oldham's Job Characteristics Model (1976), and Locke's Goal Model (1968). Other articles provide incisive reviews and critiques. As the 20th century drew to close,the motivation research promote a broad reorganization of findings, motivation as an umbrella term that encompasses both the purpose and reasons underlying decision processes and goal selection.

According to M.ZAKERI*(1997), this article mainly review science through conclude basic principles of motivation, described OBHP review progress by organizing theory and research around four principal questions that have long-driven scientific efforts in motivational psychology; finally discuss the representation theory and research for the journal. Modern views typically portray motivation as a time-linked set of recursive and reciprocal affective, behavioral, and cognitive processes and actions that are organized around an individual's goals. The result network structure of goals contributes to both the stability and heterogeneity observed in motivated action. Over the past half-century there have been numerous accounts of work motivation, the most prominent theories of work motivation address the proximal, internal individual psychological forces, mechanisms, and processes that determine goal choice and action. About the describe of motivation may be traced back to early 20th century work on the identification of universal human motives and tendencies. Beginning in the 1950s riveted research attention on the "how" question, including for example the cognitive processes by which expectancy and outcomes are integrated, and how best to conceptualize and assess affect. By the mid-1960s, however, motivational theorists began to question basic tenets of expectancy-value models and their applicability for predicting performance on new, difficult, prolonged, or ill-defined career and task goals. During the 1970s, social-cognitive theories and theories of action regulation emerged that addressed the gap between an individual's goals and performance. As "what" approaches gained traction during the late 20th century, motivation and decision-making researchers focused on increasingly different topics and questions. Motivational scientists within the broader organizational behavior domain focused on the processes by which goal attributes and the individual's construal of the goal influenced planning and self-regulatory processes during goal pursuit and performance accomplishments.About the "why" question of motivation is typically studied from a person-centric perspective,more focuses on the needs,motives wants and likes of individuals.During the mid-20th century, Maslow theory solve the two questions about how to describe human's hard through organize the numerous motives and what bring different needs as the driving force for behavior.

According to the different time and various theory described when start to propose the concept of motivation and how to better establish motivation system as well as some critical theory ,which make me better know the history of motivation and have a critical analyse.

About motivation and performance in high education this article mainly described people don't have better performance until motivation mechanisms exist. Stefania Zlatea (2015) in this article talk about the manager of high education should achievement their management goal through the members. So the strategy of motivate students

is the representation improve the organization for high education manager. During the process of motivation, the needs, aspirations and interests of university is related with people attain their target and realize their objectives, but responsibilities and competencies attributed to them. Motivation is very important in education area, fully understand what the motivation and best way to achieve motivation. As a manager know the ways to motivate the employee is a basic skills and also apply to another area.

Motivation referred to the different aspects. The concept of motivation is abstract, but it's very useful and important with specific workplace. This article is about the factors of motivate employee, to be specific, take example as Iranian, collect the date through a structured questionnaire survey. The result showed employees have five important motivation factors including "fairness of pay", "incentive and financial rewards", "on-time payment", "good working facilities", and "safe". This factors sustain the drive for high construction productivity in Iran, M.ZAKERI*^p(1997).

According to Ramona Todericiua (2013), employee are the bracket in a company, the employee who have motivation can make the company have high efficiency and good relationship each other. At the same time, the best competitive advantages that one organization could have, since all the other resources could be imitated. Consequently, motivated employee are easy to make the organization success and keep pace with market force. This articles take Sibiu as example aim at find the motivation ways in which knowledge workers. Reviewing the correlative researchers articles and give some guidelines for identifying the complex problems in order to motivate precious resources and further research.

5 MOTIVATION THEORY

5.1 Maslow's Hierarchy of Needs

Maslow's hierarchy of needs is a theory in psychology proposed by Abraham Maslow in his 1943 paper "A Theory of Human Motivation" in Psychological Review. Maslow used the terms "physiological", "safety", "belonging" and "love", "esteem", "self-actualization", and "self-transcendence" to describe the pattern that human motivations generally move through. The goal of Maslow's Theory is to attain the sixth level of stage: self transcendent needs.

In my opinion, the development of Maslow's hierarchy of needs coincidence with majority of people needs, because the first needs for most of people is meet their physiological needs ,which is basic needs when people have nothing, they desire to have full food, water and sleeping, and then they have the basic ability of survive. The second one is safety, belong ,love esteem, for this factors, people will pursuit the higher needs when they have good quality of life. However, Maslow theory described the human's behavior's need as a whole, but different peo-

ple have their own different character, children are easy to tend tasty food ,different kind of water and like to sleep. Young adults had the highest self-actualization level, the esteem need was highest among the adolescent group, and old age have high levels security, because they are old and out of health. So it depends on different age's people. On the other hand, some one who are rich and knowledge , money is not important for them, because they have good family and give them high quality of life as well as best education, they no need to care their family and children with money to make them get satisfactory. When they work in a company, they still work hard and have high effectiveness compared with the one who want to meet their physiology needs to work. The most important reason is they want to achieve their value and get the approval of the company and then have a meaningful life. So not only depends on their age, but also depends on someone have good family environment, some children have good education, good life and good family background, so it's not important for them to make money for survive. They want to achieve belonging and love needs even higher. On the other hand, different economic level's people still have different needs, according to I mentioned, the one who are poor family ,they need to work hard and support family and children ,so what they want to pursuit the first one is physiological needs and then on by one.Milota Vetrakovaa(2015).

5.2 Intrinsic Theories: Intrinsic and Extrinsic Motivation

Intrinsic motivation is the self-desire to seek out new things and new challenges, to analyze one's capacity, to observe and gain knowledge .It is driven by an interest or enjoyment in the task itself, and exists within the individual rather than relying on external pressures or a desire for consideration. Intrinsic motivation is a natural motivation tendency and is a critical element in cognitive, social, and physical development.

Extrinsic motivation refers to the performance of an activity in order to attain a desired outcome and it is the opposite of intrinsic motivation. Extrinsic motivation comes from influences outside of the individual. In extrinsic motivation, the harder question to answer is where do people get the motivation to carry out and continue to push with the persistence. Usually extrinsic motivation is used to attain outcomes that a person wouldn't get from intrinsic motivation.

Intrinsic motivation pay more attention to intrinsic activities itself compared with extrinsic motivation. For example, students learning refers to the students' learning is to point to their learning activities, which make student get emotional satisfaction and result in the sense of success. Intrinsic motivation supply nature power to promote learning and development, which don't have external reward and pressure, Stefania Zlatea(2015). When individual want to do something because of individual evaluation in

a particular activity or love interest, and measure whether would like to do the activity. However, for extrinsic motivation, individual prefer to affected by reward or punishment. To be specific, when individual got reward, punishment, language encourage during your work and so on, and then they will have high motivation to do work. Common extrinsic motivations are rewarded for showing the desired behavior, and the threat of punishment following misbehavior, Duminica Delia (2013).

5.3 Push and Pull Motivation

Push motivations are those where people push themselves towards their goals or to achieve something, such as the desire for escape, rest and relaxation, prestige, health and fitness, adventure, and social interaction.

Pull motivation is the opposite of push. It is the type of motivation that is much stronger, some of the factors are those that emerge as a result of the attractiveness of destination as it is perceived by those with the propensity to travel. They include both tangible resources. Pull motivation can be seen as the desire to achieve a goal so badly that it seems the goal is pulling us toward it. That is why pull motivation is stronger than push motivation. It is easier to be drawn to something rather than to push yourself for something you desire, Meltem Caber*, Tahir Albayrak (2016).

In my opinion, I think pull motivation is more effective than push motivation. Pull motivation means some goals attractive individual to achieve it, and easy to have high motivation, because the factors of effect the motivation is not the extrinsic factors, so intrinsic factors have good effect.

5.4 Cognitive Theories

5.4.1 Goal-setting Theory

Goal-setting theory is based on the notion that individuals sometimes have a drive to reach a clearly defined end states. Often, this end state is a reward in itself. A goal efficiency is affected by three features proximity, difficulty and specificity.

For example, the most students have motivation to study hard means they want to achieve some targets in order to make themselves satisfactory. This goals must be specific, measurable attainable/achievable, relevant, and time-bound. An ideal goal should present a situation where the time between the initiation of behavior and the end state is close. During the every step in our life, our goal should be specific and measurable, which means this goal suitable each other at the same time, and don't have high standard, otherwise, the goal that we want to attain it is very difficult and will decrease our motivation.

5.4.2 Expectancy Motivation

Expectancy theory was proposed by Victor H. Vroom in 1964. Expectancy theory explains the behavior process in which and individual selects a behavior option over another, and why/how this decision is made in relation to their goal. There's also an equation for this theory which goes as follows: $M = E \times I \times V$. M (Motivation) is the amount an individual will be motivated by the condition or environ-

ment they placed themselves in. Which is based from the following hence the equation. E (Expectancy) is the person's perception that effort will result in performance. In other words, it's the person assessment of how well and what kind of effort will relate in better performance. I (Instrumentality) is the person's perception that performance will be rewarded or punished. V (Valence) is the perceived amount of the reward or punishment that will result from the performance, Kenneth E. Barron (2015)

To be specific, the one who have high goal, and achieve the goal rate is more higher, and higher motivation, higher enthusiasm. During the leader and management work, it's meaningful that encourage employee with expectancy theory.

6 CRITICAL ANALYSIS

Motivation have different opinion in different theory. The first theories considered that if you pay the people adequately, they will be motivated. Yet, the contemporary theories state that people do not work only for money, but also to be content with what they are doing.

In my opinion, different people have their different needs, some people work for money, another people work for value. So the first factor is depend on different social level. That means every one have their own economic level in modern society, the one who have good economic level no need to work for money, because they have enough money to survive and enjoy life, so higher needs like belonging, love, esteem, and self-actualization needs are the most want to achieve. However, the one who have poor economic level, the first considered is food, clothes. So motivate individual depend on different economic level people. So the ways of motivation also is different because of the economic level.

The second factor is about family background, some one have good background and no need to worried about the beautiful clothes, delicious food and basic needs, all of these already was supported by their family. The next step for their family is to give their children create a high quality and good environment to study as well as rightly instruct them have positive attitude. Consequently, these children who are growing in good family background have better chances to attain self-actualization needs and no need to motivate by money. On the contrary, children born to families of lower economic status, do not have abundant resources including education, surplus clothes and different kind of food as well as colorful life. This is normal phenomenon that they need to strive for the life, work for money and have enough food, clothes, and then to pursuit the higher needs such as belonging, love and esteem, maybe self-actualization is hard and short time to achieve it, because they need to try their best to attain basic satisfactory to life, and then consider themselves. In this situation, they are easy to motivate by money, this factor is important for them.

Another factor is about the level of education, the person with higher education level are easy to know what's their goal and make great efforts for it. Because they have basic cognitive for this society and also have more opportunity to choose life then have tangible resource such as good work chance, better individual performance as well as

open mind, they will try to adjust best attitude to embrace life. Further more, motivation attractive them to go ahead. On the other hand, the person with lower education easy to trap into the frustrate and lost the motivation, that means they don't have goal motivation and pull motivation to make them work hard. In all ,every people have their own needs, which have many factors effect the ways of motivation. So to some extent ,this is also decided by economic level , family environment and education level.

An article mentioned about motivation one understands an inner state determining an individual to behave in such a way as to attain a certain goal,Ramona Todericiua (2013). Regarding motivation in relation to work, it can be defined as the availability of an individual to work intensely and consistently in order to realize the organizational objectives, with the hope that the effort made will lead to the realization of some individual objectives. These individual objectives, generated, finally, by the needs that the individual feels, are veritable reasons determining him to act and work in organizations. The one who have motivation will have high passion to do their work, the motivation is eager to work and from their intrinsic needs.

7 FINDING

The concept of motivation is abstract, it's hard to better understand what is the motivation and how to promote the employee have higher motivation to work as well as what is systemic incentive which have complete approaches to make employee keep their passion during their work.

Different people have their different character in an organization. We should focus on specific approaches during the work. The article about Modeling of Process Work Motivation in Hotels, which described employees of chair hotels would like to see more attention paid to the promotion of education. For employees in independent hotels, they are more motivated by financial benefits.The difference is also in the employees themselves and their needs, as well as in understanding the culture of the hotel. In chair hotels are employees proud that may be part of the brand and contribute to the achievement of business objectives. Also because they want to further develop, whether through training or improving vocational education.

The first one is to find the different needs of employee according the interviewed the ASJ company this week in Malaysia. The manager said different level employee still have different motivation ways. For lower employee, most of them only need reward to meet them, when it comes to the end of a year, the manager will give them more than 12 months' salary in order to motivate them. So money is very important factors for lower employee, because they don't have high knowledge and capability to do management job, and current job that work in the factory is very simple. However, for top level employee, they will more pay attention to the job satisfactory, that means they work hard not only because of the salary ,but also the important is they want to achieve their value and make them feel satisfied. At the same time, they will give the employee fully relax time and opportunity to tell their issues during the eating time. And have meeting that explain to the managers in

order to better understand what the problem employee faced and to deal with the problem.

The most important factors that can't ignore is communication , which can motivate the employee. Communication is an aspect that is vital for managing people. This is the only way in which a manager could asses which type of motivation method he needs to use and also one of the main channels for supporting all the developed activities in this perspective.The creation of familiar ties between managers and workers is a fundamental aspect of HR management in every knowledge company. Informal communication, caring and constructive behaviors and professionalism are crucial, as they enable managers and scientists to learn about each other and their work, thus providing the foundation for collaboration.

When we know different people's character and what they want and motivate them have high effective, then our organization will have high performance. For example, the employee who feel motivated, and avoid raising the salary,try to boost motivation by offering free rewards,Such as praise from a manager, as more time off. And then will decrease the cost of motivation. On the other hand, If employees sense an interest on the part of the organization,Offering them training, demonstrating trust in them and an intention to count on them in the long-term, such as the culture; skills of work; structure. Make an motivation action for those suitable people and have a good effect for organization. In addition, there are five basic elements of reward are: payment, short time incentives, long time incentives, money benefits, no matter how much they are. The financial incentives' plan must be conceived, not only to reward the performance, but to minimalism the additional effects, like conflicts and claims. Before starting a payment plan to motivate performance: individual employee performances, the payment's amount for high performance, individual performance motivation methods, submission. For a supporting and an efficient motivation, reward should be a prompt and an immediate one. Reward could work as an accelerator for the batterer of the performance and the productivity batterer; but only that is not enough, and, anyway, it is not a substitute for a good management. It's rather a part of it.

Consequently, reward just is one part of management and not is the best one, we should pay attention to the best effectiveness ways of motivation and take measures to motivate the employee. According to the mentioned below, it's good for company's management system that find the ways fit different people's motivation needs.

8. CONCLUSION

Through this article review, I reviewed 6 articles at least, and the first one is know the history of motivation, and different motivation theory have different opinion about motivation. I have better understand to motivation through relevant articles study. Some articles are abstract and hard to measure the ways of motivation. But another articles take some places as example, so about the factor or ways about motivation easy to understand and I also have my own opinion to motivation.

Maslow Lower level---money is a motivator; however, it tends to have a motivating effect on employees that lasts

only for a short period. (a benefit that cannot be sustained on a long term is better not offered at all because otherwise it will decrease the moral of the employee.) At higher levels --- praise, respect, recognition, empowerment, and a sense of belonging are far more powerful motivators than money. However, McGregor placed money in Theory X category and considers it as a poor motivator. whereas praise and recognition are placed in the Theory Y category and are considered stronger motivators than money. Likewise, McClelland asserted that workers could not be motivated by the mere need for money and in fact, extrinsic motivation (money) could extinguish intrinsic motivation such as achievement motivation. Herzberg differentiated hygiene factors from motivators in the length of time the particular factor continues to drive behaviors. The salary has a short motivational time span.

We can draw a conclusion that money is the lower and basic needs for individual , the most important, last long time motivation is intrinsic motivation ,pull motivation,which have good effect for employee.The acknowledgement of the importance of a proper human resource management is imperative for any organization that aspire progress. While monetary rewards certainly have an important role to play, managers should consider the lessons of the crisis and think about the best alternative ways to engage and inspire employees. Managers need to recognize remarkable talent, set clear objectives and performance metrics for each employee, and provide incentives and rewards that match each individual's motivation. Because money only extrinsic reward and can't attain the reality purpose of motivation. A company should consider the core ways of motivation, if reward last long time ,employee will amplify their desire to attain more reward, but company have limited human resource cost, so motivation system should focus on every individual's needs and take action.

9 REFERENCES

- [1] Ruth Kanfer a, Gilad Chen.Motivation in organizational behavior: History, advances and prospect,136 (2016) 6–19
- [2] Stefania Zlatea, Gabriel Cucuib.Motivation and performance in higher education. Procedia - Social and Behavioral Sciences,180 (2015) 468 – 476
- [3] M. ZAKERI* P. OLOMOLAIYE* G. D. HOLT* F. C. HARRIS.Factors Affecting the Motivation of Iranian Construction Operatives. iualsfmg and Enironmenr, Vol. 32, No. 2, pp. 161-166, 1997 0 1997
- [4] Ramona Todericiua, Anca,Serban,Oana Dumitrascu. Particularities of Knowledge Worker's Motivation Strategies in Romanian Organizations. Procedia Economics and Finance 6 (2013) 405 – 413
- [5] Milota Vetrákováa, Ludmila Mazúchováb.Modeling of Process Work Motivation in Hotels, Procedia Economics and Finance 34 (2015) 508 – 513
- [6] Duminică Delia, Popescu Georgiana.Motivational dynamics in media organizations.Procedia - Social and Behavioral Sciences 76 (2013) 312 – 316
- [7] James C. Naylor & George E. Briggs Effects of task complexity and task organization on the relative efficiency of part and whole training methods.Journal of Experimental Psychology 65 (3):217 (1963)
- [8] Herzberg, F., One more time: how do you motivate employees? Harvard Business Review, 1968,46(1). 53-62.
- [9] Meltem Caber* , Tahir Albayrak.Push or pull? Identifying rock climbing tourists' motivations*.Tourism Management 55 (2016) 74e84
- [10] Buckley, R. (2007). Adventure tourism products: price, duration, size, skill, remoteness. Tourism Management, 28, 1428e1433
- [11] Csikszentmihalyi, M. (1990). Flow: The psychology of optimal experience. New York: Harper & Row. Dann, G. M. S. (1981). Tourist motivation: an appraisal. Annals of Tourism Research, 8, 187e219.
- [12] Kenneth E. Barron,Expectancy-Value-Cost Model of Motivation.2015, Pages 503–509

Auditing Standards and Auditors Performance: A Study of Nigerian Banks

Irene Falola^{*1}, Otokini Tams-Alasia², Uneke Udochukwu¹

¹Department of Accounting, Covenant University, Ota, Ogun State, Nigeria

²Department of Banking and Finance, Covenant University, Ota, Ogun State

*falolairene1995@yahoo.com

Abstract— The objective of this study is to examine the impact of auditing standards on auditor's performance in the Nigerian banking sector. The rate of fraud and unethical practices occurring in the Nigerian Banks are quite alarming. Fingers are pointed at the auditors with the notion that they are not performing their responsibilities with a high level of competence and compliance to the regulatory framework. To achieve the objectives of the research, three hypotheses were formulated using the structure of the research questions. The type of data used for the study is primary data through the issue of questionnaires to auditors of banks from big fours. The data obtained were analysed using ordinary least square regression model through SPSS. The findings show that auditing standards is important in enhancing the auditor's performance in the banking industry. It also indicates that accountability and auditor's performance are positively related. It also shows that auditing standards and compliance has an effect of auditor's performance. Compliance has a positive but weak degree of relationship with auditor's performance therefore implying that it does have that much influence on the auditor's performance. The study recommends that the financial reporting council should closely monitor the banking sector in order to enforce strict compliance to regulation and attach sanctions to violations.

Keyword— Auditor Performance, Accountability, Auditors Compliance, Auditors Competence

1 INTRODUCTION

Auditing can be traced to as far back as the inception of accounting (Ajao, Olamide & Temitope, 2016). This was as a result of the need to check the accounting reports and activities that have been reported to increase the reliability and assurance placed on the reports. Auditing is an integral part of the accounting sector which should be guided by standards to ensure that the body is effective and efficient (Fagbemi, Abogun, Uadiale & Uwuigbe, 2013). The essence of setting standards is to direct the behavior of the auditor towards achieving the aim and goals of the audit. The auditor's role is to add credibility and increase assurance; hence, it is important to establish standards to guide their behaviors. Standards have been put in place to regulate the profession some of which are International Standards on Auditing (ISA), Nigerian Standards on Auditing (NSA) and so on (Ajao et al, 2016).

The Nigerian banking sector can be seen as an accelerator for the nation's development. The banking sector is a large sector and engages in activities such as resource allocation, funds management, human capital mobilization, setting polies for monetary and macroeconomics purpose (Jibrin, Blessing, & Danjuma, 2014). Nigerian banks also offer a helping hand when the nation is facing challenges in developing by distributing resources to the various functional and productive areas of a nation and making sure that areas of deficit are being identified in order to enable its funding using the excess of areas with surplus funding.

This is as result of the different crisis that has occurred in the Banking sector which has caused banks to be acquired or merged as a result of the high level of fraud discovered. Some of these failure or crisis has been attributed to audit failure. This study aims to emphasize on the relevance of auditing standards on the auditor's performance. It intends to evaluate how some other factors like auditor's compliance, auditors competence and auditors accountability can also influence the auditors performance.

2 LITERATURE REVIEW

Public Sector Accounting defined Auditing as "the evaluation of the financial reports of an organization with the aim of providing a reasonable assurance that the presented reports shows the truthfulness and fairness of the financial position of the firm, the reports have been prepared in accordance with the necessary regulatory framework and that the internal control system of the organization has been scrutinized" (Ezeani & Rotimi, 2012). An audit is all about examining the financial reports with an independent mind and giving a professional opinion on the reports of the organization in compliance with the terms of engagement, professional and statutory requirements, (Ezugwu & Negedu, 2014). The independent examination of the financial reports as well as the expression of opinion is being carried out by an auditor who is appointed to pursue the appointment and recognizing the necessary obligations attached, (Ezeani & Rotimi, 2012).

Standard, in the days of old, was usually seen as a sign to align and converge allies during a battle as a form of regulating the battlefield (Ajao, Olamide, & Temitope, 2016). The Oxford Accounting dictionary has described the Auditing standards as “the fundamental building blocks in which auditors are to comply and conduct their audit of financial statements. In other words, the audit standards should be in accordance with the objectives of an audit (acceptability, relevance, consistency and suitability) and also has to be important and suitable within a particular social environment” (Ohiokha & Akhalumeh, 2013). Audit standards are guidelines to the measurement of various transactions and activities that will affect the financial outcome and accounting information being given to the diverse users involved (Fagbbemi, Segun, Uadiale, & Uwuigbe, 2013).

In Nigeria, prior to the industrial revolution that took place in the 1900, accounting was majorly concentrated in the government sector (Ajao, Olamide, & Temitope, 2016). The economic growth was high during this period thereby bringing about the existence of managers that were not owners of the business. This new dimension made it necessary for the owners to have individuals independent of management to help evaluate the reports made by these managers. The origination of the concepts, internal control and audit risk has taken much attention in the audit profession. Overtime, fraud detection is no longer the objective of audit; it is now focused on examining the managements report independently (as a professional) and giving their observations and finding to the shareholders (Okoye, Okaro, & Okafor, 2015).

In Nigeria, we have two professional accounting bodies that are self-regulatory: ICAN -- The Institute of Chartered Accountants of Nigerian and ANAN -- The Association of National Accountants of Nigeria (Ajao, Olamide, & Temitope, 2016). They have been statutorily been appointed for setting of standards and regulating of the accounting profession in Nigeria. ICAN members are to comply with the Nigerian Standards on Auditing (NSA) which is established in line with International Standards on Auditing. (ISA).The Nigerian standards on Auditing (NSA) have a total number of thirty six (36) standards as issued by the Institute of Chartered Accountants of Nigeria (ICAN) to guide auditors conduct.

2.1 Theoretical Framework

2.1.1 Agency Theory

This theory propounds that when owner(s) hire agent(s) to help out in the decision making of the firm as well as other services, there exist and agency relationship (Hassan & Farouk, 2014, Jibrin, Blessing, & Danjuma, 2014; Ajao, Olamide, & Temitope, 2016). The theory focuses on the conflicts that exist as a result of this relationship and also takes into consideration corporate governance and ethical values. The theory is of the notion that agents are expected

to behave and act in the interest of the owner (Hassan & Farouk, 2014). In reality, the agents usually act in their own self-interest. This has been as result of the misinterpretation of the corporate governance code thereby leading to bad practices in the Nigerian Banking sector (Jibrin, Blessing, & Danjuma, 2014). The audit fees are bond fee paid by the principal/owners to an independent individual to review and check the activities of the agent/management and boost the level of assurance and confidence on financial information (Hassan & Farouk, 2014).

2.2 Development of Hypotheses

The hypotheses for the study are stated in their null form.

- H₁ There is a degree relationship between auditing standards and auditor’s performance.
- H₂ There is no level of relationship between accountability and auditors performance.
- H₃ The auditor’s competence and compliance do not depend on the adherence to auditing standards.

3 MATERIALS AND METHODS

In the conduct of this research, descriptive survey method has been employed. This is used because the study will make use of convenience sampling of the population and draw findings based on this conclusion upon the analysis of available data. The survey method is used as a result of the researchers’ inability to manipulate the variables employed in this research. This research made use of a population size of auditors for both bank. Absolute attention was given to selecting a sample size in order to ensure a valid representation of the population. Confidentiality of information were the constraints encountered in carrying out this research. The sampling method employed in deriving the samples was non random sampling method (convenience sampling method). Questionnaires were issued to target population of (100) auditors with sixty (60) respondents.

3.1 Model specification:

The econometric model used to explain the relationship between the dependent and independent variables was adopted from the work of

$$AUP = f \{ACT, AUS, ACP, ACL\};$$

$$AUP = \beta_0 + \beta_1AS + \beta_2ACP + \beta_3ACI$$

Where:

- AUP= Auditors performance
- ACT= Accountability
- AUS= Auditing standards
- ACL= Auditors Compliance
- ACP= Auditors Competence

The two categories of variables (dependent and independent variables) have been used as focus points in the questionnaire issued which relates to auditor’s performance,

accountability, auditing standards, auditors compliance and auditors competence in the regulation of the audit profession. In order to measure the degree of significance of relationships that exist between independent and dependent relationship, a five-point scale technique was used. The five-point likert scale is 1 = strongly disagreed, 2 = Disagreed, 3 = Undecided, 4 = Agreed, 5 = Strongly Agreed, this order of ranking was employed in the analysis of data. The data collected was analyzed using Pearson correlation analysis.

4 DISCUSSION OF RESULTS

The result of the research performed is stated in the table below;

Table 1: Ordinary least square results

60 observations for estimation for 1-60

Independent Variables	Co-efficient	Standard error	t-value	Public
CONSTANT	16.4131	6.9137	1.3859	0.22
ACT	0.18242	0.18761	0.65044	0.469
AUS	0.19403	0.13977	1.4001	0.176
ACL	-0.8768954	0.19857	-0.48569	0.604
ACP	-0.0102437	0.17377	-0.685686	0.593

Source: SPSS Result
 R2= square 0.068530
 Adjusted R- square = 0.0027850
 S.E of Regression = 6.1477
 F- Statistic =1.0323
 Mean of dependent variable = 22.4098
 SD of dependent variable = 6.1657
 Durbin –Watson statistics (DW) =1.8565
 $AUP = 16.4131 + 0.18242 ACT + 0.19403 AUS - 0.87690 ACL - 0.01024 ACP + U$

4.1 Test of Hypotheses and Regression Results

The analysis of the OLS result from the above table shows that the co-efficient of determination (R Square) was at 0.068 which indicates that roughly 6% of the variations in the auditor’s performance level is explained by the differences in the explanatory variables in the model. This result shows a low goodness of fit implying that a larger part of variations is caused by other variables not mentioned as represented by the error term. The F statistics of 1.03 is less than the critical F value of 2.76 at significance level of 5%. This implies that the linear function stated above might not apply to this case.

The analysis of the coefficient variables reveals the following;

ACT: is positive; thereby implying that accountability are aligned with auditing standards. The effect is statistically insignificant at 5%. In other words, audit performance is not solely dependent on accountability. However,

the adherence to these standards and regulations in order to be compliant will be important to improve accountability.

AUS: is positive; this implies that auditing standards provide the necessary context that will guide auditor’s performance. In other words, there are other variables aside from auditing standards that contribute to audit performance. However, the adherence to these standards and regulations in order to be compliant will be important to improve audit performance.

ACL: is negative; that is, the effect audit standard on compliance is negative at 5% level of significance. This implies that standards may not lead to improved audit performance

ACP is negative; this implies that the competence of the auditor is not dependent on audit standards.

Table 2: Correlation Result

	AUP	ACT	AUS	ACL	ACP
AUP	1	0.169	0.229	0.519	0.065
ACS	0.169	1	0.379	0.546	0.156
AUS	0.229	0.379	1	0.095	0.165
ACL	0.519	0.546	0.095	1	0.167
ACP	0.065	0.156	0.167	0.123	1

Source: Field work 2016

Where:

- AUP = Auditors Performance
- ACT = Accountability
- AUS = Auditing Standards
- ACL = Auditors compliance
- ACP = Auditors competence

The above correlation result shows that the independent variables (auditing standards and accountability) have a positive relationship with dependent variable (auditors’ performance). The relationship between auditors performance and auditing standards shows 0.196 which suggests that there is a positive correlation coefficient but weak association between the two variables. The relationship between compliance and auditors performance are positively correlated at 0.519 indicating that auditing standards increased adherence will improve auditors performance. Performance and competence have a positive but weak relationship with a correlation coefficient of 0.065.

4.2 DISCUSSION OF RESULTS

The analysis of data using Pearson correlation method of analysis showed the level of relationship between the dependent variable (auditors’ performance) and the independent variables (auditing standards, accountability, competence and compliance).The analysis of data showed that the degree of relationship between auditing standards

and the auditor's performance shows a 0.904 correlation coefficient. This suggests that there is a positive correlation coefficient and strong association between the two variables. This implies auditing standards provide the necessary context that will guide auditor's performance. In other words, there are other variables aside from auditing standards that contribute to audit performance. However, the adherence to these standards and regulations in order to be compliant will be important to improve audit performance. The relationship between auditors compliance and auditors performance shows a 0.786 correlation coefficient. This suggests that there is a positive correlation coefficient and strong association between the two variables. This indicates that auditing standards increased adherence will improve auditor's performance. This implies that if auditors comply with the relevant auditing standards, their performance will be enhanced. It also implies that these standards are being complied with. The relationship between the auditor's performance and accountability shows a 0.07 correlation coefficient. This suggests that there is a positive but weak relationship between the two variables. This means that there is a relationship between accountability and auditor's performance but audit performance is not solely dependent on accountability. The analysis of auditor's competence on auditor's performance shows -.177 correlation coefficient. This implies that the competence of the auditor is not dependent on audit standards.

4.3 FINDINGS

The results of the analysis of data above show that auditing standards is important in enhancing the auditor's performance in the banking industry. It also indicates that accountability and auditor's performance are positively related which implies that when auditors comply with auditing standards, their performance will be enhanced. It has also discovered that accountability is very important in auditor's performance. It also implies that auditing standards provide the essential framework that will be adhered to by auditors thereby enhancing their performance. Proper regulations will have to be put in place in order to attain a very significant improvement on the auditor's performance. Compliance has a positive but weak degree of relationship with auditor's performance therefore implying that it does have that much influence on the auditor's performance. However, the implication of this finding is that the compliance of auditors according to stipulated findings is capable of improving their performance. Competence has a negative relationship and is insignificant to auditors' performance.

5 CONCLUSION AND RECOMMENDATION

This study was focused on the evaluation of auditing standards on auditor's performance in the banking sector.

The Financial Reporting Council should endeavor to closely monitor the banking sector in order to enforce compliance especially among those that are performing below standard. Noncompliance should be sanctioned through fine, levies or withdrawal of operating licenses for both the industry participants as well as the auditors. The NSA issued by ICAN should be reviewed as they are not completely aligned with ISA. The finding of this work has indicated that auditing standard set rule and guidelines which has the auditors to perform the audit in such a way that gives his work a high degree of assurance. The research also recommends that the ISA and NSA need more interpretation in order to ensure that the main aim and objective, through the compliance of the auditor, is achieved. Auditors should be educated on the need for compliance and its effect on their performance. It can therefore be said that auditing standards has a significant relationship with auditors' performance.

REFERENCES

- [1] Ajao, O. S., Olamide, J. O., & Temitope, A. A. (2016). Evolution and development of auditing. *Unique Journal of Business Management Research*, 32-40.
- [2] Ezeani, N. S., & Rotimi, O. (2012). Auditing as a Tool for Accountability for Efficient and Effective school Administration. *Arabian Journal of Business and Management Review*, 49-54.
- [3] Ezugwu, C. I., & Negedu, E. (2014). Auditors Reputation: The Impact on Compliance with International Accounting Standard 5 by Quoted Companies. *Kuwait Chapter of Arabian Journal of Business and Management Review*, 28-37.
- [4] Fagbemi, T. O., Segun, A., Uadiale, O. M., & Uwuigbe, O. (2013). An Assessment of Audit Approach and Audit Quality in Nigeria. *Research Journal of Finance and Accounting*, 10-19.
- [5] Hassan, S. U., & Farouk, M. A. (2014). Audit Quality and Financial Performance of Quoted Cement Firms in Nigeria. *European Journal of Business and Management*, 73-82.
- [6] Jibrin, M., Blessing, S., & Danjuma, I. (2014). The Role of Auditors in the Recent Nigerian Banking Crisis. *Int. Journ. of Acad. Research in Bus. & Soc. Sciences*, 232-251.
- [7] Ohiokha, F. I., & Akhalumeh, J. B. (2013). Auditing Standards and Auditors Performance: The Nigerian Experience. *European Centre for Research Training and Development UK*, 16-22.
- [8] Okoye, E., Okaro, S. C., & Okafor, G. O. (2015). Fighting the Scourge of Audit Failures in Nigeria- the Search for Audit Quality. *Int. Journal of Academic Research in Business and Social Sciences Search for Audit Quality*, 105-114.
- [9] Yahaya, k. A., Abdulraheem, A., Salman, R. T., & Etudaiye-Murhtar, O. F. (2012). Relationship between Level of Compliance with Statement of Accounting Standards and Performance of Nigerian Banks. *International Journal of Business and Management*, 128-136.

The Dynamics of Governance and Accountability in Nigerian Public Service: A Backward Look for a Diagnostic Cure

John Sani^{*}, G.O. Alani

Department of Accountancy Federal Polytechnic, Idah, Kogi State

[*talk2johnsani@gmail.com](mailto:talk2johnsani@gmail.com)

Abstract—This paper examines the dynamics of governance and accountability in Nigeria public service. The study employs secondary data from 1962 to 2017, and employs ex-post facto research approach. The paper berates the woes that trail the country as a result of lack of proper governance practice and lack of accountability as political office holders dealt with the public funds for personal gains. The paper recommends attitudinal reorientation, public declaration of assets, speedier adjudication process and the removal of the obnoxious immunity clause in the constitution.

Keyword— Accountability; adjudication; Governance; Whistler

1. INTRODUCTION

NIGERIA since independence in 1960 had passed through military and democratic regimes. The coups and transitions in government that had taken place had had both positive and negative impact on Nigeria. Nigeria is a land of abundant resource namely: manpower, material etc. But the most unfortunate thing is that though these resources abound, the management of these resources for national progress has been the problem.

Nnonyelu [1], opined that Nigeria is the most populous country in Africa and has vast arable land that made her in early 60s the largest producer of palm oil, groundnut and cocoa. Eventually the 'sleeping giant' of Africa snowballed to a country whose citizens continue to wallow in poverty, unemployment and other social vices. This situation has led Ndibe [2] to ask "how does one explain a country which has one of the world's vastest reserves of crude oil and gas, but whose citizens continue to wallow in levels of squalor and privation? How in other words do you analyze a people who take such ludicrous delight in their impoverishment that the citizens have inadvertently created the fertile ground for the pervasive lack of accountability and probity in our national life? The massive stealing of our national patrimony has continued for a greater part in the nation's post independence history. And Nigerians are not holding our leaders accountable, that the country has become a large gangland where thievery of societal wealth has become the norm, where public and private citizens have all been corrupted by the infectious bug of corruption.

How do we explain this? How does one explain the rape and plunder; mindboggling looting of the national treasury? How can one explain for instance, that an agency of government, Nigerian ports authority (NPA) is alleged to have collected 150 billion naira as revenue, only to pay in 2 billion naira into the Federation account? How can one explain the absence and total breakdown of infrastructure, the near bankruptcy of the country? How does one explain that several state governments were owing

their workers arrears of salaries? How do we explain the sudden wealth syndrome where charlatans and nondescript characters become billionaires overnight? Why has public office become the easiest and surest route to becoming wealthy? Why do Nigerians regard some ministries, committees, agencies as plum or juicy? How does one explain the social mis-governance or none governance as is often the case? How did we get to the stage where unbridled criminality, kidnapping, armed robbery, insurgency and terrorism, pen robbery now hold the nation hostage?

The study adopts ex-post facto research approach which is a systematic empirical inquiry because their manifestations had already occurred. The study looked at the performance of the political office holders from 1962, to the present dispensation. The following questions are necessary in the study. To what extent has the political office holders misgovern the country and displayed lack of accountability? What had been the efforts of frauds fighting organs in checkmating poor governance and lack of accountability? How would one assess the pre-2015 political office holders' misgovernance and lack of accountability to that of post 2015 era? Although there are other areas of accountability, the investigators would want to confine themselves to financial accountability. The study is intended to achieve the following objectives namely: to identify public officials that are entrusted with public funds and the extent of abuse of such trust; to assess the extent of recovery of looted treasury after 2015 political era.

2 CONCEPTUAL CLARIFICATIONS

2.1 Governance

The World Bank [3] defines governance as the manner in which power is exercised in the management of a country's economic and social resources for development. Landellmill and Seregeldin [4] comprehensively defined it as the use of political authority and exercise of control over a

society and the management of its resources for social and economic development. When a government is disciplined, transparent and honest, it sends positive signals not only to the citizens, but also to the international community. Good governance promotes rapid socio-economic development, while bad governance inhibits or drains away the accumulation. Scholars generally agree that the lack of transparency, accountability and good governance had been the fundamental impediments to the rapid socio-economic and political development of the nation state.

Odey (2000) as cited by Oni [5] presented a pathetic scenario when he lamented that: the countless billions that providence poured into our national coffers in the last ten years (1972-1982) would have been enough to launch this nation into the middle rank of developed nations and transformed the lives of her poor and needy. But what have we done with it? Stolen and salted away by people and their accomplices. Squandered in uncontrolled importation of all kinds of useless consumer merchandise from every corner of the globe. Embezzled through inflated contracts of an increasing army of party loyalists who have neither the desires nor the competence to execute such contracts.

2.2 Accountability

Accountability refers to the requirement that the government or even government functionaries or ruler explain and justify its actions to the people (they ruled). Adakai [6], opined it means answerability for ones stewardship. Ibrahim [7] defines accountability as responsibility or answerability. To be accountable is to be answerable or responsible for the resources put under one's control and for the authority one is vested with [8]. Accountability's functions are to guide against abuse of power; to ensure that resource of organizations are used wisely and in accordance with the law/procedure and to encourage and promote learning in pursuit of continuous improvement in governance. Accountability breeds improvement in performance and learning. Accountability is taken to be the solution to the challenges of governance. Accountability involves record keeping, reporting, auditing and oversight functions which are necessary in the public organizations. In a nutshell, accountability in organizations is to make the stakeholders aware of whether the resources entrusted into the hands of public agents are properly handled and that government services, programmes, and organizations function well economically, efficiently and effectively.

2.3 Types of Accountability

The characteristics of accountability prompt researchers to approach this important concept from their own subject area (paradigm). There is manifold accountability to stakeholders in the public sector.

- a. Political Accountability: This is where public managers, head of agencies and Ministers are called upon to give account in the case of parliamentary inquiries [9].
- b. Legal Accountability: Heads of parastatal and agencies can be called upon by courts to come and give accounts of their conducts on behalf of their agencies. Legal accountability "based on the specific responsibilities formally or legally con-

ferred on authorities [10].

- c. Administrative Accountability: This accountability forum can only make recommendations for solutions to the problems they have seen but cannot enforce their recommended solutions. This is legal and quasi-legal forum which exercises independent, external administrative and financial oversight and control over the public manager [11].
- d. Society Accountability: Government is being held to account by various interest groups: citizens, social groups, trade unions, labour unions, NGOs, civil society, aid donors, human rights activists and opposition parties. They criticize government policies, decisions and actions for the general good of the society. They engage in a critical dialogue with the government, organize protest actions ranging from peaceful demonstration to destruction of government properties or strikes to press home their demands. Their target is to put pressure on the government to influence their political policies [12].
- e. Professional Accountability: Most of the heads of private/public sectors are also members of professional bodies- like engineers, accountants, doctors, teachers, nurses and so on. These professions have codes and ethics which guide the conduct of members. These codes and ethics are monitored and enforced on members. Any members who behave unethically will have his certificate withdrawn [11].
- f. Organizational accountability: This procedure operates in the organization where the juniors are to give accounts of their assignments to their superiors in a hierarchical order up to the chief executive. This is internal in nature [11].

2.4 Institutions/Legislations That Strengthen Good Governance

Nigerian economy is public sector driven. The public have been frustrated for weak governance and lack of accountability. The institutions/legislation that can hold public office holders accountable are:

- a. The National Assembly
- b. The Public Accounts Committee
- c. The Judiciary
- d. The Audit Ordinance (No. 28) Act of 1956 as amended
- e. Finance (Control and Management) Act of 1958 as amended
- f. Independent Corrupt Practices and other Related Offences Commission (ICPC) Act of 2000
- g. Economic and Financial Crimes Commissions (EFCC) Act 2004
- h. Professional Bodies
- i. Code of Conduct Bureau
- j. Budget Monitoring and Price Intelligence Unit (BMPIU)
- k. African Review Mechanism.

3. INSTANCES OF POOR GOVERNANCE PRACTICES AND LACK OF ACCOUNTABILITY

Cases of poor governance practices and lack of accountability reported (Daily Trust March 19th, 2016) include the following:

- a. Peter Odile- alleged to have diverted over N100 billion of the Rivers state funds. He was granted perpetual injunction restraining EFCC from probing the affairs of Rivers state in 2007 opining that the Probe would be prejudicial to the smooth running of the state.
- b. Adamu Muazu- alleged mismanaged N19.8 billion of Bauchi state money between 1999 and 2007. He was Governor of Bauchi State. His case has not been concluded as EFCC affirmed that Muazu has case to answer.
- c. Joshua Dariye-alleged to siphoned about N1.2 billion of the Plateau state's ecological fund and another N204 million meant for the state treasury. He is currently facing trial. He was the Governor of Plateau State.
- d. Saminu Turaki- alleged to have misappropriated N36 billion. He was the governor of Jigawa state from 1999 to 2007. He was declared wanted after continuous absence from court in 2014, November 13, he was still absent despite subsisting warrant of arrest.
- e. Stella Oduah- she was the Aviation Minister in former president Goodluck Jonathan. Prosecuted by EFCC over two now infamous armored BMW cars allegedly purchased for N255 million by the Nigerian Civil Aviation Authority. She obtained an interim injunction stopping the EFCC from prosecuting her on the matter. Justice Mohammed Yunusa of the Federal High Court, Lagos granted that the Independent Corrupt Practices and Other Related Offences Commission (ICPC), the Attorney- General of the Federation and the Inspector-General of Police from prosecuting her.
- f. Adebayo Alao-Akala - alleged that a contract of N 11.5 billion fraud without budgetary provision and obtaining it falsely, was awarded with the intent of enriching himself and two others. Questioned the jurisdiction of the Court opining that it was abuse of power to put anybody on trial for an offence not proven in Court.
- g. Ayo Fayose- alleged mismanaged N1.2 billion Poultry project when he was governor between 2003 and 2006. On November 22, 2012, he was re-arraigned on 27 count amended charge of over N416 million scam. At a point he wanted the charges quashed through a Court order that the offences were committed in Ekiti and not Lagos, Presently the trial was suspended because of an immunity clause because he was elected Governor in 2014.
- h. Orji Uzor Kalu- alleged diverted Abia state fund to the tune of N5.6 billion while in office in 2007. The Appeal Court ruled that he submit himself for trial.
- i. Boni Haruna- A former of Adamawa state was al-

leged and charged on a – 28 count charge of fraud and embezzlement to the tune of N10 million and another N16.1 million. The matter dragged until January 31, 2012 for ruling. The ruling was not ready and the matter was adjourned sine-die.

- j. Gbenga Daniel - A former governor of Ogun state- alleged mismanaged the state funds to the tune of N211.3 million between 2003 and 2011. The case had dragged so long though at a stage of prosecution.

More bogging news of lack of accountability and poor governance practices still thrive. Some reported in the Nation news paper Tuesday sept 1, 2015 P3 are:

- a. 2.2 billion dollar arms scandal
- b. A 6.9-million-dollar fraud committed under the guise of buying 3 mobile stages.
- c. A 2.5 billion-naira scam involving the renting of house boasts.
- d. 3.8 trillion naira out of the 8.1 trillion earned from crude oil (2012-2015) withheld by NNPC,
- e. 2.1 billion dollars from excess crude oil unaccounted for.
- f. 109.7 billion-naira royalty from oil firms unremitted by the Department of Petroleum Resources (DPR).
- g. 6 billion dollars allegedly stolen by some ministers between 2009 and 2012
- h. 13.9 billion dollars being proceeds of 160 million barrels of crude oil lost between 2009 and 2012.
- i. 16 million dollars from botched arms deal yet to be returned to Nigeria.
- j. 13 billion dollars Nigeria Liquefied Natural Gas (NLNG) dividends mostly unaccounted for.
- k. 30 billion-naira questionable waiver granted to rice importers
- l. 183 billion unaccounted for at the Niger Delta Development Commission.

4 THE STRIDES OF PRESIDENT BUHARI MOHAMMADU

History had it that poor governance practice had been investigated in the past. According to the views of Egwu [11], Probes and Commissions of Enquiry never led to the punishment of culprits and Achebe [13] opined that democratically elected government preached due process and did everything in contravention of due process. Records had it that from the Coker Commission of Enquiry in 1962 in the Eastern and the Western Nigeria to the Joda commission of Enquiry in the North in 1967, and the Asset Investigation Panel of 1975-1976; and the probes into FESTAC '77 Leyland buses and the cement importation scandals were merely executed to divert public attention elsewhere. Is history been repeated by the current recovery of loots of the treasury? A close look shows the contrary. Odunsi [14] opined that EFCC recovered over N473 billion in 2017. Another feat was made also between May 2015 and May 2016 according to Ogundipe [15] that N204,888,835,727.25, \$9,275,363,504.76, £5,992,803.01 and €314,649.17 were cash recoveries and recoveries under interim forfeiture (www.premiumtimes.com/newsheadlines)

20467). It follows then, that when the machineries of governance are properly set, accountability naturally follows.

CONCLUSION AND RECOMMENDATIONS

One cannot doubt that the infrastructural decay, the erosion scourge in the South and the desert encroachment in the North with the myriad of social vices are signals of the poor governance and lack of accountability. The proper functioning of governance and accountability will ensure economic growth. The paper therefore makes recommendations as follows:

- i. Attitudinal reorientation on the part of bureaucrats and the enforcement of internal control mechanism that guarantees effective functioning of governance and accountability process.
- ii. Nigerians entrusted with governance declare their assets publicly.
- iii. The civil society and the press must vigorously be involved in the fight.
- iv. Speedier adjudication process and stiffer punishment to officials that abuse proper governance and accountability tenets.
- v. The whistler must blow louder to send shivering sensation on potential corrupt Nigerians and recover whatsoever had been hidden anywhere.
- vi. Complete implementation of the cashless economy policy to discourage people from stacking ill gotten wealth in 'Ghana must go' bags in their houses.
- vii. The removal of the obnoxious immunity clause in the constitution.

REFERENCES

- [1] A. U. Nonyelu, "Creating Value Through Governance: Implementing a new Accountability Framework," *Conference of Certified National Accountants*, Abuja 26th – 29th October, 2015.
- [2] O. Ndibe, "The Aches and Pains of Explaining Nigeria," *Daily Sun*, P48, Tuesday August 25th, 2015.
- [3] World Bank, "Governance and Development," *Washington DC*, 1992.
- [4] P. Landell-Mills, Serayeld "Governance and External Factor," *Washington DC*, 1991.
- [5] K. J. Oni, "Promoting Transparency, Accountability and Good Governance in Nigeria in Education, Good Governance and Challenges of Nationhood in Nigeria, Lagos:" *Smartrade*, 2009.
- [6] F. Adakai, "Towards Effective Financial Accountability in the Local," 1993.
- [7] I. Ibrahim, "Accountability, Policy-Making in the Local Government," *Local Government Policy Making Execution in Nigeria*, N.O Isaac, O.Y Nuhu, (eds). Ibadan: Sam Bookman Publishers, 1998.
- [8] J. B. Kingsley, L. E. Howard, "Public Administration; Balancing Power and Accountability". *Illinois: More Publishing Co. Inc.*, 1979.
- [9] P. Barberis, "The New Public Management And A New Accountability," *Public Administration*, No. 76, Pp451-470, 1998. doi:10.1111/1467-9299.00111
- [10] M. Bovens, "Analyzing and Assessing Accounting: A conceptual Framework," *European Law Journal*, Vol. 13, No. 4, pp447-468, 2010.
- [11] J. O. J. Obera, "Professional ethics and social responsibility, glazed with governance,, accountability and transparency". Lokoja: Jimsy colour prints. 2016.
- [12] A. Yunusa, P. Abuh. "Corruption and accountability in the nigerian public sector: an empirical discourse," *International Journal of Public Administration and Management Research*, Vol. 3, No. 3, Pp47-54, 2016.
- [13] Egwu, E.U. "The Psycho-Dynamics of Corruption in Nigeria," *Contemporary Issues in social science*, J. O. C Ozioko, J. I. Onuha, (eds) Nsukka: Topmost Publishers. Pp126-147, 2001.

Influence of Recreational Activities on the Wellness and Level of Participation among Middle Class Income Earners in Osogbo

Olukemi O. Osadare and Clement B. Omiwale

Department of Hospitality, Leisure and Tourism Management, Federal Polytechnic, Ede, Osun State
akinwumi07@gmail.com

Abstract - This research work examined the influence of recreational activities on the wellness and level of participation among the middle class income in Osogbo. Various research techniques were implemented in collecting data for this research work which include field survey, site observation, personal communications, survey questionnaire and collection of secondary data. Five recreation centers were purposely selected from Osogbo, Osun state, using simple random technique. A total of fifty (50) respondents were sampled and questionnaire was used to elicit information from them. Data collected was presented using tables and graphs, and described using frequently counts and percentages. The findings showed that middle class income in Osogbo metropolis participates actively in recreational activities, although mostly on weekly basis. The participants expressed their preference for mental benefits as the highest perceived benefits from engaging in recreational activities, this is because it reduces stress and depression associated with today's working environment. This study thus recommends that government should put in place policies that will favors private investors in recreational business. The employers should ensure flexible working condition, so workers can enjoy their leisure. However, the employees should avoid overworking themselves, and spend leisure time for recreation activities only in order to enjoy the full benefits associated with it.

Keywords: Level of Participation, Mental Health Benefits; Middle Class Income; Recreational Activities; Wellness

1 INTRODUCTION

Every individual at some stage in their lives will participate in some recreational activities, be it active or passive recreation. Participation must be by choice in order to be considered recreation. Recreation is like experience that results from freely chosen participation in physical, social, intellectual and community well being.

Louis London (2011), in his blog, stated that average individual is recommended to divide his day into three: 8 hours of work, 8 hours of recreation and 8 hours of sleep in order to reach better balancing in life, get energy to work and be able to concentrate better.

The individual that engages in recreational activities and sleep well makes better decision during working hours (Louis, 2011, cited in Osadare, 2017).

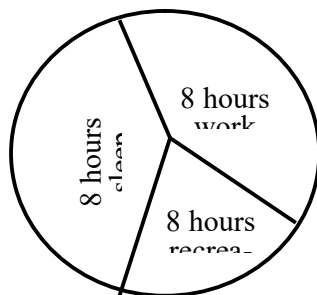

Figure 1: Ideal Average Day Management

1.1 Definitions of Recreation from the Literature

Recreation is considered as activities through which leisure may be experienced and enjoyed, but it is also seen as a social institution, sociality organized for social purposes (Grant and Allan, 1990).

George (1986), viewed recreation as personal experience (what it does to a person), as activities (the form it takes) or as an institution (the structure in which it is made available to the community). Taken yet another way, recreation can be viewed as a process (what happens to an individual) and as a structure (the framework in which recreation is practice).

John in his own definition considered recreation to be an activity voluntarily undertaken, primarily for pleasure and satisfaction, during leisure time (John, 1983).

Leisure is a block of unoccupied time, spare time or free time, when we are free to do as we choose. It is discretionary time when our feeling of compulsion should be minimal (Veal, 1992).

1.2 Leisure and Recreation

Leisure and recreation are not synonymous. Leisure is time element, one's free time, while recreation refers to activities in which one engages during leisure. Without leisure, recreation may not be feasible as leisure provides time element for recreational activities (Osadare and Adeyemi, 2017).

1.3 Elements of Tourism

- Recreation activities are engaged during leisure that is one's free time
- Recreation is concerned with activities human beings find pleasurable and satisfying, the reward is immediate satisfaction, no monetary reward.
- Recreation is voluntary, no coercion by someone else or forceful participation.
- Recreation is not anti-social, any activity that is not socially acceptable is not recreation. Such act as gambling, wrestling to kill and so on are not regarded as recreation.

1.4 Forms of Recreation

- **Active Recreation:** involves using a lot of energy and allow you to move around a lot. One is subject of the activity. Examples of active recreation are: Hiking, Jogging, Aerobics, Sport, and water based activities.
- **Passive Recreation:** this involves little exertion, but it is generally sustained. Examples of passive recreation are reading, fishing, listening to music, watching T.V.

1.5 Statement of Problem and Objectives

Pressure at work place is unavoidable due to the demands of the contemporary work environment. Increasing demands on the individual in the workplace reach out into homes and social lives of employees. Long, uncertain or unsocial hours, high level of responsibility, taking work home, job insecurity and lots more may affect level of participation in recreational activities of working class individuals. Lack of recreation is likely to undermine a good and relaxing quality of life outside work. Thus, this research work will examine the level of participation in recreational activities by middle class in Osogbo metropolis and benefits of active recreation to total wellness.

1.6 Justification

The Influence of recreational activities on human wellness cannot be over emphasized. Participating in recreational activities helps manage stress, taking time to nurture oneself provides a sense of balance and self-esteem. Oladeji and Adedapo, (2014) affirmed that both anxiety and extensive stress are as a result of overwork and they have been identified as indications of depression. They further explained that depression disrupts relationship and interferes with work and daily activities and must be avoided. Critcher, Bramham & Jomlinson, (2001) recalled that the result of increased leisure that is not properly utilized can manifest in various societal problems, ranging from illness, depression, violence, drug abuse and other related uses.

2.0 BENEFITS OF RECREATION

Recreation is as old as man and everybody needs it. It plays important role in physical, economic and socio-cultural development of mankind (Okoli, 2001).

In Nigeria however, it has been observed that culture of participating in recreation activities consciously is relatively low. This may not be unconnected with economic circumstance prevalent in the country.

2.1 The Physical Health Benefits

Recreational parks, trails and historical sites are excellent inducements to physical activity. These varied recreational opportunities make physical activity interesting, enjoyable and encourage life-long fitness habits.

- **It reduces obesity:** exercising activities can help curb obesity. Obesity is associated with increased risk for disease, mortality, chronic medical conditions.
- **Recreational activities diminishes risk of chronic disease** like diabetes, cancer, heart disease e.t.c. The correlation between recreation activity and health was highlighted naturally in a report from health and human services (HHS, 2001). Regular moderate activity like brisk walking for 30min to 60mins reduces the incidence of cardiovascular disease (Hannel and Lemore, 2002). People who exercise have a lower incidence of colon cancer than their sedentary counterpart (Lee, 1995).
- **It boosts immune system:** physically fit person is less prone to illness. Researches show that positive changes in the immune system occurs during moderate exercise (Nieman, 2001). Participating regularly in recreation activities help maintain bone and joint health (Gorman, 2002).
- **It increases life expectancy:** Regular physical activity reduces the risk of developing or dying from some of the leading causes of illness and death in the united state. On the average, every hour you spend exercising increases your life expectancy by two hours (ARC, 2000).

2.2 The Mental Health Benefits

Mental health disorders pose a significant public health burden and are a major cause of hospitalization disability.

- **It Reduces Depression:** recreation and leisure activities can help alleviate depression. Recreation also reduces alienation, loneliness and isolation. The more time participants spent on hobby, swing, visiting with friends, the more their depression decreased (Siegenthaler, 1997).
- **It relieves Stress:** the human body has built-in stress relievers that can be triggered through recreation activity. Revitalization through recreation

activity is essential to managing stress in today's busy and demanding world.

- **It improves the quality of life:** recreational activities helps in changing self-image, self esteem, personal and spiritual growth and life satisfaction. Consistent recreation activity increase self esteem, according to a substantial number of studies (Frank and Gustafson, 2001).

2.3 The Social Benefits

Recreational opportunities can have positive impacts on our society. Survey opinions and crime statistics support of link between open spaces recreation and reduced crime (SCRA, 2005)

- **It strengthens communities:** park and recreation opportunities are essential for strengthening and maintaining a healthy community.
- **It reduces crime:** well maintained parks facilities help reduce crime in a community.
- **It promotes social bonds:** between individuals, families and communities building cultural tolerance.
- **It Unites families:** families that recreate together tend to be closer and more cohesive. By participating together family members elicit feeling of loyalty trust, harmony, team work and good will.
- **It builds cultural diversity and harmony:** the strength of a community is increased through recreation activities that allow people to share their cultural and ethnic difference, provides means for social interaction that can help to break down the barriers of unfamiliarity, fear and isolation.
- **It develops youth:** recreation assists in overall youth empowerment. it also help decision-making skills, cooperative behaviors, positive relationships and empowerment
- **It enhances education:** park lands and outdoor recreation facilities in country, city and state parks provide exceptional learning opportunities for students, directly impacting school performance
- **It deters negative behaviours:** recreation programs can provide safe, developmental opportunities for latch key children. The programs provide childcare in a stimulating setting, keeping children from being bored and keeping them out of trouble.

3 METHODOLOGY

Osogbo is the capital city of Osun state. Osun state was created on 27th August 1991, carved out from Old Oyo state. Traditionally, the people in Osogbo engaged in agriculture and produce, sufficient food for domestic consumption and as input for agro allied industry for export. Workers in Osogbo comprise mostly of civil servants, em-

ployees of private parastatals, and Bankers. Many residents of osogbo are into small and medium scale enterprises.

Osogbo being a state capital has number of recreational centers for public use. Among the highly patronized centers are: Delightsome hotel and park, Osun Osogbo Grove, GMT recreational park, Ripples fun center, Ideal nest, mercy tree pub, Osogbo sport stadium.

3.1 Method

The target population for this study is all middle class income workers in Osogbo metropolis. Middle class patronage to five recreation centers in Osogbo was selected as sample. These five recreation centers were purposively selected because they are highly patronized majorly by middle class income group. Data for this research work was collected using primary and secondary methods of data collection. A total of fifty respondents were sampled and questionnaire was used to solicit information from them using simple random technique.

Site observation: involves visiting recreational facilities in Osogbo (the study area) over a period of time to access and make systematic observations of the phenomenon.

The secondary data were collected from existing literature such as journal, textbook and academic magazine.

3.2 Research Instrument

The instrument used was questionnaire. The questionnaire had four main sections that collected information on: (1) Demographic characteristics of the respondents; (2) Major recreation facility that motivate the respondent; (3)How often the respondent engage in recreational activities; (4) Perception of influence of recreational activities on wellness of the respondents. The questionnaires were administered on weekend based on Knudson's (1984) opinion that recreational activities are mostly done on weekends, coupled with the fact that the population of this research is working class of the study area.-

Table 1: Distribution showing sampling procedure and size.

Recreation center	Questionnaire distributed	Question returned	Percentage of returned
Osun Osogbo grove	10	8	90.0
Delightsome hotel and park	10	9	90.0
Osogbo sport stadium	10	10	100.0
Mercy tree pub	10	10	100.0
GMT part	10	8	80.0
Total	50	45	90.00

Source: field survey, 2018

4 ANALYSIS, RESULT AND DISCUSSION

Data collected was presented using tables and graphs and described using frequency counts and percentages.

Table 2: Major facilities and Services of Recreational Centers

Recent Centers	Facilities
Delightsome Hotel and Park	Accommodation Swimming pool Mini zoo Game center Gymnasium
GMT Recreation Park	Accommodation Swimming pool Gymnasium Clubbing
Osogbo Sport Stadium	Indoor game Outdoor sport
Osogbo Grove	National scenery Vibrating bridge Osun river
Under the Mercy Tree Pub	Sales of Alcoholic beverages Sales of light meal Football Viewing center Live band entertainment

This indicates that the study area Osogbo has efficient firm recreational facilities for her residents

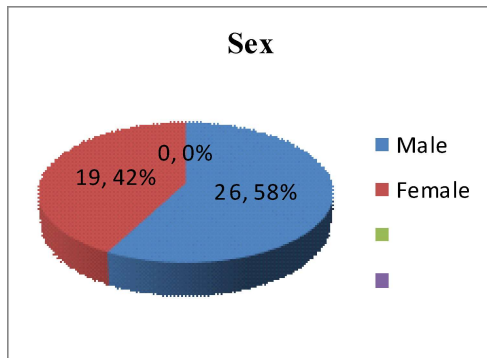

Figure 2: Distribution by Gender

The above chart shows that majority of middle class engaging in recreational activities are male (57.78%), while 42.22% of the respondent are female. This is an indication that more men engage in recreational activities than their female counterpart. The plausible reason for this could be that women have lesser leisure time than men, this is because the societal expectations of traditional role of a woman as a home maker tend to over burden them with dual and multiple responsibilities. This is consistent with the work of Delina and Raya, (2013), that confirmed that the ever increasing working pressure is taking a toll on women leaving them with less time for themselves or leisure.

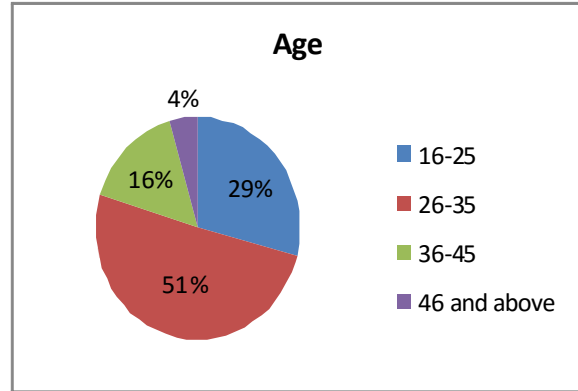

Figure 3: distribution based on age of the respondents

The chart above shows that 51.1% of the total respondents fell between age 26 and 35year, 28.89% fell between 16 and 25 years, while 4.44% of respondent are 46 years and above. The data revealed that a larger percentage was within age bracket of 26 and 35 years with 51.1% of total respondents. This implies that more youth participate in leisure activities.

Figure 4 reveals that 11.11% of the total respondents had at least secondary school certificate, 28.9% had ND/NCE; 53.33% had first degree, while only 6.9% had post graduate degree.

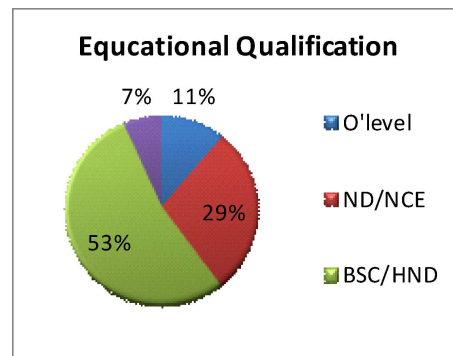

Figure 4: Distribution by Educational Qualification

Figure 5 shows that 64.44% of total respondent is single, 24.44% is married while 11.1% of total respondents is separated.

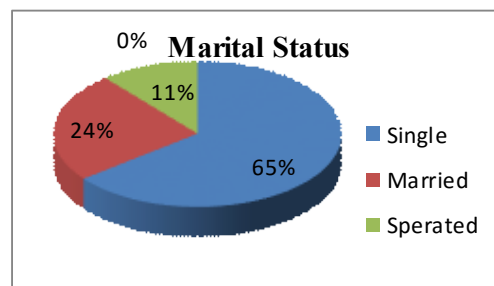

Figure 5: Distribution by Marital Status

This indicates that more singles utilize leisure and engage in recreational activities. This could be as a result of more free time because of absence of family commitment or work family conflict (WFC). In Figure 6, 13.33% of the respondents spends between 4 and 6 hours at work daily, 62.22% spends between 7 and 8 hour daily at work, while 24.44% spend more than 8 hours at work on daily basis.

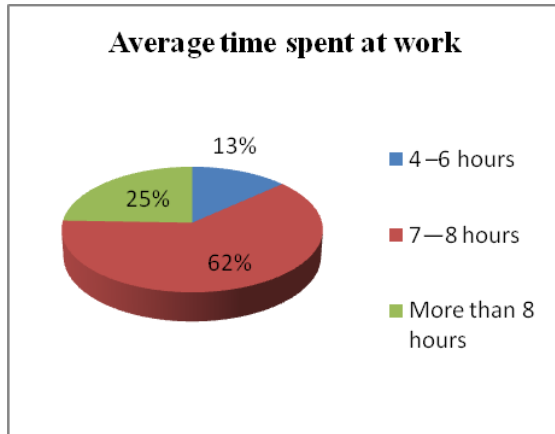

Figure 6: Distribution by Time spent at work

The above information implies that majority of the respondent spend normal working hours 7 to 8 hours at work, while 13.33% spend lesser hours . This indicates that there is ample time for leisure and recreational activities for middle class in Osogbo metropolis.

Figure 7 shows that 22.22% of the total respondents participated in gymnasium activities, 15.55 engaged in each in swimming, outdoor sports and football viewing. 13.33% visit pub. this implies that middle class in study area engages in active recreational activities.

Major Attraction that motivated the respondents.

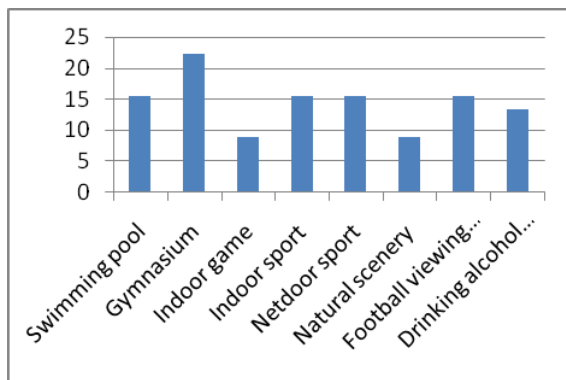

Figure 7: Distribution by Attractions that Motivates the Respondents

Figure 8 reveals that 62.22% of total respondents engages in recreational activities on weekly basis, followed by respondents that engage bi-weekly and bi-monthly at 15.55%

each, only 6.70% of total respondents participate monthly in recreational activities.

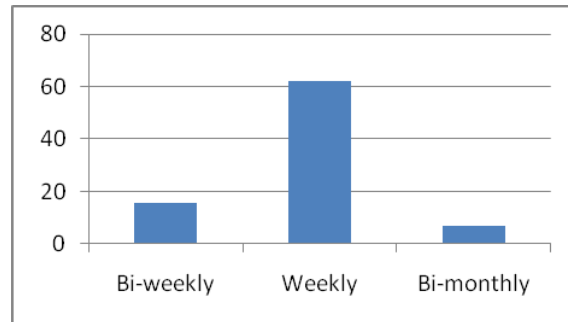

Figure 8: Distribution by how often respondents engage in recreational activities

This implies that middle class in Osogbo metropolis participate only on weekend in active recreational activities. This is consistency with the research of Knudson’s (1984), which confirmed that recreation activities are mostly done on weekends. From figure 9, majority of the respondents (48.9%) perceive mental health benefits from participating in recreational activities; 40% of total respondent enjoy physical health benefits, while 11.11% of the respondents receive social benefits from recreational activities participation.

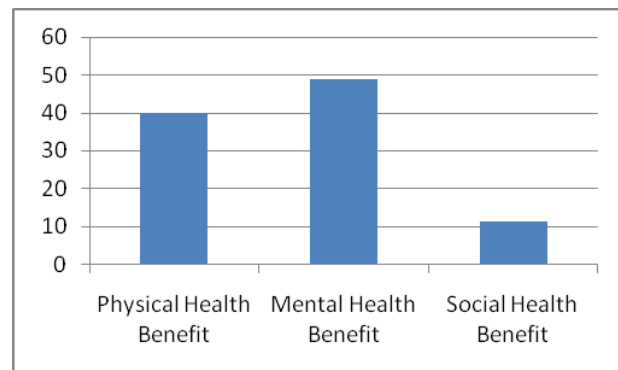

Figure 9: Distribution based on Perceived Benefits of Recreational Activities

Information in Figure 9 implies that engaging in recreation activities reduces depression, relieves stress and improve quality of lives of larger number of middles class in the study area.

4.2 Discussion

past researches show that stress is included with depression and anxiety as the second most common causes of occupational illness in statistics compiled by the United Kingdom Health and Safety Executive(HSE) causing the loss of 13.5 million employees in the working days of year 2007/2008 (Hall E.M. (1994); cited in Michie, 2002). It is also deduced from the findings of this work that pressure at workplace is unavoidable due to the demands of con-

temporary work environment; increasing demands on individual in the workplace reach out into homes and social lives of employees. Participating in recreational activities helps manage the pressure, provide self esteem and improve quality of life. Sedentary lifestyle can result in lot of health problems.

The study area, osogbo metropolis has number of recreation centers that can serve all ages and interests. However, more male of the middle class participates more in recreational activities than their female counterpart; more single than married and more youth than adult. Seventy five percent of total respondents spend 8 hours or less at work daily, which means middle class, have ample time as leisure to explore recreational centers.

The major attraction that motivated respondents and how often the respondents engage in leisure activities were also investigated. The study revealed that middle class in study area mostly engage in recreational activities weekly and the major attraction that motivated the respondents varied. When asked about benefits derived from participating in leisure activity, majority consented that mental health was highest benefit perceived, followed by physical health benefit and few identified social interaction as the benefit derived from recreational activities.

4.3 Conclusion and Recommendations

The study examined the influence of recreational activities on the wellness and level of participation among middle class income in Osogbo

Osogbo metropolis endowed with recreational resources that are of health, social and economic importance to the host communities. Briand, Sauve and Frechette, (2011), affirmed that recreation has a value for individuals and groups and also constitutes a means of improving the functioning of societies. The respondents expressed their willingness to visit recreation centers after work daily but for economic situating that do not avail them the spending towards leisure on daily basis.

This study thus recommends that government should put in place policies that will favors private investors in recreational business. The employers should ensure flexible working condition, so workers can enjoy their leisure. However, the employees should avoid overworking themselves, and spend leisure time for recreation activities only in order to enjoy the full benefits associated with it.

Acknowledgement

The author would like to thank the anonymous reviewers for their valuable comments.

REFERENCES

[1] Critcher C, Bramham P, Somlinson F. (2001). *Sociology of Leisure*. NEW YORK: Spoon press, an imprint of the Taylo'r and Francis Group; 2001

[2] Frank, M. A., & Gustafson, S. (2001). *The Reciprocal*

Influence of Self-esteem and Exercise. Retrieves from [http://www.behaviouralconsultants.com/exercise & self-esteem](http://www.behaviouralconsultants.com/exercise&self-esteem) in Nov. 6th, 2017.

[3] George Torkilsen (1986). *Leisure and Research Management*. 2nd edn London, E & F. N. Spon, p. 164.

[4] Gerofrey Godbey and Andrew Mowen (2010). *The Benefits of Physical Activity provided by Park and Recreation Services. The Scientific Evidence*. Natural Recreation and Park Association.

[5] Grant Cushman and Allan Laidller (1990). *Recreation Leisure and Social Policy*. Occasional Paper. No. 4, Canterburg, N2, Dept. of Parks, Recreation and Tourism, Lincoln University, P. 2.

[6] Hannel, R. G. & Lemire, F (2002). *Physical activity to prevent cardiovascular disease. How much enough? (Electronic Version)*. Canadian Family physical. 48, 65-71.

[7] Health Human Services, U. S. (HHS). (2001). *The Surgeon generals call to action to prevent and decrease overweight and obesity*. Rockville.

[8] Junhyoung Kim, Naoko Yamada and Areum Han (2014). *Health benefits of serious involvement in leisure activities among older Korean adults*. International journal of qualitative studies in health and well being. Kim et al July 23, 2014.

[9] Leisure eNewsletter, (2012). *Defined middle class as group in the society with income between approximately, one -third ($\frac{1}{3}$) below and two-third ($\frac{2}{3}$) above median income*.

[10] Louise Briand, Nathalie Sauve & Lucie Frechette, (2011). *The benefits and Economic value of community Recreation: Proposal for an Analytical Framework Based on Exploratory study: Canadian Journal of Nonprofit and social Economy Research*. ANSERJ, Vol. 2, No 1. p24-44.

[11] Nieman, D. C. (2001). *Does exercise Alter Immune Function and Respiratory Infections? Presidents Council for physical fitness & sport Research Digest*, 3(13).

[12] Oladeji S. O. and Adedapo O. O. (2014). *Performance and Visitor's Satisfaction of Recreation Facilities in Akure Metropolis: A Ventable tools for impact studies in UNDP Mdg's Cities in Nigeria*. British Journal of Economics, Management and Trade 4(8). Science Domain

[13] Osadare O. O. and Adeyemi M. O. (2017). *Leisure and Tourism Practice*. GLIA Publishing Company, Osogbo Nigeria. p.4.

[14] Randy White, (2012). *Trends in the middleclass entertainment spending*. Leisure eNews letter. White Hutchinson, Vol. X11, No. 2 february – March, 2012.

[15] SCRA (2005). *The health and social benefits of recreation: An element of the California outdoor recreation planning program*. CSP. Sacramento, CA.

[16] Siegenthaler, K. L. (1997). *Health benefits of leisure*.

park & Recreation magazine, 32(1) 25-27

- [17] Veal A. J. (1992). Definition of Leisure and Recreation. Australian Journal of Leisure and Recreation, 2(4), 44-48, 52. Republished by School of Leisure, Sport and Tourism, University of Technology, Sydney, as working Paper No. 4. accessed at www.business.uts.edu.au/1st/research on 5th of march, 2018.

SCIENCE AND BIOSCIENCE

Experimental Determination of Electrical Insulating Properties of Dry Coarse Sand and Dry Fine-Medium Sand in Comparison with those of MgO Powder by Ohm's Law Method

Markus N.Linah¹, Moses E.Kundwal^{2*}, Osita C. Meludu³ and Abati A. Alkasm³

¹Department of Basic and Applied sciences, College of Nursing and Midwifery, Yola, Nigeria

²Department of Physics, Federal College of Education, Yola, Nigeria

³Department of Physics, Modibbo Adama University of Technology, Yola, Nigeria

*mekundwal@gmail.com

Abstract— The objective of the study was to compare electrical insulating properties (electrical resistance, electric resistivity, electric conductivity, and current density) of dry coarse sand (0.50-1.00 mm); dry fine-medium sand (0.125-0.50 mm) and MgO powder. Ohm's law method was adopted and used to investigate electric insulating properties of the samples by allowing currents to flow through equal cylindrical length of 0.015 m and cross-sectional area of $1.131 \times 10^{-4} \text{ m}^2$ of the samples when potential differences of 100-300 volts were created across them. The two sand samples were sieved through sieves of apertures 2.00 mm, 1.00 mm, 0.50 mm, 0.25 mm, and 0.125 mm to obtain the required particle sizes for the experiment. Sample of MgO powder, an electrical insulator used in conventional electrical heating devices, was also obtained. Results showed that, the two dry sands possessed comparatively good electrical insulating properties and can serve as reliable and efficient alternative electric insulators in place of MgO powder in electric irons and kettles.

Keyword— Current Density, Electric Conductivity, Electric Intensity, Electrical Resistance, Electric Resistivity, Ohm's Law

1 INTRODUCTION

CONVENTIONAL electric irons and kettles are some of the most widely used house-hold electrical heating devices in Nigeria, especially in urban areas where electricity supplies are comparatively higher than in rural areas. Most of these heating devices are being imported from China and other developed countries of the world into Nigeria. As a developing country, Nigeria is still lagging behind in terms of industrial development for manufacturing of these basic electric heating devices. Many people in developing countries, including Nigeria, rely solely on the use of fuel wood for cooking and for boiling water leading to deforestation [1]. This calls for the need for scientists and engineers to close ranks and re-direct the nation's industrial sector towards the development and manufacturing of such electric heating devices that are affordable, efficient and reliable.

Thermal properties of dry coarse sand and dry fine-medium sand in comparison with those of MgO powder had been determined [2] and the result showed that dry sand possessed good thermal properties that could be harnessed in electrical heaters as electrical insulator in place of MgO powder. In addition, the time rate of heat transfer through both coarse sand and fine-medium sand at 0% moisture content is higher than through MgO powder [3]. However, thermal properties of these sands alone cannot justify their potential for use in the fabrication of electrical heating devices such as electric irons and kettles. Their electrical insulating properties are therefore as important as their thermal properties.

The objective of this study was to compare some electrical properties (electrical resistance, electric resistivity, electrical conductivity and current density) of dry coarse

sand, dry fine-medium sand and MgO powder, an insulator used in domestic electrical heating devices [4]. These electrical properties are the most important determinant of a material's potential to serve as electrical insulator in electric heating devices. Knowledge on electrical insulating properties of dry sands can also be applied on buried cables below the earth's surface at regions containing predominantly sandy soils and/or other soil types. In this case, the presence of soil moisture regimes beneath the earth and the possibility of ionic conduction due to the presence of ions in the soil solution is possible particularly where cable insulators are damaged [5].

The samples of dry coarse sand and dry fine-medium sand employed for use in this study were at 0% moisture contents to avoid errors resulting from electrolytic conduction associated with saturated soils. The mineral present in sandy soil is predominantly quartz. This mineral is an excellent electrical insulator. Also, the soil gas phase is mostly air which is a bad conductor of electricity and, like quartz, it opposes the flow of electric current [5]. Dry sands at 0% moisture contents, containing non conducting air and quartz can therefore be considered as reliable alternative electrical insulators in electric irons and kettles. In addition, the vast availability of sands on the surface horizon, in comparison with MgO powder, could render them to be the most preferred natural resource materials to be used as alternative electrical insulators in electric heating devices.

2 THEORETICAL

Electrical resistivity is a property which expresses its ability to oppose flow of electric charges. It depends on the

geometrical structure of the material and it is a factor that relates the distribution of electric field and the flow of electric charge in the material. It is given by Ohm's law as follows [5]:

$$E = \rho j \tag{1}$$

where E is the electric field intensity (i.e. potential gradient) and j is the current density (i.e. current per unit cross sectional area). Thus;

$$\text{Current density, } j = \frac{i}{A} \tag{2}$$

Consider a cylinder composed of uniform MgO powder or sandy soil material, having a length, L , and at each of its ends, a cross-sectional area, A (Figure 1). An electric current, I , defined as the flow rate of electric charge, is applied at one end of the cylinder and exits the other. The cylinder to a greater or lesser extent, opposes this through flow of electric current, thereby causing a drop in electric potential, ΔV , which occurs along the coulomb's length from the end where I enters to the end where I exits the cylinder.

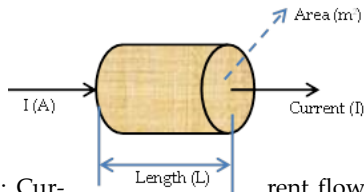

Figure 1: Current flow through a uniform cylindrical soil (adapted from [5]).

Electric potential can be described as the potential energy for a unit charge resulting from its position within an electric field. As indicated in Equation (3) below, ΔV is proportional to I , and the proportionality constant is the resistance, R , which is the characteristic of the cylinders overall ability to oppose current flow:

$$\Delta V = RI \text{ from which } R = \frac{V}{I} \tag{3}$$

The negative sign in Equation (3) simply indicates that current flow is in the direction opposite to that of increasing electric potential. Equation (3) is referred to as Ohm's law, and the resistance, R , of the cylinder can itself be expressed as:

$$R = \rho \frac{L}{A} \text{ from which } \rho = \frac{RA}{L} \tag{4}$$

where again, L and A , are the length and cross sectional area of the cylinder respectively, and ρ is the resistivity. Electric intensity is therefore given as:

$$\text{Electric intensity, } E = \frac{V}{L} \tag{5}$$

As stated earlier, resistivity is a property only of a

material composing the cylinder and represents the capability of that material to oppose the flow of electric current. The ρ values for soils and rock materials are typically reported in units of Ohm-meters (Ωm). Electrical conductivity, σ , is the reciprocal of ρ and is the property indicative of a material's ability to convey electrical current. It is also expressed as;

$$\text{Electrical conductivity, } \sigma = \frac{j}{E} \text{ or } \sigma = \frac{1}{\rho} \tag{6}$$

3 EXPERIMENTAL

3.1 Sample Preparation

To determine electrical insulating properties of dry coarse sand and dry fine-medium sand, sand sample of varying grain sizes was obtained within the bank of River Benue in Yola, Adamawa State, Nigeria. The sand sample was light brown, loose and granular without any bonding mechanism. It was also free from sandstones, scattered surface rocks and other soil types.

The size ranges of sand particles originally proposed by Glossop and Skepton in 1945 [6] was adopted in this study. These size ranges as defined in BS 5930:1981 and also U.S Department of Agricultural system is presented in the table below.

Table 1: Particle sizes of dry sandy soil

Class name	Particle size (mm)	Test procedure
Very coarse sand	1.0-2.0	Sieve analysis
Coarse sand	0.5-1.0	
Medium sand	0.25-0.5	
Fine sand	0.125-0.25	
Very fine sand	0.05-0.125	

(Adopted from [6])

Before the dry sand sample was sieved, aggregates and organic matter must be broken down and removed [6]. The sand sample was first air dried and sieved through a 2.00 mm sieve. Hydrogen peroxide (H_2O_2) was added to the sand, well stirred and left to stand overnight in a container of known weight. H_2O_2 was used to destroy the organic matter present in the sand [7]. The container and its content were placed on a hot plate for few minutes in order to destroy the remaining organic matter after which it was washed with distilled water. More H_2O_2 was added to ensure that all organic matter was removed. The container and its content were heated again to decompose any remaining peroxide in the sand. At this point, enough distilled water was added and well stirred, cooled and allow to stay over-night. The remaining organic matter that was seen floating on the surface of the water was removed carefully by decantation. The sand was sun dried for three consecutive days. After sun drying, the container and the sand were weighed. Subtracting the weight of the container from the total weight gave the weight of the sand free from organic matter. The sand was then ready for particle size analysis.

The sand sample was sieved through sieve sets of apertures 2.00 mm, 0.25 mm, 1.00 mm, 0.50 mm, and 0.125 mm. The initial mass of the sand sample used in this study

was 500 g. The sieves were arranged in descending order from the largest aperture to the smallest. The sand sample was released into the first sieve and the whole assembly was put in a mechanical shaker to shake for 5 minutes. Each of the samples retained in the sieve was weighed (weight retained). This was applicable to all sieves in the series. It was from this particle size analysis that dry coarse sand of particle sizes 0.50-1.00mm and dry fine-medium sand of particle sizes 0.125-0.50 mm were obtained.

MgO powder was also obtained. Few conventional electrical heaters were purchased and destroyed to get the sample. The powder was then packed in a closed container to avoid dust and other particulates from contaminating it.

3.2 Experimental Setup

Ohms law method was adopted in this study for use in the determination of electrical insulating properties of the sample materials. This was done by putting each of the three samples respectively in three identical tubes of same dimensions of length, cross-sectional area, thickness, and inner and outer diameters. Their electrical insulating properties (electrical resistivity, current density, electrical resistance and dielectric) were determined.

Figure 2 shows the circuit diagram for the experimental set-up. Equal volumes of the three samples were enclosed respectively in three identical cylindrical tubes and compacted to a denser state. Lead wires were connected at both ends of each of the tubes. The cross-sectional area and length of the samples in each of the tubes were $1.131 \times 10^{-4} \text{ m}^2$ and 0.015 m respectively. Each of the three samples was connected to circuit one after the other while a potential difference of 100-300 volts were connected across their respective terminals. Readings of currents and current densities were obtained and tabulated.

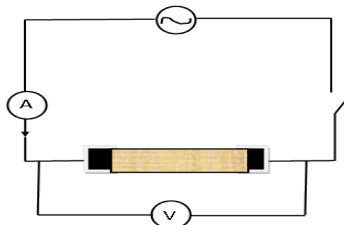

Figure 2: Circuit diagram for determination of electrical insulating properties of sampled materials

4 RESULTS AND DISCUSSION

4.1 Particle size distribution

Particle size distributions of sand affect both its thermal and electrical insulating properties. Thermal properties of sand increase with increase in its particle size and degree of compaction [8]. In order to draw up a particle size distribution curve, it was necessary to calculate the cumulative percentage by mass of particles finer than each sieve aperture size that was passing each sieve. Table 2 gives the results of the particle size analysis while the particle size distribution curve is shown in Figure 3.

Table 2: Results of particle size analysis of dry sand with initial mass $m=500\text{g}$.

Sieve size (mm)	Mass retaining (g)	Cumulative mass passing (g)	Percentage passing (%)
2.00	0	500	100
1.00	20	480	96
0.50	180	300	60
0.25	234	66	13.2
0.125	62	4	0.8

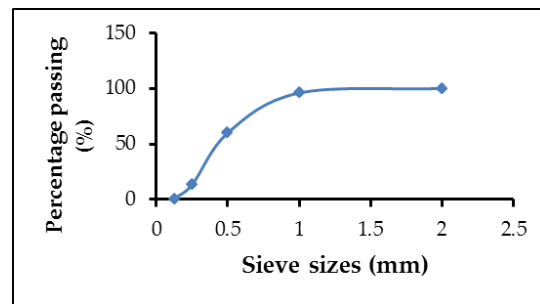

Figure 3: Percentage passing (%) against Sieve sizes (mm)

The interpretation of particle size analysis requires the drawing of a graph as in Figure 3. The shape and position of the graph provides qualitative information about the abundance of dry coarse sand and dry fine-medium sand samples required in the study. Thus, the analysis provides the basis for classification systems and their abundance in a given sample of soil. It was through this particle size analysis that dry coarse sand (0.50-1.00 mm) and dry fine-medium sand (0.125-0.50 mm) were obtained and used in this study.

4.2 Variations of Electrical Insulating Properties of the Sampled Materials with Potential Difference (p.d.)

Tables 3 shows the electrical insulating property data for the materials when potential differences of 100-300 V were created at the ends of their respective cylindrical lengths, While electric currents were obtained directly from ammeter reading at each potential drop, other values of electrical properties, example; resistances, resistivity, electric intensity and electric conductivity were calculated from Equations (3, 4, 5 and 6) respectively.

The electrical insulating properties of sands and of MgO powder were observed to vary with increase or decrease in potential difference generated across the ends of their cylindrical lengths. Data of electrical insulating properties of the materials presented here were used to study these variations. Graphs of potential differences against their corresponding values of electric current, electric intensity and current density of the sampled materials were plotted accordingly and are shown in Figures 4 and 5. Equations of trend lines of the various plots are displayed on the plot areas. The slope of regression of potential differences and measured values of currents for each of the three samples equals to their respective electrical resistances. Thus, using Equation 3, the resistances through MgO powder, dry coarse sand and dry fine-medium sand were found to be $3.835 \times 10^5 \Omega$, $3.835 \times 10^5 \Omega$ and 3.835

$\times 10^5 \Omega$ respectively.

Table 3: Electric current, electric intensity and current density data for the sample materials at p.d (100-300 V) across the length of 0.15m

p.d. (v)	$i_m (\times 10^{-6}A)$	$i_c (\times 10^{-6}A)$	$i_f (\times 10^{-6}A)$	$E (\times 10^2 Vm^{-1})$	$j_m (\times 10^{-2}Am^{-2})$	$j_c (\times 10^{-2}Am^{-2})$	$j_f (\times 10^{-2}Am^{-2})$
100	37.76	37.80	37.95	66.7	33.386	33.421	33.554
120	45.07	45.56	45.42	80.0	38.849	40.282	40.159
140	52.85	52.92	53.37	93.3	46.728	46.790	47.188
160	60.41	60.45	60.56	106.7	53.412	53.448	53.545
180	67.96	68.04	68.13	120.0	60.088	60.159	60.238
200	75.51	75.60	75.70	133.3	66.763	66.843	66.931
220	83.03	83.16	83.28	146.7	73.412	73.527	73.633
240	96.75	90.72	90.84	160.0	85.543	80.212	80.318
260	98.17	98.28	98.41	173.3	86.799	88.540	87.011
280	105.71	105.90	106.00	186.7	92.926	93.633	93.722
300	113.26	113.41	113.60	200.0	100.141	100.274	100.442

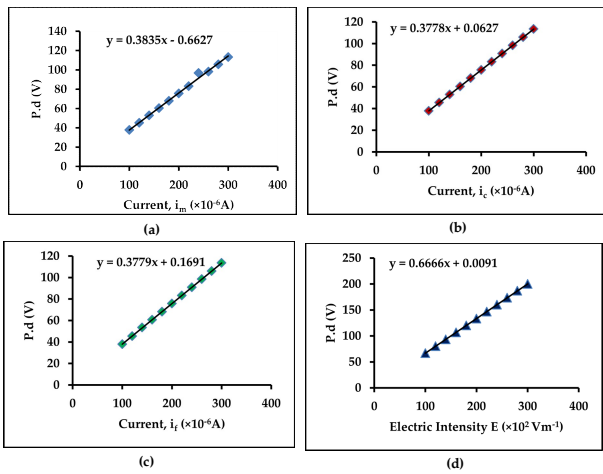

Figure 4: Variation of (a) potential difference with current through 0.015m length of MgO powder; (b) potential difference with current through 0.015m length of dry coarse sand; (c) potential difference with current through 0.015m length dry fine-medium sand; and (d) potential difference with electric field intensity across 0.015m lengths of the sample materials.

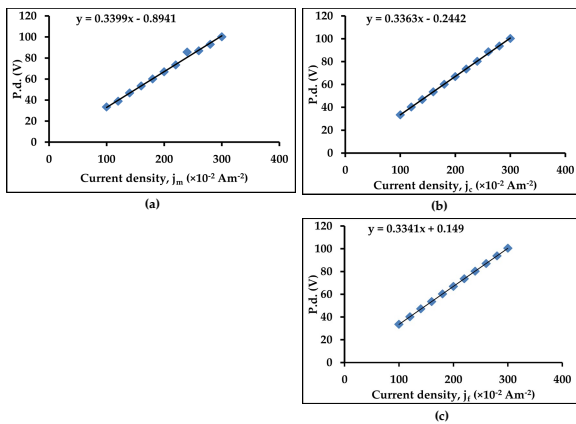

Figure 5: Variation of (a) potential difference with current density across 0.015m length of MgO powder; (b) potential difference with current density across 0.015m length of dry coarse sand; and (c) potential difference with current density across 0.015m length of dry fine-medium sand.

Employing Equation (5) and substituting the length 0.015 m, cross-sectional area $1.131 \times 10^{-4} m^2$ and the slopes, the electrical resistivity of each the samples were found, using the relation $\rho = \frac{P.d.}{I}$, where s is the respective slope of the graphs in Figure 5. With this relation, resistivity of MgO powder, dry coarse sand and dry fine-medium sand were found to be 2891.59 Ωm , 2840.612 Ωm and 2849.66 Ωm respectively. Since, electrical conductivity, σ , is the reciprocal of electrical resistivity, the electrical conductivities of MgO powder, dry coarse sand and dry fine-medium sand were also calculated (using Equation (6)) to be $3.50 \times 10^{-4} \Omega^{-1}m^{-1}$, $3.52 \times 10^{-4} \Omega^{-1}m^{-1}$ and $3.51 \times 10^{-4} \Omega^{-1}m^{-1}$ respectively.

The slope of the trend line for variations of electric intensities with potential differences across the sample materials was 66.7 m while the slopes of the trend line for variations of potential differences generated across the length of each of the sample materials and current densities was obtained in units of volts meter squared per ampere (Vm^2A^{-1}) to be $3.399 \times 10^5 Vm^2A^{-1}$ for MgO powder, $3.363 \times 10^5 Vm^2A^{-1}$ for dry coarse sand and $3.341 \times 10^5 Vm^2A^{-1}$ for dry fine-medium sand. It is evident from the foregoing that the electrical conductivities through the sample materials were very low due their high resistances. The electrical resistivities, on the other hand, were found to be greater in magnitude than those of electric conductors and semiconductors. For instance, silver which is the best conductor of electricity has a resistivity of $1.6 \times 10^{-8} \Omega^{-1}m^{-1}$ while silicon, a semiconductor material, has the highest resistivity of $2300 \Omega^{-1}m^{-1}$ than those of other semiconductors [9]. Thus, since resistivity of semiconductors falls immediately between those of conductors and insulators [9], it is clear from the results obtained in this study that dry coarse sand and dry fine-medium sand, whose resistivity values fall under insulators, possessed good electrical insulating properties with the potential for use as substitute to MgO powder in electrical irons and kettles.

It is important to note that the electrical resistance of a very dry human skin is 500 k Ω [10]. Hence, electric

currents in the order of microampere through the sand samples as presented in Table 3 are not high enough to cause muscular spasm due to this skin resistance. Therefore, kettles and electric irons made with dry coarse sand or dry fine-medium both at 0 % moisture content as electrical insulators are liable to be free from electrical shock.

5 CONCLUSION

In this study, we have shown that it is possible to substitute MgO powder used in these electrical house-hold heating devices with dry coarse sand and dry fine-medium sand at 0 % moisture content. Using Ohm's law method, the electrical resistance to flow of electric current through MgO powder of cylindrical length 0.015 m and cross-sectional area of $1.131 \times 10^{-4} \text{ m}^2$ was determined and found to be $3.835 \times 10^5 \Omega$ while the respective resistances to flow of current through same cylindrical length and cross-sectional area of dry coarse sand and dry fine-medium sand were $3.778 \times 10^5 \Omega$ and $3.779 \times 10^5 \Omega$ respectively. The percentage difference between the resistance in MgO powder and those of the two sand samples were approximately 1.5 % in each case. Using relevant formulae, the respective electrical resistivity and electrical conductivity of the samples were found to be **2891.59 Ωm and $3.50 \times 10^{-4} \Omega^{-1}\text{m}^{-1}$ for MgO powder;** 2840.612 Ωm and $3.52 \times 10^{-4} \Omega^{-1}\text{m}^{-1}$ for dry coarse sand and 2849.366 Ωm and $3.51 \times 10^{-4} \Omega^{-1}\text{m}^{-1}$ for dry fine-medium sand.

REFERENCES

[1] A. Pandey, V. V. Tyagi, A. L. S. Jeiraj, N. A. Rahim, and S. K. Tyagi, "Recent Advances in Solar Photovoltaic

Systems for Emerging Trends and Advanced Applications," *Renewable and Sustainable Energy Review*, vol. 53, pp. 859-884, 2016.

[2] M. N. Linah, O. C. Meludu, A. Alkasim, and K. E. Moses, "Determination of Thermal Properties of Dry Coarse Sand, Dry Fine-Medium Sand and MgO Powder using a Single Probe Method and Their Performance Evaluation in a Locally Fabricated Electrical Heating Device," *Nigerian Journal of Physics*, vol. 21, pp. 10-15, 2010.

[3] M. N. Linah, O. C. Meludu, and M. E. Kundwal, "Comparison of Heat Transfer Properties of Dry Sand and Magnesium Oxide Powder by Single-Probe Method," *Jurnal Teknologi*, vol. 77, pp. 93-97, 2015.

[4] F. Hall, *Plumbing and Heating (Third Edition)*: Macmillan press limited, London, 1980.

[5] J. Barry, J. J. Allred, and R. M. E. Daniels, *Hand Book of Agricultural Geophysics*: CRC Press, Taylor and Francis Group, London, 2008.

[6] R. H. Head, *Manual Laboratory Testing, Soil Classification and Compaction Test, Volume 1 (Second edition)*: 1992.

[7] L. D. Baver, W. H. Garder, and W. R. Garder, *Soil Physics (Fourth Edition)*: John Willy, New York, 1972.

[8] H. Nidal, R. Abu-Hamdey, and C. Reeder, "Soil Thermal Conductivity; Effects of Density, Moisture, Salt Concentration and Organic Matter," *American Journal of Soil Science Society*, vol. 64, pp. 1286-1290, 2000.

[9] T. Duncan, *Advanced Physics (Fourth Edition)*: John Murray (Publishers) limited, London, 1995.

[10] H. D. Young, *Sears & Zemansky's College Physics (Ninth Edition)*: Addison-Wesley, San Francisco, 2012.

Effects of Fungal Degraded Cob Product Supplementation on Broiler Chicks' Diet: Performance and Histopathological Characteristics

Bamigboye Olutoyin O.

Dept. of Microbiology, Adeleke University, Ede, Nigeria
toyinphd@gmail.com

Abstract—Agricultural waste which had been used in solid state fermentation for feed production include maize cob which has a large cellulose and hemicellulose reserve. Large scale fungal degradation of maize cob was carried out and the product, fungal degraded cob product (FDCP) was used to supplement broiler finisher diet at different concentrations. Significant differences were observed in the weight gain, feed efficiency and feed conversion ratio. The mean daily weight gain was higher in D2 birds (18% FDCP) the D1 (commercial feed) and other diets. The lungs and pancreas of all birds did not show any disease symptoms. However, the liver of birds fed diet 3 (50% FDCP) showed necrotic lesion while the kidney of diet 4 birds showed interstitial congestion and hemorrhage. It is concluded that low level of supplementation of FDCP up to 18% is advantageous to the bird.

Keyword—broiler diet; feed efficiency; fungal degradation; histopathology; maize cob,

1 INTRODUCTION

The unprecedented increase and prohibitive cost of conventional ingredients used in compounding live-stock feed has necessitated intensive investigations into the use of agricultural and agro-based industrial by-products (Adeyemi and Familade, 2003). Agricultural waste include maize cob, a major cereal by-product worldwide mostly prominent in Nigeria and their use as ruminants feed stuff has been reported (Alokan, 1988, Babayemiet *al.*, 2009., Jansen, 2012 and Kanengoriet *al.*, 2015). Maize cob is widely available in large quantity in Nigeria produced approximately 1.5million tonnes during the 2009 to 2010 season. It could be cheaply procured but it has the disadvantage of poor nutritional value (Dzowela, 1987, FAO, 2012, Jansen, 2012). Poultry, however, cannot access the nutrient in maize cob because their enzymatic digestion cannot properly breakdown the cellulose cell wall hence, the use of fermentation techniques (Dirar, 1992).

In agro-based industry, solid state fermentation has been applied in the process of transformation of food residues for the production of traditional fermented food, protein enrichment and single-cell protein production (updegraff 1971). The filamentous fungi are the best adapted microorganism for solid substrate fermentation owing to their physiological, enzymological and biochemical properties. Their ability to grow at low water activity and high osmotic pressure conditions makes fungi efficient and competitive in natural microflora, for bioconversion of solid substrate (Faniyi, 2006). Fermentation generally reduced crude fibre content in crop residues especially when fermented with fungi (Belawu, 2003) and increase

crude protein (Oduguwa, 2008).

However, the substantive effect of feeds compounded from such fermentation product on the chicken need to be determined. Onilude and Oso (1999b) reports that enzyme supplementation of various fibres had significant effect on the total lipid of the blood, liver and kidney of the birds relative to their age and type of fibre. However not much has been reported in the pathological effect of such feed supplement in major organs of the birds. This study therefore aims at investigating the effect of replacement of maize at different percentages with fungal degraded maize cob in the broiler diet, on the performance characteristic and the liver, pancreas, kidney and lungs of fed chicken.

2.0 MATERIALS AND METHOD

2.1 Organism and Cultural Conditions

The organism, *Aspergillusniger* utilized in this study was isolated from degrading maize cob. Isolation was made by using both pour plate and spread plate method of Olutiolaet *al.*, (1999). Pure culture of the bacteria was routinely maintained on potato dextrose agar slant.

2.2 Fermentation of Maize cob

2.2.1 Preparation of Inoculum for FDCP Production

Large quantities of maize cobs were sun dried to make them more friable for crushing by using laboratory hammermill. The crushed substrate was then sieved to get the required substrate size (1mm). Distilled water was added in ratio 1:2 substrate; water and chicken extract solution. Sterilization was done at 121°Cfor 15 minutes. On cooling, it was inoculated and left to ferment at 30°C for 28 days.

2.2.2 Scale up of Feed Production

Large scale production of FDCP was done by using a fabricated silo prepared from used cylindrical steel drum (60cm diameter and 110cm height). The inner portion of the silo was lined with 0.25mm polyethylene for each experimental bag in which fungal inoculum was used. Twenty four (24) kg of corn cob containing other additive was sterilized in a giant autoclave and loaded into polythene bag, inoculated with inoculum and then sealed up after which it was covered with metallic lid. Fermentation was allowed to take place for 28 days at room temperature. The product is the Fungal Degraded Cob Product.

2.3 Experimental Diets

Four dietary feeds containing basal diets were prepared in which FDCP was substituted for maize at 18, 50 and 82% while the commercial fed served as the control (Table 1). The experimental diets and clean drinking water were provided ad libitum throughout the experimental period. Conventional management practices were observed in all the seven treatments.

2.4 Experimental Birds

Four weeks old 40 broiler chicken (abroacha breed) were used in the study. They were individually weighed and randomly assigned to four treatments (diets) in groups of 10 birds per treatment. The treatments were replicated two times with 5 birds per replicate. The birds were maintained on the diets for six weeks.

2.5 Performance Characteristics

The feed intake, feed conversion ratio, feed efficiency, body weight and body weight gain of the experimental birds were determined on weekly basis for the period of six weeks. The daily feed intake was obtained by subtracting the left-over from the total amount of feed supplied. Birds in each group were weighed at the inception of the experiment and weekly thereafter to obtain the weekly and daily weight.

2.6 Histological Procedure

Histological processing (preparation of organs and tissues for macroscopic examination of the excised tissues of the lungs, liver, kidney and pancreas from the sacrificed broiler chicks of all the diets were performed using medical laboratory technology and clinical pathology (MLTCP) and MPAMA's procedure (Baker and Silvertens, 1985).

2.7 Analysis of Data

All the data obtained from the study were analyzed with SAS and SPSS, a computer software package to determine ANOVA and the test of significance were carried out using Duncan's multiple range tests (Dun-

can, 1955).

Table 1: Composition of the Experimental Diets (Broiler Finisher)

Ingredient %	Diets (Kg/100kg)			
	1	2	3	4
Maize	54.00	44.00	27.00	10.00
Fungal Degraded Cob	-	10.00	27.00	44.00
Product FDCP				
Wheat offal	10.00	10.00	10.00	10.00
Groundnut cake	15.20	15.20	15.20	15.20
Soybean meal	12.50	12.50	12.50	12.50
Fish meal	5.00	5.00	5.00	5.00
Bone meal	2.50	2.50	2.50	2.50
Broiler premix	0.30	0.30	0.30	0.30
Salt (Nacl)	0.30	0.30	0.30	0.30
Methionine	0.20	0.20	0.20	0.20
Total	100	100	100	100

3. RESULTS

The feed conversion ratio (FCR) for D4 was significantly higher (4.74) compared to 3.60, 2.97 and 3.96 found in D1, D2 and D3 respectively. Feed intake ranges from 4852g to 5190g in all the diets with the highest feed intake observed in D1 which is the commercial feed. Result of performance parameters are presented in Table 2. There were significant differences in the mean feed intake, body weight gain and mean daily weight gain of the experimental birds. The weight gained by D2 birds (18% FDCP) was higher (1635g) than in the control D1 (1440g) experimental D3 (1290g) and D4 (1058g). Feed utilizations was lowest in Diet 4 (82% FDCP) with the value of 0.21 compared to D1, D2, and D3 (0.28, 0.34 and 0.25) respectively. The histopathological examination of experimental birds revealed that no visible lesion in the pancreas in all diets (Table 3). The lungs showed mild congestion and generalized congestion in D1 and D2 birds respectively, no visible lesion was seen in lungs of D3 and D4 (Table 3). The liver also showed no visible lesion in D1, D2 and D4 and a few foci of necrosis in D3. However, the kidney of birds showed both interstitial congestion and haemorrhage.

Table 2; Performance of Broiler Chicken Fed Graded Levels of Fungal Degraded Cob Product FDCP

parameters	Treatment Diets			
	1	2	3	4
Initial Weight (g)	600 ^a	540 ^b	570 ^b	530 ^b
Final weight (g)	2046 ^a	2175 ^b	1860 ^c	1588 ^d
Weight gain (g)	1,440 ^b	1635 ^a	1290 ^c	1058 ^d
Mean daily weight gain (g)	34.28 ^b	38.93 ^a	30.71 ^c	25.19 ^d
Feed intake (g)	5190 ^a	4852 ^d	5105 ^b	5020 ^c
Mean daily feed intake (g)	123.57 ^a	115.52 ^d	121.54 ^b	119.52 ^c
Feed conversion Ratio (FCR)	.3.60 ^c	2.97 ^d	3.96 ^b	4.74 ^a
Feed Utilization (FU)	0.28 ^{ab}	0.34 ^a	0.25 ^{bc}	0.21 ^c

Table 3: Histopathological Studies of Experimental Birds Organs (fed FDCP)

Treatment/Diet	Liver	Kidney	Lungs	Pancreas
D1	No visible lesion seen	The interstitial (lymphoid) compartment is reduced in density	Very mild congestion	No visible lesion seen
D2	No visible lesion seen	Marked haemorrhage in the interstitium, few tubular cells are necrotic	Generalized congestion	No visible lesion seen
D3	There are few foci of necrosis and cellular infiltration by mononuclear cells	Mild congestion	No visible lesion seen	No visible lesion seen
D4	No visible lesion seen	Interstitial congestion and haemorrhage	No visible lesion seen	No visible lesion seen

4 DISCUSSION

Significant differences were observed in all the performance parameters of the experimental birds. The value of the feed conversion ratio in D4 (82% FDCP) was significantly higher than in other diets. This showed that high feed intake does not have a corresponding effect on weight gain. Aderoluet *al.*, (2007) also observed that feed conversion efficiency became poor with corresponding incremental level of fibre. This low productive value has been attributed to the possible presence of β – glucan in the added dietary fibres which could give rise to highly viscous conditions in the small intestine and interfere with nutrients absorption (Hesselman and Aman, 1986). The mean daily weight gain was higher in D2 birds (18% FDCP) than D1 (commercial feed and other diets), this showed that 18% FDCP substitution is beneficial to the birds. The improvement in weight could be attributed to the fact that the birds in the present investigation were able to adopt to the high dietary fiber-rich diet (Onilude and Oso, 1994), which has been partially degraded by the fungal isolate.

There was no significant difference in the feed utilization / efficiency in D1 D2 and D3. This showed that birds fed 18% and 50% were able to utilize their feed for maximum weight gain like the commercial feed. Adeyemi and Familade (2003) also observed that up to 20% fermented maize cob replacement of maize showed little difference in the observed weight gain of the chicken. The lungs and Pancreas of the birds in all the treatments did not show any major symptoms of disease condition. However the liver and kidneys of the birds fed Diets 3 and 4 were affected by the diet. These could be linked to the roles of these organs in the elimination of metabolic wastes and toxins from the body (Olajide, 2012). Hence these organs can easily be affected by the type of diet taken by the birds. The liver of birds fed Diet 3 showed a few foci of Necrotic lesion while the kidneys of the birds in Diets 2 and 4 showed haemorrhage in the interstitium and interstitial congestion and haemorrhages respectively. Kidney and liver are primary organ of biotransformation in animals (Onyeyili *et al.*, 1998) hence, the effect of the diet on these vital organ must be determined.

5. CONCLUSION

Results from this study indicated that maize could economically be replaced by 18% FDCP in the diet of broiler finisher without compromising the quality and quantity of carcass birds and without deleterious effect on the health status of the birds.

6. ACKNOWLEDGMENT

The author wishes to thank The Department of Microbiology, University of Ibadan for their support during the research.

7. REFERENCES

- [1] Aderolu, A.Z., Iyayi, E.A. and Onilude, A.A. (2007) Performance, organ relative weight, serum and haematology parameters in Broiler finisher fed biodegraded brewer dried grain. *Pakistan Journal of Nutrition* 6 (3) 204-208.
- [2] Adeyemi, O.A. and Familade, F.O. (2003). Replacement of Maize by rumen filterate fermented corn cob in layers diet. *Bioresource Technology*: 90: 221-224.
- [3] Alokun, J.A. (1988) A note on maize cob in sheep diet. *Nigeria Journal of Animal Production* 15: 227-323.
- [4] Babayemi, O.J., Otukoya, F.L., Familade, F.O. and Daodu M.O., (2009). Assessment of nutritive value of bovine liquor and urea-treated corn-straw and maize cob as feed for the west African dwarf sheep and goats. *Nigeria Journal of animal production* 36:213-224.
- [5] Belawu, M. A. (2003). Nutritional qualities of maize cob and waste paper incubated with edible mushroom. *Nigeria Journal of Animal Production*
- [6] Baker, F. J. and Silverton, R.E. (1985). Introduction to Medical Laboratory Technology, 6thed. Butenvort, England, 408pp.
- [7] Dirar, H.A. (1992) Traditional Fermentation Technology and Food Policy in Africa. *Appropriate Technology* 19(3) 21-23.
- [8] Duncan, D.B. (1955) Multiple range and multiple F-test. *Biometrics* 11, 1-4.
- [9] Dzowela, B.H. (1987). Effort to enhance maize stover utilization for small holders livestock producer in Malawi. In proceedings of ARNAB workshop on the utilization of Agricultural By-product as Livestock feeds in Africa. Pp 27-36.
- [10] FAO, (2012). FAOSTAT Crop production. FAOSTAT, FAO statistics Division, 2012 <http://faostat.fao.org/site/567/desktopdefault.aspxancor>.
- [11] Hesselmen, K.I and Aman, P. (1986). The effect of β -glucanase on the utilization of starch and nitrogen by broiler chicken fed on barley of low or high viscosity. *Animal feed science and Technology* 15, 83-93.
- [12] Jansen, C., (2012). Breeding for cob traits in maize. In Iowa state Univ., Grad. Thes. Dissert, Paper 12982. <http://www.feedipedia.org/node/718>.
- [13] Retrieved on 3rd April, 2018.
- [14] Kanengori, A.T., Chimonyo, M., Ndimba, B.K and Dzama, K. (2015). Potential of using maize cobs in Pig Diets-A Review. *Asian-Australasian Journal of Animal Science* (12) 1669-1679.
- [15] Oduguwa, O.O.,Ederna, M.O. and Ayeni A.O. (2003). Physicochemical and microbiological analysis of fermented maize cob, ace bran and cowpea husk for use in composite rabbit feed. *Bio Resource technology* 99: 1816 – 1820.
- [16] Olutiola, P. O., Famurewa, O. and Sonntag, I.G. (1991). An Introduction to general microbiology. A practical approach. Hendlberger Yerlagsanstalt and Druckerci G MbuHendlbergPp 267.
- [17] Onilude, A,A,. (1999). Fermented poultry litter and fungal enzyme supplementation of high fibre broiler diets; growth responses, carcass characteristics and blood lipid of fed chicks. *Nahrung* 43: 54-60.
- [18] Onilude,A.A., and Oso,B.A. (1999). Effect of Fungi Enzyme mixture supplementation of various fibre – containing diets feed to broiler chicks 2: On blood, liver and kidney total lipids, triancylglycerols and cholesterol. *World journal of microbiology and biotechnology* 31 (2) 51-56
- [19] Oniyelli, P. A. Iwuoha C.I. and Akinniyi, J.A. (1998). Chronic toxicity study of FicusPlatyphyllablume in rats *West Africa Journal of Pharmacol Drug. Res.* 14: 27-30.
- [20] Updegaff, D.M. (1971). Utilization of cellulose from waste paper by Myrotheciumverucaria. *Biotechnology and Bioengineering* (1) pp 77-79.

Production and Moisture Content Optimization of Cellulase and Xylanase by Newly Isolated *Rhizopus oryzae*UC2 using Raw Oil Palm Frond Leaves as Substrate in Solid State Fermentation

Uchenna R. Ezeilo^{1,2} and Roswanira Abd. Wahab³

¹Department of Biotechnology, Faculty of Bioscience and Medical Engineering, Universiti Teknologi Malaysia

²Department of Chemistry/Biochemistry, Faculty of Science and Technology, Federal University Ndufu-Alike Ikwo, Ebonyi State, Nigeria

³ Faculty of Science, Universiti Teknologi Malaysia

[*ucmgbenka@gmail.com](mailto:ucmgbenka@gmail.com)

Abstract—Oil palm frond (OPF) is the most abundant waste biomass produced in major oil palm producing countries such as Malaysia. By virtue of being a lignocellulosic biomass, contains cellulose and hemicellulose that stimulate the production of cellulase and xylanase enzymes by certain fungi. Moisture content, being one of the major factors affecting fungal growth and enzyme production in solid state fermentation (SSF), was optimized using the newly isolated cellulolytic and xylanolytic zygomycetes strain- *Rhizopus oryzae*UC2 and raw oil palm frond leaves (OPFL) as growth substrate. Maximum cellulase and xylanase activities were recorded at optimum moisture content of 40 % (v/w). Under SSF conditions of using dried and grinded raw oil palm frond leaves of size 1-3 mm as growth substrate, moisture content (40 %), initial pH (5.2), temperature (30° C) and inoculum size of 2.0×10^8 Spores/g, the activities of CMCase (endoglucanase), FPase (exoglucanase), β -glucosidase and xylanase reached their maximum of 112 U/g, 13 U/g, 145 U/g and 205 U/g respectively, all on the 5th day except β -glucosidase which was on the 6th day. These results show that relatively, low moisture SSF conditions are suitable for efficient cellulase and xylanase production by *R.oryzae* using OPFL as growth substrate.

Keyword— Moisture content optimization; oil palm frond; fungal enzymes; solid state fermentation; lignocellulosic biomass

1 INTRODUCTION

The lignocellulosic biomass constitutes the most abundant renewable biopolymer on earth, having cellulose, hemicellulose, lignin and in some cases pectin as the major components. A large share of this waste biomass is produced as post-harvest plant biomass by the agro-industry. In the palm oil mill, palm oil makes up only 10% of the total biomass. The rest, 90% biomass are discarded as wastes [95]. During oil palm fruit harvesting the pruning of oil palm frond (OPF) produces approximately 44 million tonnes dry weight of OPF annually. In 2012, an estimated 83 million tonnes (dry weight) of oil palm biomass wastes were available throughout the country [96], [97]. It is projected that these wastes will keep increasing, up to 100 million tonnes dry weight by 2020 [98]. Globally, over 190 million tonnes of solid and liquid residues are generated from the palm oil industries [99].

In 2009, it was recorded that about 77.3 million tonnes of oil palm biomass wastes was generated by the Malaysian oil palm industry [100]. The different types of oil palm biomass (OPB) waste generated and their respective quantities based on relative percentage dry weight is as follows;

oil palm fronds contributed the highest- 44.8 million tonnes (57.96%), making it the largest biomass source in the oil palm industry [101], trunk forms the second largest -13.97 (17.98%) million tonnes followed by fibres and shells (15.01%) and empty fruit bunch (9.06%). These excess OPB are left in the plantations, some of which are used for nutrient replacement or mulching purposes [97], while most of them lie in waste and left to decompose naturally. This process takes a considerable length of time due to the recalcitrance of the lignocellulosic contents. OPF which translates to OPFL are available throughout the year, when the palms are pruned or during the fruit harvest [102]. There are high potentials for the biomass waste to be converted to value-added products such as enzymes, biofuel, compost, among others, thus could generate income for the nation.

Bacteria and fungi has the ability to degrade amorphous cellulose component of lignocellulosic biomass, rapidly and efficiently [103], but the ability to degrade crystalline cellulose is restricted to very specialized cellulose degrading microorganisms [104].

Fungi are the best lignocellulosic degraders and among microorganisms, they are of great significance in

enzyme production as they secrete their enzymes extracellularly [105]. They belong to soft rot fungi (Ascomycetes, Zygomycetes) and brown or white rot fungi (Basidiomycetes) groups. Each group produces a collection of enzymes dedicated to the degradation of a specific plant polysaccharide; including many families of glycoside hydrolases, esterases, and lyases. Many of these families are characterized by multiple catalytic activities, many of which show complementary activity over the same substrates [106], [107]. *R. oryzae* is a soft rot Zygomycetes which have been used in previous works in food fermentation and enhancement of food tastes [108], production of ethanol and organic acids such as lactic acid, succinic acid etc [109]–[111], but, none has assessed its use for the production of cellulolytic and xylanolytic enzymes using raw oil palm frond leaves as growth substrates.

SSF is generally defined as the growth of microorganisms on solid material in the absence or near absence of free water [112]. It has been well established from previous studies that enzymes produced in SSF systems are several folds higher than in submerged fermentation (SmF) systems [113]. Enzyme production through SSF has advantages such as process is simple, it is cost effective, high concentration of products, reduced energy requirement, less effluent released thus reduces pollution, aeration process is easier, resembles the natural habitat of some fungi and bacteria and easier downstream processing [114].

In line with the basic requirement for all living creatures, fungi require three essential components to sustain life, which includes air (for aerobic fungi), water and nutrition (food). Most fungi are aerobes and digest a vast array of organic matter. The availability of water is one of the major factors that can be controlled to either prevent or enhance fungal growth and involved in primary metabolic processes such as secretion of enzymes, sustained enzyme activity and subsequent breakdown of complex substances, dissolution and absorption of nutrient solutes as well as in secondary metabolic processes. A certain level of “free” water (moisture) which is unique to various fungi is required for fungal growth to occur. Free means not bound to other molecules or to the cell wall. Cellulolytic and enzyme production depends greatly on the moisture to substrate ratio and the moisture requirement varies with microorganisms and type of substrate. In light of this, moisture content is therefore an essential SSF parameter and has become imperative to optimize the culture conditions for this newly isolated *R.oryzae*UC2 towards the enhancement of cellulase and xylanase productions forming the main focus of this study.

2 MATERIALS AND METHODS

2.1. Materials

All chemicals used in this work were produced by Sigma-Aldrich, USA and EMD Chemicals Germany. The

fungal strain used was isolated from decaying OPEFB and molecularly identified as *Rhizopus oryzae*UC2.

2.2. Preparation of Inoculum

The inoculum was prepared by maintaining the fungus on PDA plates at 30°C for 7 days. *R.oryzae*UC2 spores were harvested according to the method of Ang et al. 2013.

The spores were then diluted to obtain the spore inoculum of 2.0×10^8 spores/g of ground OPFL.

2.3. Production of Cellulolytic and Xylanolytic Enzymes and Optimization of Moisture Content in Solid-State Fermentation

The OPFL was ground into smaller particle sizes using a table blender (NL9206AD-4, Philips UK); particles size of 1-3 mm. The solid-state fermentation (SSF) was prepared by moistening the sieved OPFL with appropriate volumes of the production medium and spore suspension of *R.oryzae*UC2 (2.0×10^8 spores/g of OPFL) until final moisture levels of 40 %, 60 %, 70 %, 80 %, 90 % was achieved. The final moisture levels of the OPFL substrates were determined using a moisture analyser (MX50, A&D Weighing Co., Ltd., Japan). The flasks containing the OPFL substrates plus the production medium were autoclaved at 121 °C and 20 psi for 20 mins followed by inoculation with the fungal spores. The production medium consisted of a modified Mendel medium [115] with adjustments made with the increase in yeast 1.25g/L, peptone 1.0 g/L and 2mL of Tween 80. Production media set at an initial pH 5.0 using 1M NaOH and 1M HCl. All inoculated flasks were incubated at 30 °C for 7 days and 4 g of the fermented OPFL substrates were drawn every 24 h intervals for cellulases and xylanase analysis.

2.4. Extraction of Crude Enzymes and Analysis of Cellulase and Xylanase Activities

Fermented substrate of approximately 2 g was transferred into a 250 mL Erlenmeyer flask containing 50 mL of cold 0.05M sodium acetate buffer. The suspension was vortexed at maximum speed for 1 min to extract the cellulases and xylanase enzymes. The mixture was centrifuged at 4000 rpm for 20 min and the supernatant used as crude enzymes source was decanted. The crude enzyme cocktails containing cellulases and xylanase were stored at -20°C prior to assay to prevent enzyme degradation. The EnG, ExGI and BGL activities were considered to represent the cellulase activity of the crude enzyme. A glucose calibration curve was used to estimate the (carboxymethylcellulase, CMCase), and ExG (filter paper, FPase) activities, a *p*-nitrophenol (*p*NP) calibration curve was used to estimate the β GL activity while a xylose calibration curve was used to estimate xylanase activity. All calibration curves were determined using a set of triplicate preparations to minimize error in the respective assays. The enzyme activities were assayed in triplicates and the activity of each type of

enzyme was estimated based on standard procedure recommended by IUPAC [116]. Xylanase activity was assayed under the same conditions as above except birchwood xylan 1% (w/v) was used as the substrate [117]. One unit of exoglucanase activity is expressed as 1 μ mole of glucose liberated per ml of enzymes per minute and one unit of xylanase activity is expressed as 1 μ mole of xylose liberated per ml of enzyme per minute. All reaction mixtures above were boiled for 5 mins with 1 mL 3,5-dinitrosalicylic acid (DNS) solution and 2 drops of 0.1 M sodium hydroxide to estimate the reducing sugars released [118]. BGL production was done according to a modified method of Takashima *et al.*, 2007 [119]. One unit of β -glucosidase activity is expressed as 1 μ mole of *p*-nitrophenol liberated per ml of enzyme, per minute.

3 RESULTS AND DISCUSSION

Filamentous fungi play invaluable role in the earth's carbon cycle. This fit is made possible by the groups of hydrolytic and oxidative enzymes they produce that drives the recycling of carbon through efficient decomposition of plant cell wall materials.

Our results showed that enzyme activity was influenced by moisture content variation which is unique to the fungal species and nature of substrate used. This affects both fungal growth and secondary metabolism [120]. The production of cellulases and xylanase by *R. oryzae*UC2 in SSF for 7 days using OPFL as growth substrates, at 2.0×10^8 spores/g inoculum size and at initial pH of 5.2 was tested in moisture content ranging from 40 – 90 %. 40 % moisture content was best suited for the production of CMCCase (Figure 3.1), FPase, β -glucosidase and xylanase revealing yields of 112.13 ± 0.10 U/g, 13.0 ± 0.29 U/g, 145.47 ± 0.32 U/g and 205.05 ± 0.14 U/g respectively. These highest activities were all recorded on the 5th day except β -glucosidase which was on the 6th day. A similar result of SSF moisture content optimization was reported by Battaglino *et al* 1991 using *Aspergillus oryzae*. The substrates with high moisture may have presented an impediment to oxygen transfer that consequently constituted an adverse environment for fungal growth and enzyme production.

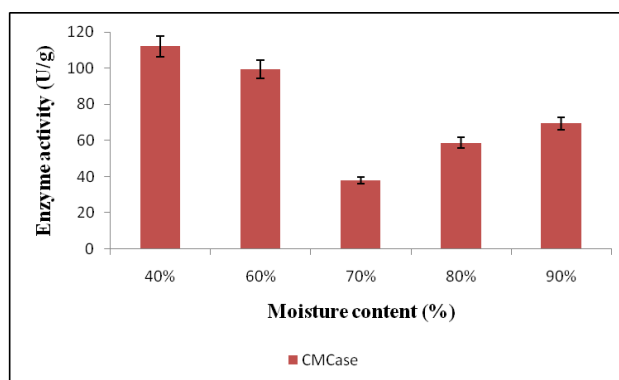

Figure 3.1 Highest CMCCase activities on different moisture content (%)

B-glucosidase is the cellulase enzyme that acts directly on the dimeric glucose molecule cellobiose, converting it to monomeric glucose units. In this study B-glucosidase recorded the highest activity among the cellulase enzymes which may imply that *R.oryzae*UC2 is a cellobiose-utilizing fungi [121], [122] which can promote saccharification.

Being the first report on the use of OPFL as growth substrate using *R.oryzae*UC2, we have limited works to compare with since the effect of moisture variations in enzyme production not only vary with microorganism used but also to a large extent the nature of substrate used.

4 CONCLUSION

From the results of the study we conclude that for the production of cellulase and xylanase enzymes using *R.oryzae*UC2 in SSF, a moisture content of 40 % is the optimum and that raw OPFL is a promising growth substrate for the enzymes production. Future works include investigation of other SSF parameters, biochemical characterization of the enzymes, optimization using Response Surface Methodology (RSM) and assessment of degradation/saccharification of OPFL.

5 ACKNOWLEDGMENTS

The authors would like to acknowledge valuable help and suggestions provided by their colleagues.

6 REFERENCES

- [1] A. M. Al-Sadi, F. A. Al-Oweisi, S. G. Edwards, H. Al-Nadabi, and A. M. Al-Fahdi, "Genetic analysis reveals diversity and genetic relationship among *Trichoderma* isolates from potting media, cultivated soil and uncultivated soil," *BMC Microbiol.*, vol. 15, no. 1, p. 147, 2015.
- [2] AIM (Agensi Inovasi Malaysia), "National Biomass Strategy 2020: New wealth creation for Malaysia's biomass industry," vol. Version 2., 2015.

- [3] M. F. Awalludin, O. Sulaiman, R. Hashim, and W. N. A. W. Nadhari, "An overview of the oil palm industry in Malaysia and its waste utilization through thermochemical conversion, specifically via liquefaction," *Renew. Sustain. Energy Rev.*, vol. 50, pp. 1469–1484, 2015.
- [4] M. S. Umar, P. Jennings, and T. Urme, "Strengthening the palm oil biomass Renewable Energy industry in Malaysia," *Renew. Energy*, vol. 60, pp. 107–115, Dec. 2013.
- [5] C. O. Keat and T. Lee, "Sustainable utilization of oil palm wastes for bioactive phytochemicals for the benefit of the oil palm and nutraceutical industries," pp. 173–190, 2013.
- [6] W. Pei Qin Ng, H. Loong Lam, F. Yuen Ng, M. Kamal, and J. Heng Ee Lim, "Waste-to-wealth: green potential from palm biomass in Malaysia," 2012.
- [7] A. A. I. Luthfi, S. F. A. Manaf, R. M. Illias, S. Harun, A. W. Mohammad, and J. M. Jahim, "Biotechnological route for sustainable succinate production utilizing oil palm frond and kenaf as potential carbon sources," *Appl. Microbiol. Biotechnol.*, vol. 101, no. 8, pp. 3055–3075, Apr. 2017.
- [8] O. A. Hassan, M. Ishida, and I. M. Shukri, Oil-palm fronds as a roughage feed source for ruminants in Malaysia. Taipei City : FFTC, 1996.
- [9] L. R. Lynd, P. J. Weimer, W. H. Van Zyl, and I. S. Pretorius, "ERRATUM Microbial Cellulose Utilization: Fundamentals and Biotechnology," *Microbiol. Mol. Biol. Rev.*, vol. 66, no. 3, pp. 739–506, 2002.
- [10] J. Strakowska, L. Błaszczuk, and J. Chełkowski, "The significance of cellulolytic enzymes produced by *Trichoderma* in opportunistic lifestyle of this fungus," *J. Basic Microbiol.*, vol. 54, no. S1, pp. S2–S13, Jul. 2014.
- [11] S. Muthukrishnan, "Optimization and Production of Industrial Important Cellulase Enzyme from *Penicillium citrinum* in Western Ghats of Sathuragiri Hills Soil Sample Isolate," *Univers. J. Microbiol. Res.*, vol. 5, no. 1, pp. 7–16, 2017.
- [12] B. L. Cantarel, P. M. Coutinho, C. Rancurel, T. Bernard, V. Lombard, and B. Henrissat, "The Carbohydrate-Active EnZymes database (CAZY): an expert resource for Glycogenomics," *Nucleic Acids Res.*, vol. 37, no. Database, pp. D233–D238, Jan. 2009.
- [13] M. Couturier *et al.*, "Post-genomic analyses of fungal lignocellulosic biomass degradation reveal the unexpected potential of the plant pathogen *Ustilago maydis*," *BMC Genomics*, vol. 13, p. 57, 2012.
- [14] I. Cantabrana, R. Perise, and I. Hernández, "Uses of *Rhizopus oryzae* in the kitchen," *Int. J. Gastron. Food Sci.*, vol. 2, no. 2, pp. 103–111, Jan. 2015.
- [15] L. Zhang, X. Li, Q. Yong, S.-T. Yang, J. Ouyang, and S. Yu, "Impacts of lignocellulose-derived inhibitors on l-lactic acid fermentation by *Rhizopus oryzae*," *Bioresour. Technol.*, vol. 203, pp. 173–180, Mar. 2016.
- [16] A. Naude and W. Nicol, "Fumaric acid fermentation with immobilised *Rhizopus oryzae*: Quantifying time-dependent variations in catabolic flux," *Process Biochem.*, vol. 56, pp. 8–20, May 2017.
- [17] X. Wu *et al.*, "Production of Fumaric Acid by Bioconversion of Corncob Hydrolytes Using an Improved *Rhizopus oryzae* Strain," *Appl. Biochem. Biotechnol.*, vol. 184, no. 2, pp. 553–569, Feb. 2018.
- [18] R. Koyani, K. R. B. & Biotechniques, and undefined 2015, "Solid state fermentation: comprehensive tool for utilization of lignocellulosic through biotechnology," *J. Bioprocess. Biotech.*, vol. 5, p. 10, 2015.
- [19] G. Brahmachari, *Biotechnology of microbial enzymes : production, biocatalysis and industrial applications*. Academic Press, 2016.
- [20] N. Abu Yazid, R. Barrena, D. Komilis, and A. Sánchez, "Solid-State Fermentation as a Novel Paradigm for Organic Waste Valorization: A Review," *Sustainability*, vol. 9, no. 2, p. 224, Feb. 2017.
- [21] M. Mandels and J. Weber, "The Production of Cellulases," 1969, pp. 391–414.
- [22] T. K. Ghose, "INTERNATIONAL UNION OF PURE AND APPLIED CHEMISTRY APPLIED CHEMISTRY DIVISION COMMISSION ON BIOTECHNOLOGY* MEASUREMENT OF CELLULASE ACTIVITIES," *Pure Appl. Chem.*, vol. 59, no. 2, pp. 257–268, 1987.
- [23] T. K. Ghose and V. S. Bisaria, "MEASUREMENT OF HEMICELLULASE ACTIVITIES PART 1: XYLANASES," *Pure & Appl. Chem.*, vol. 59, no. 12, pp. 1739–1752, 1987.
- [24] G. L. Miller, R. Blum, W. E. Glennon, and A. L. Burton, "Measurement of carboxymethylcellulase activity," *Anal. Biochem.*, vol. 1, no. 2, pp. 127–132, Sep. 1960.
- [25] S. Takashima, A. Nakamura, and M. Hidaka, "Molecular cloning and expression of the novel fungal β -glucosidase genes from *Humicola grisea* and *Trichoderma reesei*," *J. Biochem.*, vol. 125, pp. 728–736, 1999.
- [26] X. Xu, M. Lin, Q. Zang, and S. Shi, "Solid state bioconversion of lignocellulosic residues by *Inonotus obliquus* for production of cellulolytic enzymes and saccharification," *Bioresour. Technol.*, vol. 247, pp. 88–95, Jan. 2018.



Tosteven Studios
a perfect touch for a living memory...

ARROWS
Transactions



978-978-55535-2-9

